

# TETRA Band selective repeater

## Off-air



### Features

- High and Medium power versions • Compact size
- High linearity • Robust design • Remote and local control as well as monitoring • Low power consumption
- Easy installation

### Description

The Off-air repeater provides TETRA coverage in confined areas via the two RF-connectors. One RF-connector is connected to an antenna pointing towards a TBS (TETRA Base station). The second RF-connector is connected to an indoor antenna, radiation cable or both combined. The repeater can be installed as a single repeater system or in a larger system comprising of several TETRA repeaters.

In the basic version the repeater can be monitored locally using RSE (Repeater executive software). Alarms can be monitored remotely via an external alarm system on site or via a GSM/UMTS network.

Should the operator of a TETRA network desire to have in-depth remote control and monitoring functionality, the repeater can be equipped with MCB (Master control board). The repeater can then be reached via TCP/IP over Ethernet, GSM/UMTS or TETRA using SAMS (Supervision and monitoring software). The management system has a built-in homepage and offers the possibility to control a variety of internal as well as external parameters, analogue and digital signals and alarms.

The management system will also monitor forward and reverse RF-power from and to the antenna. The repeater's software can be updated remotely via the management system.

The repeater can be supplied with Radiosystem's battery backup.

For easy installation the repeater is delivered with illustrative installation software.

### Specification

#### Electrical

Frequency band	380–430 MHz	
Bandwidth	5 MHz	
Pass band ripple	< +/- 1,5 dB	
Delay	Typical < 1µs	
Down link power per carrier	Medium power version 19 dBm @ 2 carriers	High power version 29 dBm @ 2 carriers
Up link power per carrier	19 dBm @ 2 carriers	19 dBm @ 2 carriers
Spurious and harmonics	< -36 dBm	
Gain	85 dB	
Gain adjustment	30 dB in 1 dB step	
In/output return loss	> 12 dB	
Impedance	50Ω	
Noise figure	< 4 dB	
Uplink AGC	40 dB	
Power supply	90–260 V, 47–63 Hz	
Power consumption	Medium power version < 35W	High power version < 140W

#### Mechanical

	Wall mount	19" Mount
Dimensions	400 x 500 x 250 mm	400 x 440 x 350 mm
Weight	< 30 kg	< 30 kg
Protection class	IP54	IP20
Operating temperature	-10 to +55°C	
RF connectors	N-female	
PC connector	RS232 and Ethernet	
GSM-antenna connector	TNC-female	
Alarm output	NO and NC (3 pol mini-DIN)	

Radiosystem's Best Practice Continual Improvement Program means this data may be subject to alteration.

# TETRA Band selective repeater Off-air

## Block diagram

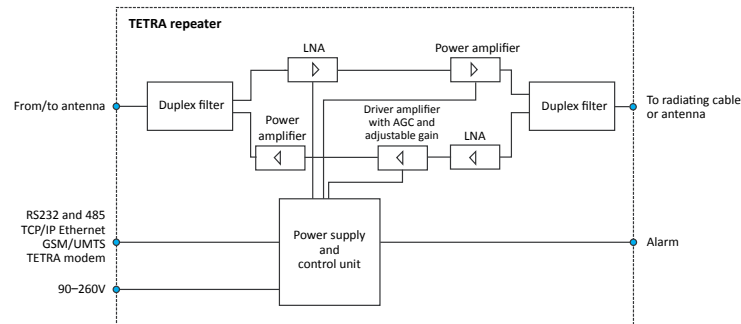

## Typical TETRA system Off-air

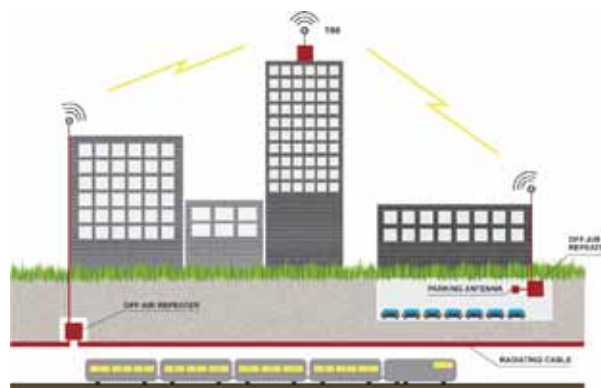

## Ordering information

Article	Type	Description
271008	BSROM	Band selective off-air repeater, medium power, wall mount
271010	BSROH	Band selective off-air repeater, high power, wall mount
271009	BSROMR	Band selective off-air repeater, medium power, 19" mount
271011	BSROHR	Band selective off-air repeater, high power, 19" mount

## Options

270221	OPT1	Frequency range Public safety: UL 380–385MHz / DL 390–395MHz
270222	OPT2	Frequency range Commercial: UL 410–415MHz / DL 420–425MHz
270223	OPT3	Frequency range Commercial: UL 415–420MHz / DL 425–430MHz
270224	OPT4	Special frequency range inside 380–430 MHz
270225	OPT5	Alarm notice via GSM/UMTS
270226	OPT6	External test point Down link (–30 dB)
270227	OPT7	Dual antenna output in Down link
270228	OPT8	Management system including: TCP/IP over Ethernet, web interface, alarm, forward and reverse power monitoring, remote software update (IAP)
270229	OPT9	Management system as in option 8 with GSM/UMTS interface
270230	OPT10	Management system as in option 8 with TETRA modem interface
270232	OPT12	Door alarm sensor
270233	OPT13	Separate RX and TX donor ports (only in combination with option 1)