

ACM-48 SYSTEM RACK

STANDARD INTEGRATED SYSTEM



when communication is **critical**

FEATURES

- Tailored to meet marine specifications
- 1-BIT digital audio technology (18.5 kHz)
- Typed approved solution for two way communication, talkback, public address and general alarm for all types of vessels
- Extensive set of features for PABX and emergency communication
- Supports VINGTOR integrated PA and GA solution
Wide range of audio terminals and signal units
- External communication and billing
- 19" swing frame provides easy access to terminals for installation and service
- Remote management and supervision using IP and Web technologies
- Redundant power input with switch over

Can be Customized with a set of optional packages:

- Up to 2x Analogue telephone gateway (4 or 8 channels)
- GSM telephone gateway
- IP DECT system
- Industrial data switch (4 ports)
- PoE industrial data switch
- Customized directory programming



DESCRIPTION

The VINGTOR ACM-48 Standard Integrated System is specially designed for use onboard ships. The system is based on the STENTOFON AlphaCom E exchange featuring the latest development such as IP telephony, Web management and IP switching.

The VINGTOR ACM solution supports a wide range of traditional, IP and wireless communication terminals made for ship environment. The ACM intercom terminals are type approved as integrated PA, GA, telephone and talkback units. IP DECT base stations connect directly to the exchange over IP providing a very cost efficient solution to deploy a wireless network onboard. The DECT telephones, IP telephones and intercom terminals have all access to the same set of ACM features. Users will be able to enjoy the benefits of one user experience and seamless mobility as they will always be contactable regardless where they are on the ship.

The system is type approved by DNV, Rina, CCS and CRS as an integrated communication system for two way communication, talkback, public address (PA) and general alarm (GA).

SPECIFICATIONS

Dimension (mm)	600W x 746H x 573D
Weight	70 kg
Mounting	Wall or floor mounted

ORDER NUMBER	DESCRIPTION	SHIP WEIGHT
3006204015	ACM-48 System Rack	77,0 Kg
1151004001	ACM-48 power supply option Only required if 24 VDC emergency is needed	2,0 Kg
1151004050	Multi relay board with 6 relays	

ACM-48 SYSTEM RACK, STANDARD INTEGRATED SYSTEM

Temperature range	0 - 55°C, recommended 18 - 25°C
Power	230 VAC MAINS with auto switch over to 230 VAC emergency Option 230 VAC MAINS with auto switch over to 24 VDC emergency
IP class	IP-22
Subscriber capacity	Prewired for 11 subscriber line boards Max 66 traditional intercom Max 132 analogue telephone Max 552 subscriber extensions
Integrated PA and GA interface	6 relay outputs (control signal) 6 inputs (control signal) 4 audio channels out 6 audio channels in PA zone selection require custom programming
Remote control	6 relay outputs to drive signal units Option for additional 2 relay cards
Audio technology	High resolution 1-Bit audio (18.5 kHz) – Wideband IP audio (8 kHz) – adaptive jitter buffers
External interface and billing	Option analogue telephone gateway Option GSM telephone gateway Option VINGTOR Billing system
IP multi-module	Up to 4 ACM exchange racks
Data interfaces	2 x 10/100 Mbps Ethernet AutoMDIX (RJ45) 1 x RS232 serial data (RJ45)
Data networking	Option 4 port industrial data switch Option 5 port industrial power over Ethernet switch
IP protocols	IP unicast - IP multicast - IP v4 - TCPUDP - Telnet - FTP – TFTP - NTP –HTTP - HTTPS - Syslog - SNMP v2c - SIP - RTP -RTCP - VoIP AlphaNet - STENTOFON data – OPC
Remote system management	AlphaPro over IP Web

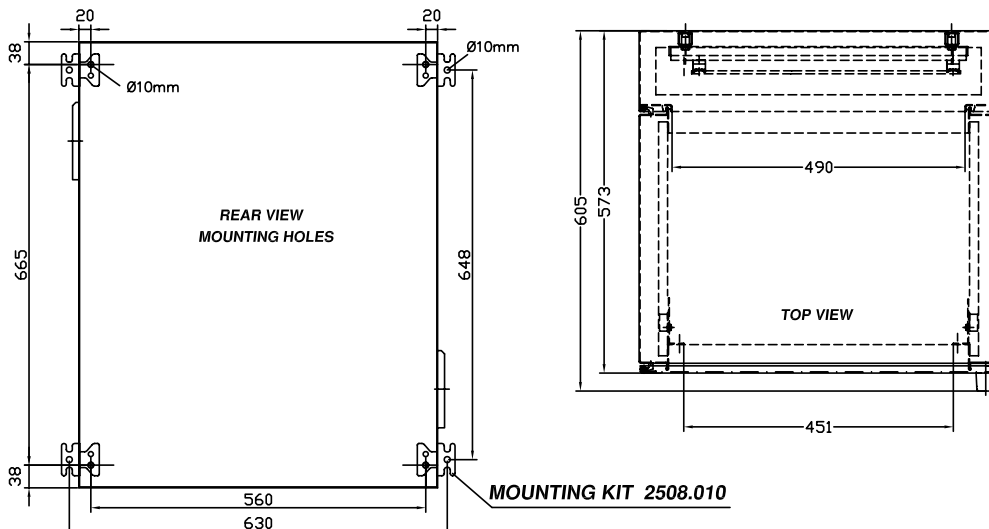
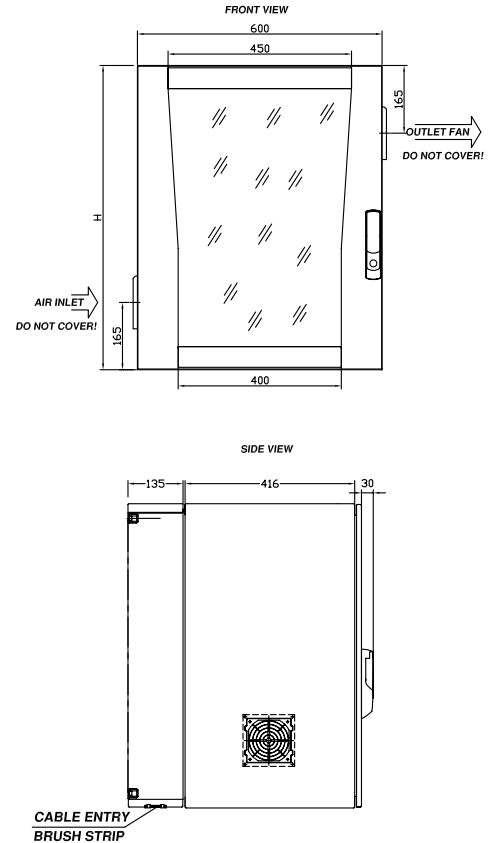

ORDER NUMBER

3006204015

DOC NO

A100K10653

16.12.2011

sales@vingtor.com

