

G0352

CABINET FOR 2 MODULES



when communication is **critical**

FEATURES

- **Sub - cabinet in a larger paging system**
- **It is well suited when you need an extra transmitter module to have full coverage throughout the vessel**
- **If even more transmitter modules are needed to have full coverage just add as many G0352 cabinets as needed**
- **A central unit module is always needed in the main paging central cabinet**
- **One module can be fitted inside except for the power supply**



SPECIFICATIONS

Power supply: 230VAC	230V AC
Power consumption	Max. 130W
Connection	Screw terminals
Cabinet colour	RAL 7032
Dimension (mm)	380W x 380H x 210D

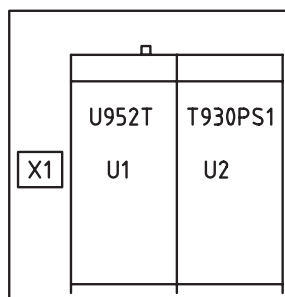
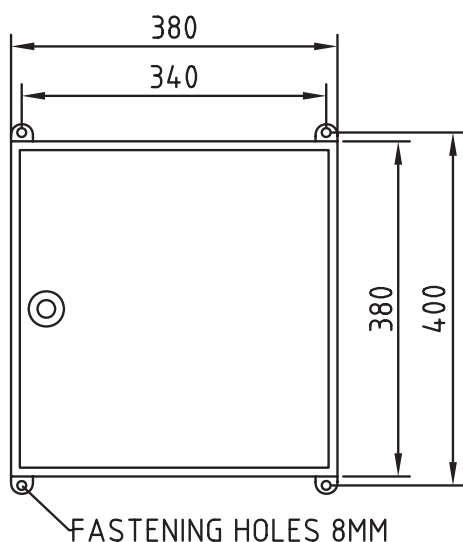

ORDER NUMBER	DESCRIPTION	SHIP WEIGHT
G0352	Cabinet for 2 modules complete with all terminals	

ORDER NUMBER
G0352

DOC NO
A100K10556

www.vingtor.com - sales@vingtor.com

