

1000670

## EBMDR-8-B

Exigo Button Expansion Module, 8 Buttons, Blue function LED



- ✓ Button expansion module for ECPIR-x
- ✓ Powered from ECPIR-x
- ✓ Eight programmable buttons with individual labels and status indicators
- ✓ Optional button protection covers
- ✓ Four units can be connected to one access panel

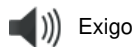

## Description

The EBMDR-8 button expansion module is developed for expanding the button capacity of the ECPIR-x access panels or intercom. Each button features eight fully programmable buttons that can be used to manually initiate alarms, select zones, or any other action in the Exigo system.

Each of the module's buttons features two independent indicators that show the status of the button's function. Up to four EBMDR-8 button expansion modules can be daisy chained to one console panel.

## Technical Dimensions

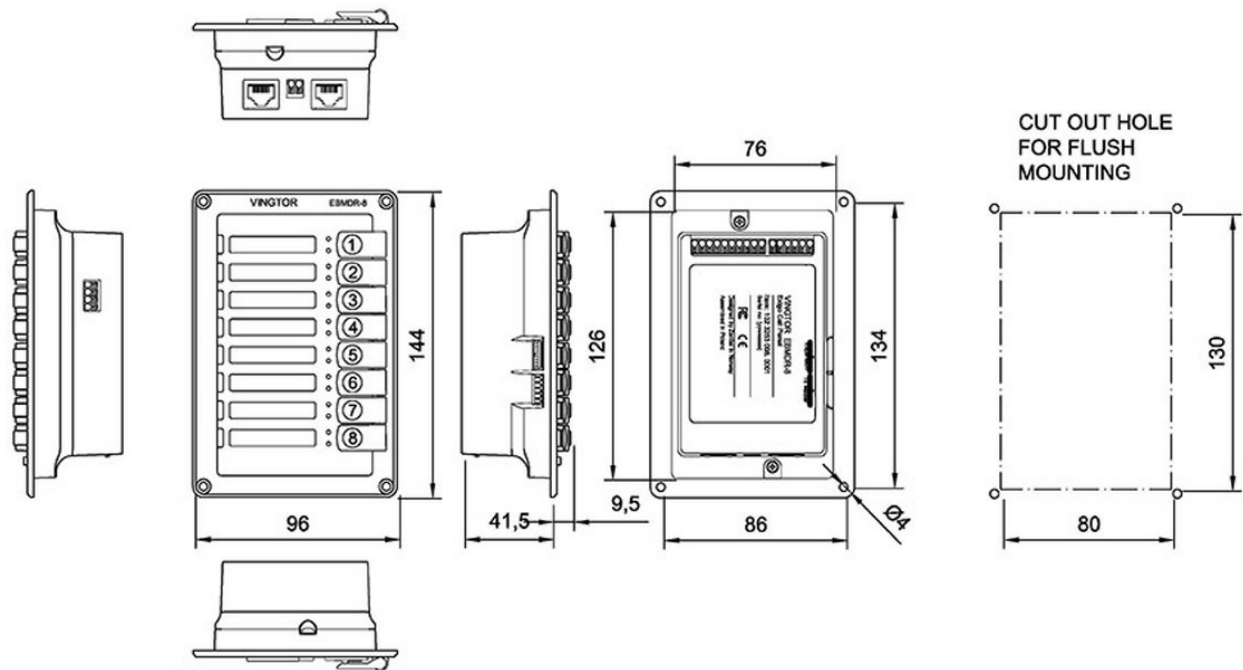

# Specifications

## MECHANICAL

Dimensions (HxWxD):	144 x 96 x 41.5 mm
---------------------	--------------------

Weight:	500 g
---------	-------

## ENVIRONMENTAL

Operating temperature:	-10°C to +60 °C
------------------------	-----------------

Operating humidity:	10% to 95% (non-condensing)
---------------------	-----------------------------

Storage temperature:	-40°C to +70°C
----------------------	----------------

Storage humidity:	10% to 95% (non-condensing)
-------------------	-----------------------------

Air pressure:	600 hPa to 1300 hPa
---------------	---------------------

IP rating:	IP-32
------------	-------

Magnetic Compass Safe Distance	60 cm
--------------------------------	-------

IEC 60945 Environmental Category	Protected
----------------------------------	-----------

Operator & Reading Distance	0,71 m
-----------------------------	--------

## CERTIFICATIONS

Immunity:	EN 60945, EN 50130-4, EN 61000-6-1, EN 61000-6-2, EN 55103-2, FCC-47 part 15B
-----------	---

Emissions:	EN 60945, EN 50130-4, EN 61000-6-3, EN 61000-6-4, EN 55103-1, FCC-47 part 15B
------------	---

Safety:	UL 60950-1, cUL 60950-1, CB to IEC 60950-1
---------	--

## Accessories



Product image not available



Product image not available

### EMBR-1

Mounting Box for ECPIR, EAPIR and EBMDR-8 Panels

Item Number: 1023595010

### EMBR-2

Mounting Box for ECPIR, EAPIR and EBMDR-8 Panels

Item Number: 1023595020

### Mounting plate for Exigo Access Panels - 2

Mounting plate for 2 pcs. Exigo Access Panel, 19" 4HU

Item Number: 2340140020

### Mounting plate for Exigo Access Panels - 3

Mounting plate for 3 pcs. Exigo Access Panel, 19" 4HU

Item Number: 2340140021

## Used With



### ECPIR-3P

Exigo Access Panel / Turbine Intercom

Item Number: 1023200033



### ECPIR-P

Exigo Call Panel, PTT Button

Item Number: 1023200030



### EAPIR-8

EXIGO Alarm Panel, 8 buttons

Item Number: 1023201008