

Configuration & Installation Manual

# Public Address & General Alarm System SPA-V2

# Contents

---

<b>1</b>	<b>Introduction.....</b>	<b>4</b>
1.1	About this Document.....	4
1.2	Publication Log .....	4
1.3	Related Documents .....	4
1.4	Rules and Regulations.....	4
<b>2</b>	<b>Installation &amp; Configuration Procedures.....</b>	<b>5</b>
2.1	General Description .....	5
2.2	Receiving and Inspecting the Equipment.....	5
2.3	Planning the Installation.....	5
2.3.1	Guidance Note.....	5
2.3.2	Environmental Requirements .....	6
2.4	Cable Requirements .....	6
2.5	Power Supply Requirements .....	7
2.6	Installation and Outline Specifications .....	7
2.6.1	Cabinets .....	7
2.6.2	Microphone Panels - Indoors.....	9
2.6.3	SPA-M6BOKS.....	9
2.6.4	SPA-AC6 & SPA-AC6-D Alarm Panels .....	9
2.6.5	ACBOKS.....	10
2.6.6	SPA-W1-V2 & SPA-W1-D Weatherproof PA Panels.....	10
2.6.7	SPA-W1AR-V2 & SPA-W1AR-D .....	11
2.6.8	SPA-W6A4 & SPA-W6A4-D.....	11
2.6.9	SPA-REM7.....	12
2.6.10	SPA-BOXM1 .....	12
2.6.11	VM15-RD/VM50-RD & VM15-RDF/VM50-RDF Volume Controls .....	12
2.6.12	STBOKS .....	13
2.7	Connecting Equipment.....	13
2.7.1	Connecting Power Supply 1 .....	13
2.7.2	Connecting Power Supply 2 .....	14
2.7.3	Connecting SPA-M1-V2 & SPA-AC6 .....	15
2.7.4	Connecting SPA-M1-D & SPA-AC6-D .....	16
2.7.5	Connecting SPA-M6 & SPA-AC6.....	17
2.7.6	Connecting SPA-M6-D & SPA-AC6-D .....	18
2.7.7	Connecting SPA-W1-V2 .....	19
2.7.8	Connecting SPA-W1-D .....	19
2.7.9	Connecting SPA-W1AR-V2 .....	20
2.7.10	Connecting SPA-W1AR-D .....	21
2.7.11	Connecting SPA-W6A4.....	22
2.7.12	Connecting SPA-W6A4-D.....	23
2.7.13	Connecting Loudspeaker in Single System.....	24
2.7.14	Connecting Loudspeaker & Volume Controls in Single Entertainment System..	25
2.7.15	Connecting Loudspeaker & Volume Controls in A+B System in Two Racks .....	26
2.7.16	Connecting Talk-Back System .....	27
2.7.17	Connecting PABX & Entertainment .....	27
2.7.18	Configuration Example 1: Microphone panels, PABX.....	28
2.7.19	Configuration Example 2: Microphone, Alarm Panels, PABX.....	29
2.7.20	Configuration Example 3: Dual PA/GA .....	30
2.7.21	Configuration Example 4: Required PA/GA Connection between Racks 1 & 2..	31
2.8	Jumper Settings for Configuration of Functions.....	32
2.8.1	Jumper settings on SPA Terminal Board .....	32
2.8.2	Jumper settings on SPA-EMS-V2 board (990-362).....	33
2.8.3	Volume Control Override .....	34
2.8.4	Jumper Settings on 4-Way Entertainment 6 Zones Board (990-363).....	35
2.8.5	Jumper Settings on SPA Multi 4-Way Entertainment 6 Zones Board (990-338)	35

2.9	Volume Adjustment on SPA Terminal Board .....	36
2.9.1	Signal Adjustment Talk-Back Input .....	36
2.9.2	Signal Adjustment Microphone Input .....	36
2.9.3	Signal Adjustment PABX Input.....	36
2.9.4	Signal Adjustment Entertainment Input .....	36
2.9.5	Signal Adjustment Amplifier Input.....	36
2.9.6	Volume Adjustment on Amplifier VPA-120/VPA-240/VPA-400.....	36
2.9.7	Volume Adjustment on Amplifier EA1400/EA1600 .....	37
2.10	Loudspeaker Power Consumption.....	37
2.11	Alarm Setup .....	37
2.11.1	Alarms and Priorities .....	37
2.11.2	Possible Configuration of Alarm Relay Boards.....	37
2.11.3	Frequency Change on Alarm.....	38
2.11.4	Alarm 1 .....	39
2.11.5	Alarm 2 .....	39
2.11.6	Alarm 3.....	40
2.11.7	Alarm 4 .....	40
2.11.8	Alarm 5.....	41
2.11.9	Alarm 6.....	41
2.11.10	Alarm 7.....	42
2.11.11	Alarm 8.....	42
2.11.12	Alarm 9.....	43
2.11.13	Alarm 10.....	43
2.11.14	Alarm 11.....	44
2.11.15	Alarm 12.....	44
2.11.16	Alarm 13.....	45
2.11.17	Alarm 14.....	45
2.11.18	Alarm 15 .....	46
2.11.19	FIRE Alarm .....	46
<b>3</b>	<b>Commissioning.....</b>	<b>47</b>
3.1	General .....	47
3.2	Mechanical Inspection .....	47
3.3	Cable Connection Inspection .....	47
3.4	Power Supply/Consumption Check .....	47
3.5	Function Configuration Check.....	47
3.6	Startup Procedure.....	48
<b>4</b>	<b>Appendix A: Local Mute.....</b>	<b>50</b>
<b>5</b>	<b>Appendix B: Custom Alarm Configuration Example.....</b>	<b>51</b>
<b>6</b>	<b>Appendix C: Alarm Tone Pattern.....</b>	<b>52</b>

## Figures

Figure 1	Available cabinet height options .....	7
Figure 2	Cabinet measurements front, side & rear .....	8
Figure 3	Fastening for 20U and higher racks.....	8
Figure 4	230 VAC and 24 VDC connections.....	13
Figure 5	230/230 VAC with SPA-FAIL board.....	14
Figure 6	Jumper for Entertainment Output to external system .....	32
Figure 7	Jumper for audio from Talk-Back system.....	32
Figure 8	Jumpers for Alarm Priorities.....	33
Figure 9	Jumpers for external audio out per zone .....	33
Figure 10	Jumpers for fire crew alarm per zone .....	33
Figure 11	Jumpers for PBX audio output per zone.....	33
Figure 12	Jumpers for Talk-Back with emergency message .....	33
Figure 13	Jumpers for override on All Call vs. zones 1-6 .....	34
Figure 14	Jumpers for override on normal & EMS vs. EMS only.....	34
Figure 15	Jumpers for override with internal or external 24 VDC .....	34
Figure 16	Alarm/Mic Panel with Local Mute for Dual System.....	50

# 1 Introduction

## 1.1 About this Document

The scope of this document is to provide relevant information on the installation, configuration, and commissioning of the SPA-V2 Public Address & General Alarm System for marine vessels.

The information in this document is aimed at System Administrators, System Installers and End Users.

## 1.2 Publication Log

Rev.	Date	Author	Comments
1.10	2008-3-15	JF	Published
2.0	2011-1-28	HKL	Revised text, figures & new profile
3.0	2013-3-19	HKL	Loudspeaker - Volume controls connections
4.0	2016-9-02	SEN	New alarm configuration & drawings updated
4.1	2017-4-26	SEN	Distance compass safety updated 2.3.2
4.2	2019-10-21	HKL	Phontech CIS Talk-Back
5.0	2020-3-6	HKL	EA1400/EA1600 included
5.1	2022-1-27	HKL	Note on Connecting talk-back system

## 1.3 Related Documents

Doc. no.	Documentation
A100K10369	SPA-V2 System Manual
A100K10371	SPA-V2 User Manual
	Project documents, drawings and SPA schematics
	Outline drawings in AutoCAD
	Amplifier and Entertainment manuals

## 1.4 Rules and Regulations

The SPA-V2 Public Address and General Alarm System is designed to meet the requirements in accordance with SOLAS:

- Section III, part B, regulation 6.4 and 6.5
- MSC.48(66) – International Life-Saving Appliance (LSA) Code
- MSC/Circ.808 – Public Address for passenger vessels
- MSC A.830(19) – Code on Alarms and Indicators, 1995

The system also meets additional requirements from the following class societies:

DNV, GL, BV, LR, RS, CCS, RINA, and ABS.

The SPA-V2 system and its components have been tested according to the following regulations:

- **IEC 60533: Second edition, 1999**  
“Electrical and electronic installation in ships - Electromagnetic compatibility”.
- **IEC 60945: Fourth edition, 2002**  
“Maritime navigation and radio communication equipment and systems - General requirements - Methods of testing and required test results”.
- **IACS E10: Corr.1 July 2003**  
“Unified environmental test specification - Testing procedure for electric control and monitoring, safety and protection, onboard computer based systems and peripherals, loading instruments, internal communication and other electrical equipment as considered appropriate”.

## 2 Installation & Configuration Procedures

---

### 2.1 General Description

This section describes the procedures for installing and configuring the SPA-V2 Public Address System. It is recommended that this section be read together with delivered project documentation before installing the system. The SPA system is designed for rugged use. However, as with any other electronic equipment, reasonable care and judgment must be exercised when handling this equipment. Hard shocks and rough handling may damage electronic components.

- ① *Note that this manual describes the standard SPA-V2 system and equipment. For systems with additional equipment and configuration, see project documentation and relevant manuals.*

### 2.2 Receiving and Inspecting the Equipment

Before unpacking the SPA system delivery, check the packing carton for signs of damage. Any damage to the carton should be reported to the supplier before proceeding further. When delivery is Ex Works, the transporter is liable for damages incurred.

Open the carton, carefully remove the contents and check for any signs of mechanical damage.

The SPA delivery package can, depending on the order, contain the following equipment (see attached packing list):

- Rack containing amplifiers, modules, etc.
- Microphone control panels and alarm control panels
- Technical and User manuals
- Microphones
- Speakers of different types

### 2.3 Planning the Installation

The design of the SPA rack depends on the functions that the system requires, i.e. whether it shall be a PA (Public Address) or a combined PA/GA (Public Address and General Alarm) system. (See section 2.)

To be able to plan the loudspeaker installation, you need the GA plan for the vessel. The number of loudspeakers required depends on whether the system is a PA or PA/GA system. GA for passenger vessels must have two systems, each in a different fire zone.

#### 2.3.1 Guidance Note

With reference to the Code and IMO Res. A. 830(19), sound pressure levels are defined as follows:

a) General Alarm

- Interior and exterior spaces: 80 dB (A) and at least 10 dB (A) above ambient noise levels.
- In sleeping positions and cabin bathrooms: 75 dB (A) and at least 10 dB (A) above ambient noise level.

b) Public Address

- Interior spaces, including sleeping positions and cabin bathrooms: 75 dB (A) and at least 20 dB (A) above ambient noise level.

- Exterior spaces: 80 dB (A) and at least 15 dB (A) above ambient noise level.

c) Under no circumstances should the audible alarm levels in a space exceed 120 dB

### 2.3.2 Environmental Requirements

The SPA system has been fully tested and fulfills all requirements according to EN 60945 and IACS E10 standards.

**Rack Temperature:** -15°C to +55°C

**Humidity:** At 25°C <95% RH, at 55°C <93% RH

**Compass safety:** Distance SPA rack: 180 cm  
Distance SPA -M family panels: 110 cm  
Distance SPA -W family panels: 80 cm  
Distance SPA-AC family panels: 10 cm

① *We strongly recommend installing the rack in a ventilated technical instrument room with temperatures between 18 °C and 25 °C. This will extend the life span of the system.*

## 2.4 Cable Requirements

All electrical cables and wiring external to the equipment shall be approved ship cable of type twisted pair with outer braided copper shield 0.75 mm<sup>2</sup> and at least of a flame-retardant type. This requirement is intended to comply with SOLAS Ch. II-1/45.5.2. The PA system has been fully tested and fulfills all requirements according to EN 60945 and IACS E10 standard.

Cables for service required to be operable under fire conditions are to be of fire-resistant type complying with the requirements of IEC 60331-1, where they pass through machinery spaces of category A and other high fire-risk areas other than those which they serve. For passenger vessels, this requirement also applies for cables passing through main vertical fire zones (IACS UR E15).

The following electrical services are required to be operable under fire conditions:

- Fire and General Alarm system
- Public Address system

Examples of high fire risk areas are, apart from machinery space of category A, galleys and pantries containing cooking appliances, laundry with drying equipment, spaces defined by paragraphs (8), (12) and (14) of SOLAS Ch.II-2 Reg. 9.2.2.3.2.2, and areas with fuel handling equipment.

Do not run the installation cable from microphone and alarm panels parallel or near to the installation cable for loudspeakers or power cables.

The shields must be interconnected in junction boxes and grounded in the SPA main unit only.

- Signal cable 0.75 mm<sup>2</sup>
- Power cable 230V AC 3x 2.5 mm<sup>2</sup>

- Power cable's dimension 24V DC must be calculated according to total power consumption.

① *The SPA unit must be connected to the vessel's central ground.*

## 2.5 Power Supply Requirements

The customer must provide a dedicated single phase power input which should adhere to the following recommendations:

- 230V AC, 50-60 Hz, fused and capable of delivering a maximum of 2A per 100 Watt amplifier.
- 24V DC Emergency power (if required), fused and capable of delivering a maximum of 8A per 100 Watt amplifier.
- Should be wired and fused independently from all other inputs.
- Must not be controlled by a switch.
- A warning tag should be attached to circuit-breaker-type fuses to prevent unauthorized manual operation.
- Proper grounding is essential for reliable operation

## 2.6 Installation and Outline Specifications

This section shows outline, panel cutout and mounting holes. Drawings are available in AutoCAD.

① *All dimensions are in mm.*

### 2.6.1 Cabinets

The cabinets are standard 19" racks with heights from 12U to 40U module units depending on the number of amplifiers, entertainment sources, monitors, and other modules in the actual installation.



Figure 1 Available cabinet height options

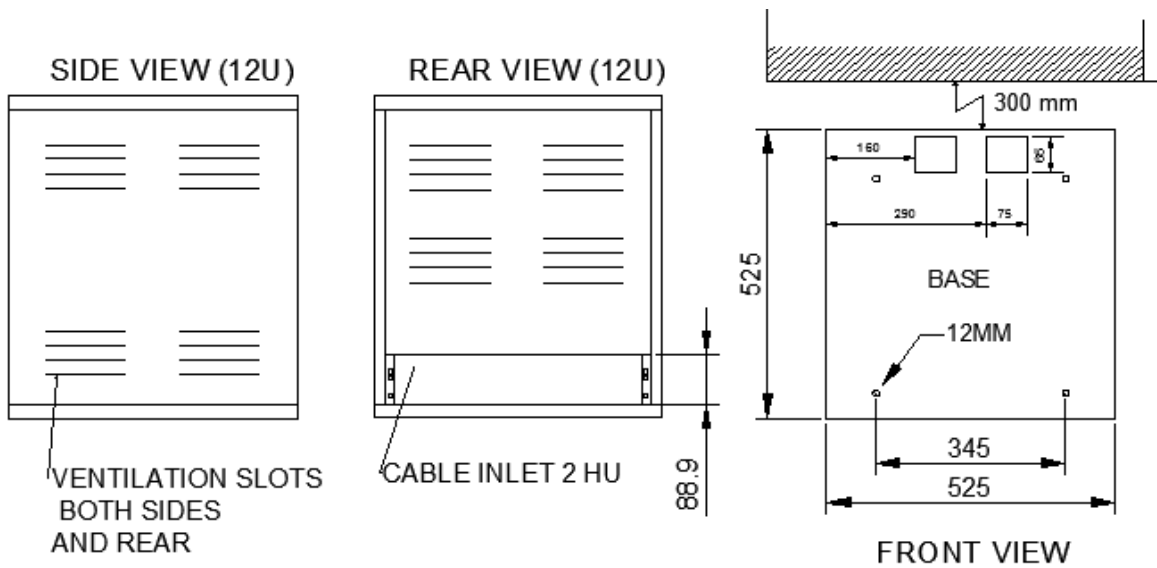

Figure 2 Cabinet measurements front, side & rear

**Please take note of the following:**

- Cable inlets should be realized through the rear of the cabinet.
  - The two 75 x 65 mm slots at the rear of the base are NOT recommended for cable inlets.
- For big and heavy racks, remove the heavy amplifiers before mounting. (It may be necessary with other fastening arrangements.)
- There are four 12 mm fastening holes for mounting the rack to the floor as standard.
- There are air ventilation slots on both sides and rear of all units.
- Free space on both sides should be minimum 300 mm.
- There is free space (134 mm) at the rear side of the rack for a cable run from the wall.
- The rack should be mounted at least 300 mm from the wall.
- Racks from 20HU and higher must be fastened at the top to the wall. (see figure)

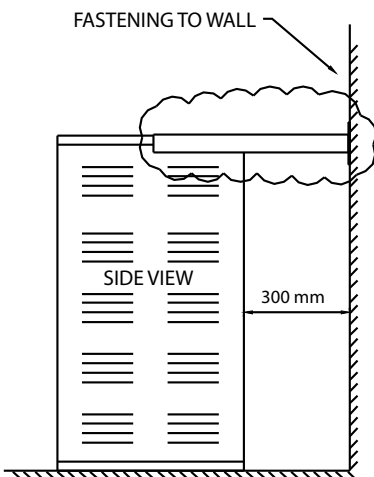

Figure 3 Fastening for 20U and higher racks

After installation, all cable termination, sub-boards and internal system equipment can be accessed by removing the lower front cover panels.



## 2.6.2 Microphone Panels - Indoors

SPA-M1-V2, SPA-M1-D, SPA-M6-V2,  
SPA-M6-D.

① SPA-M1-V2 version are equipped with 2x cable gland PG-16

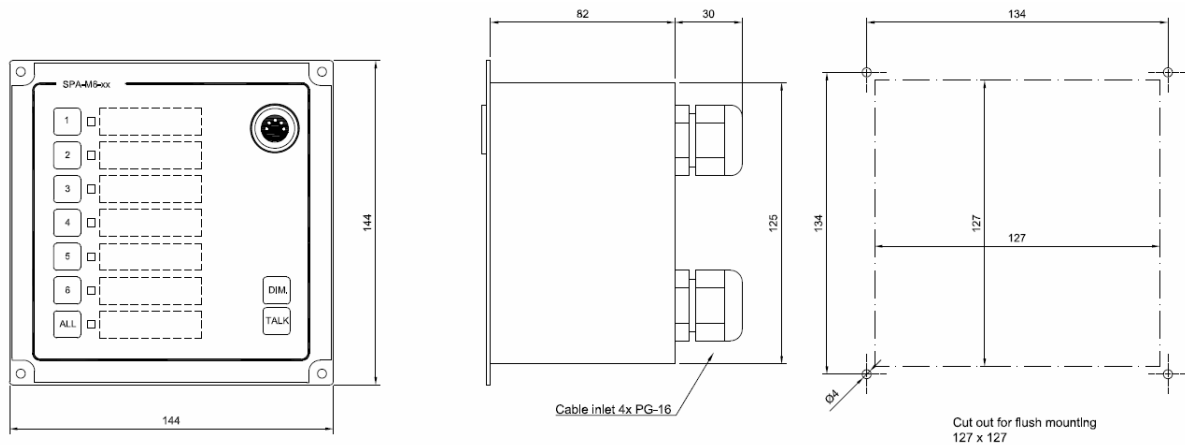

## 2.6.3 SPA-M6BOKS

For SPA-M1 and SPA-M6 when wall mounted.

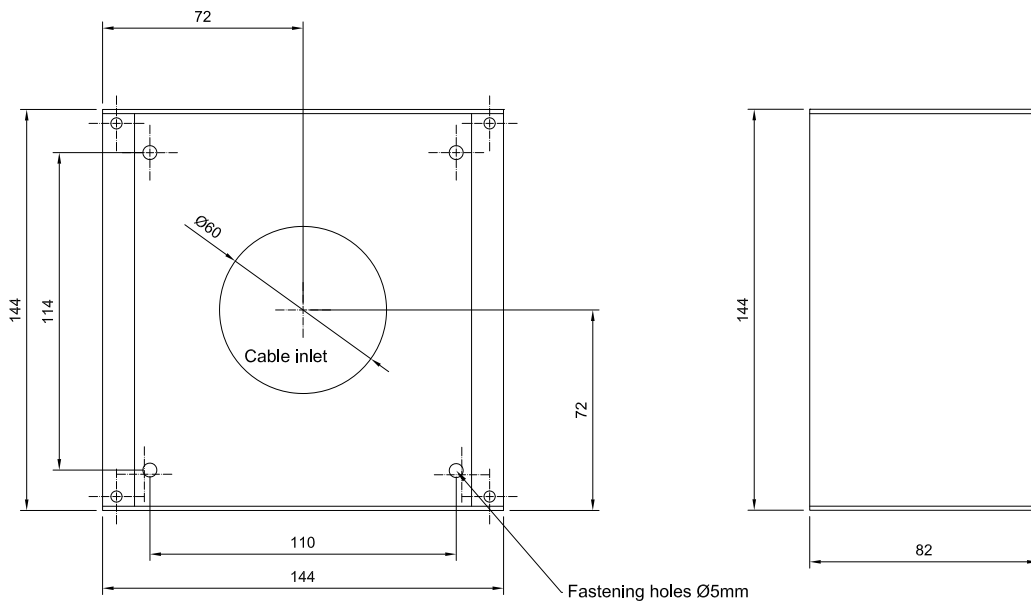

## 2.6.4 SPA-AC6 & SPA-AC6-D Alarm Panels

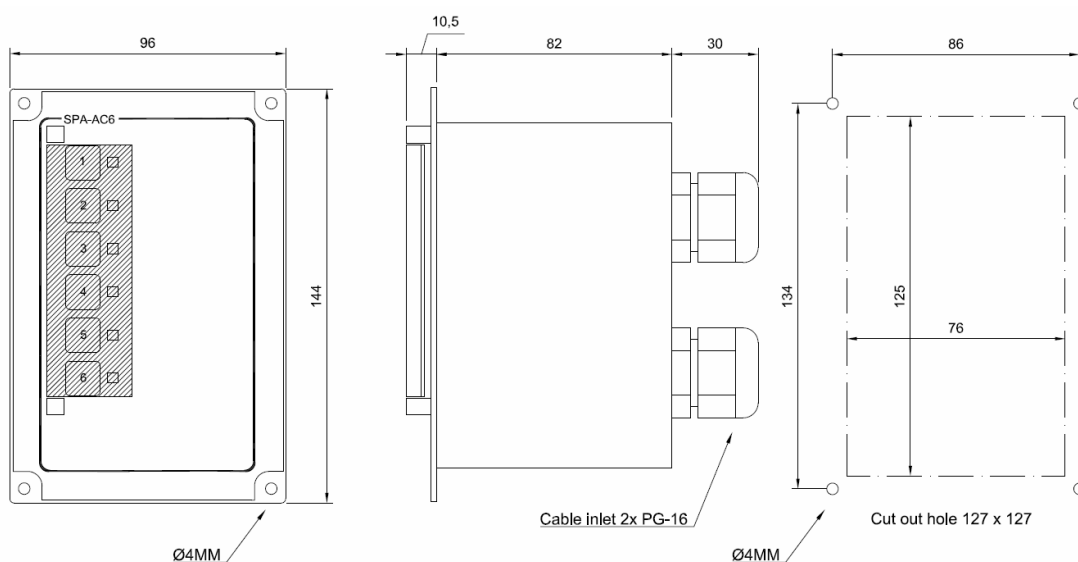

## 2.6.5 ACBOKS

For SPA-AC6 and SPA-AC6-D when wall mounted.

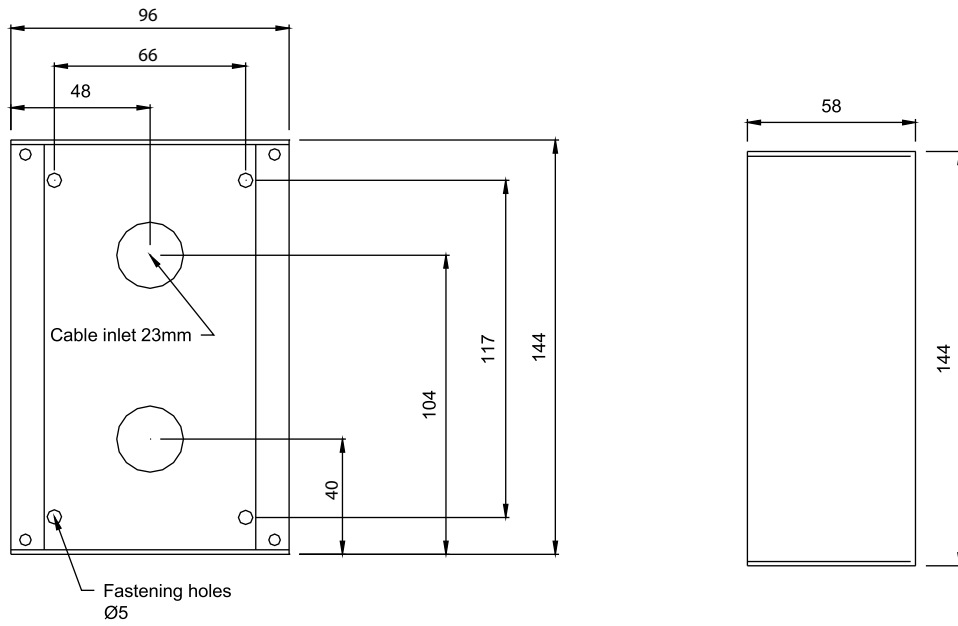

## 2.6.6 SPA-W1-V2 & SPA-W1-D Weatherproof PA Panels

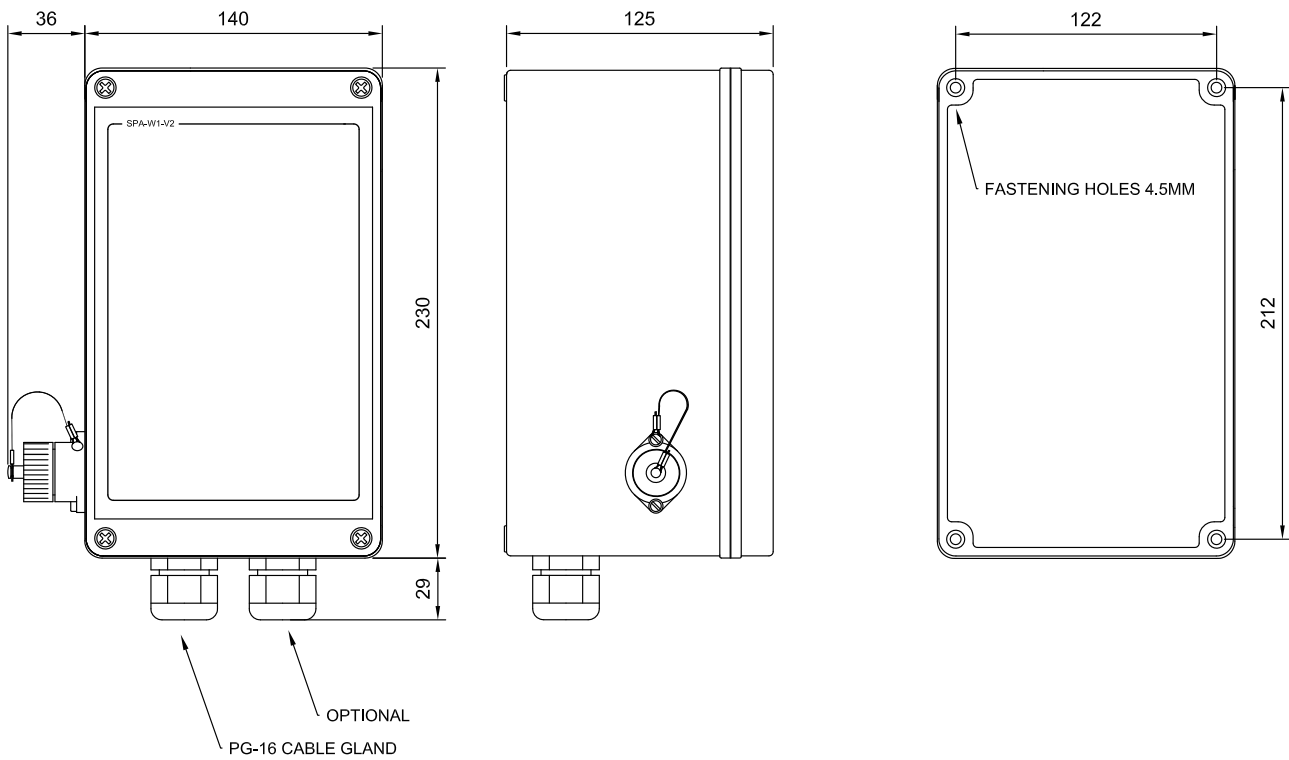

## 2.6.7 SPA-W1AR-V2 & SPA-W1AR-D

Weatherproof PA and alarm panel

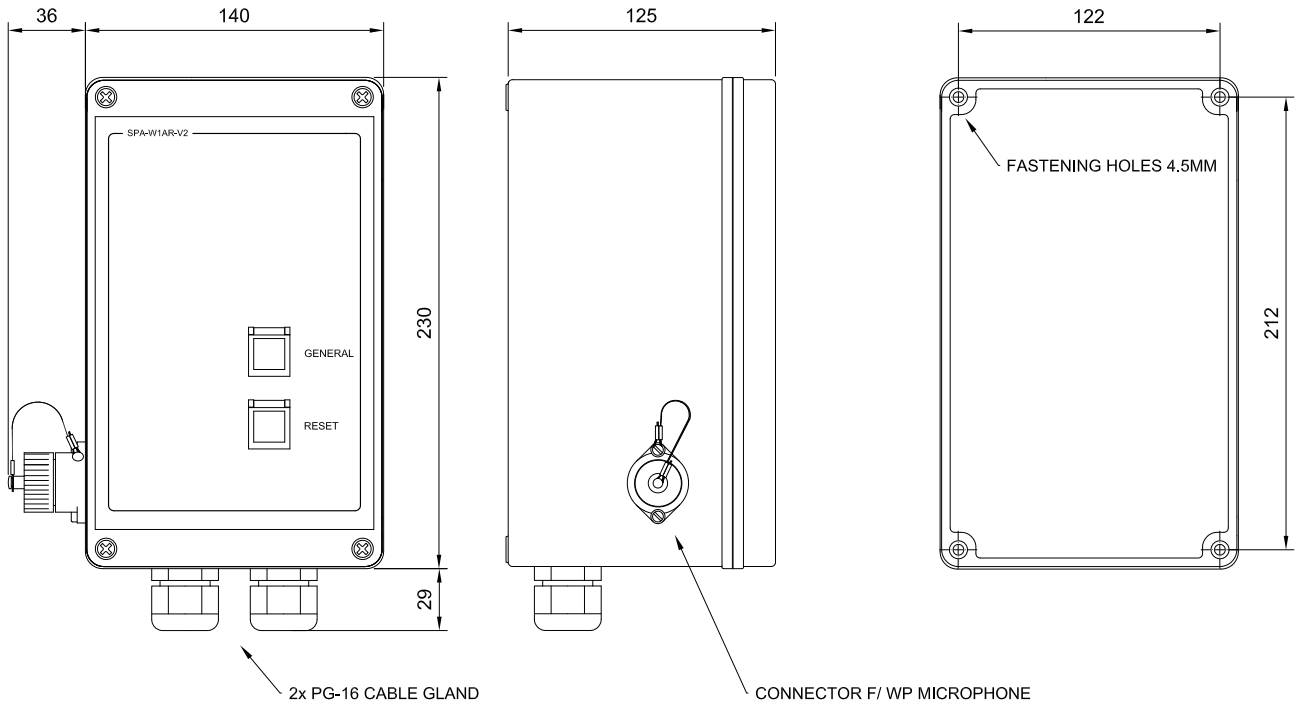

## 2.6.8 SPA-W6A4 & SPA-W6A4-D

Weatherproof PA and alarm panel

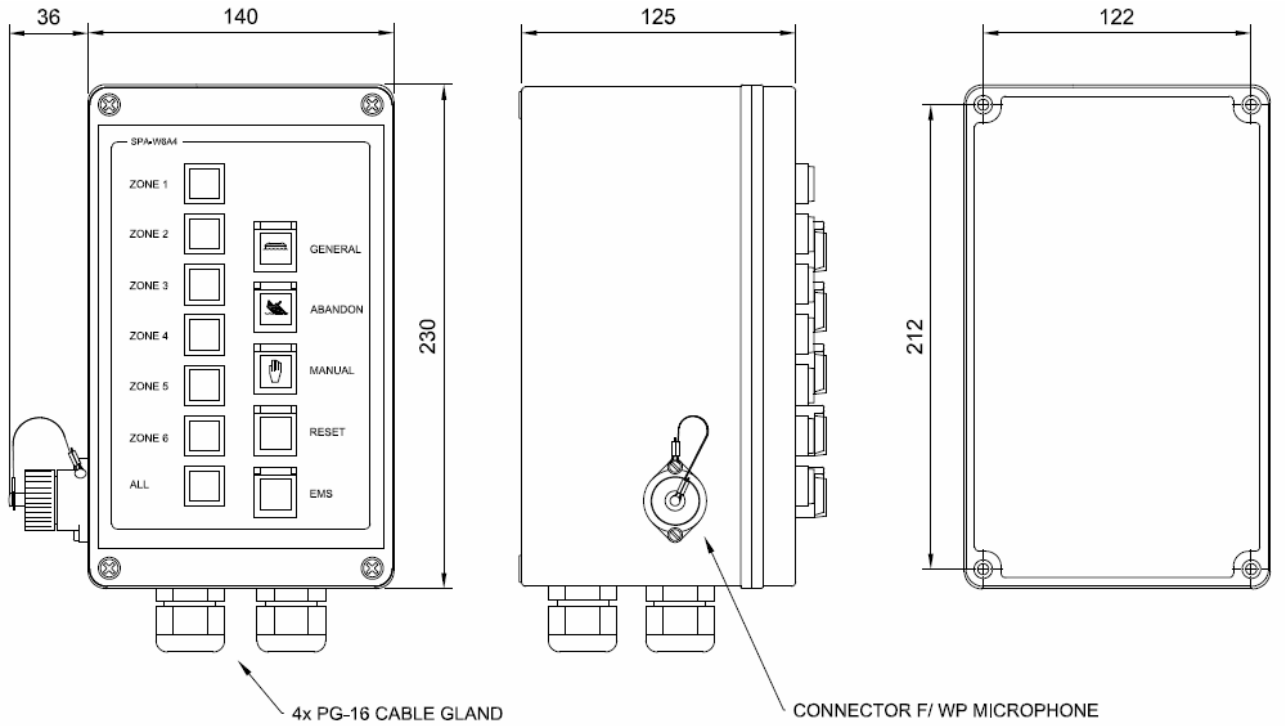

## 2.6.9 SPA-REM7

Remote panel for message recorder

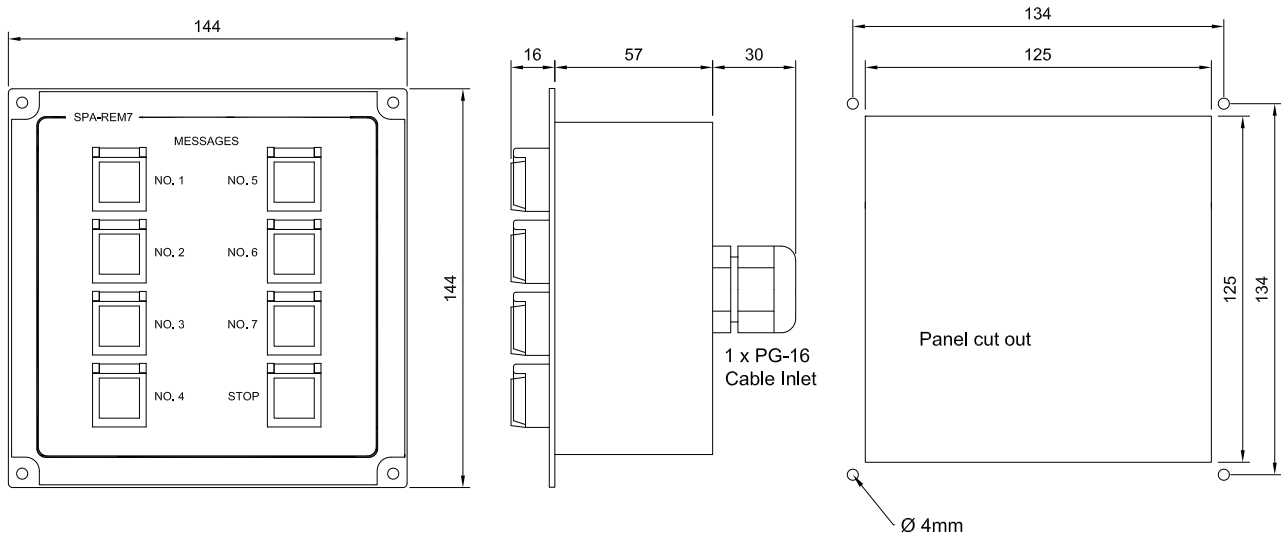

## 2.6.10 SPA-BOXM1

For VM15-R and VM50-R when wall mounted.

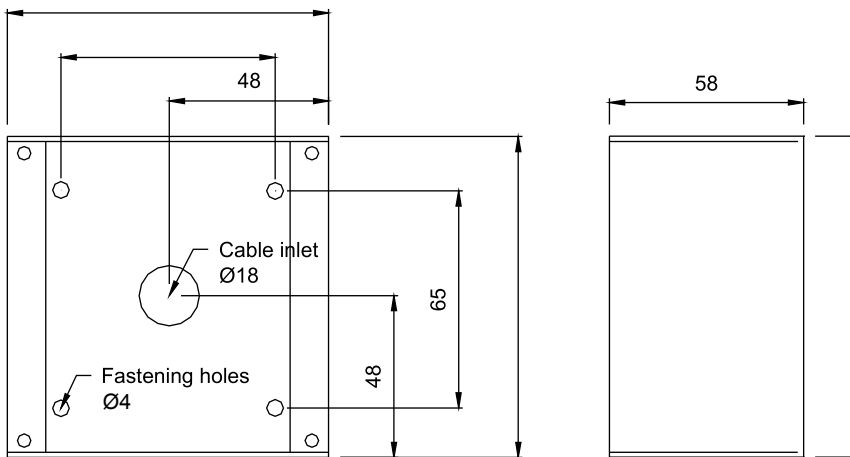

## 2.6.11 VM15-RD/VM50-RD & VM15-RDF/VM50-RDF Volume Controls

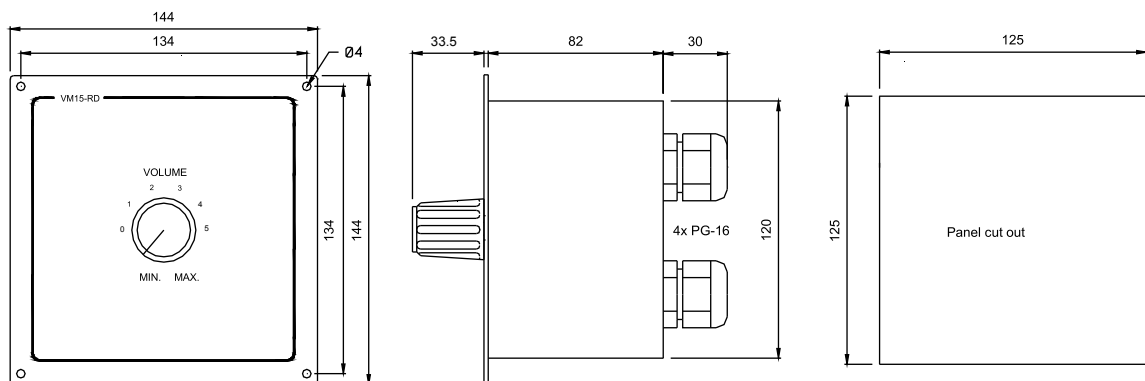

## 2.6.12 STBOKS

For VM15-RD/VM50-RD and VM15-RDF/VM50-RDF when wall mounted.

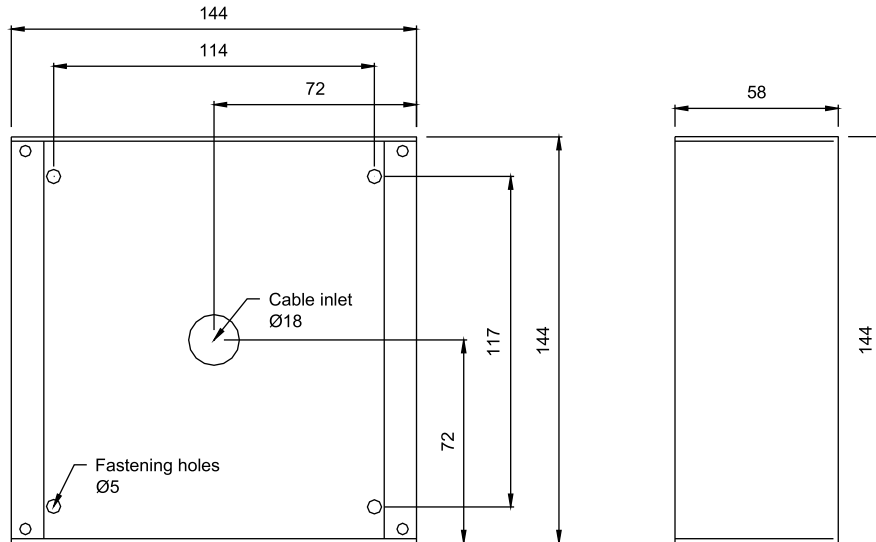

## 2.7 Connecting Equipment

This section shows drawings for each unit with marked terminal blocks and describes the connections between the units and the SPA rack. Typical system configurations are shown at the end of this section. (All drawings are also available in AutoCAD.)

### 2.7.1 Connecting Power Supply 1

230V AC main and 24V DC emergency.

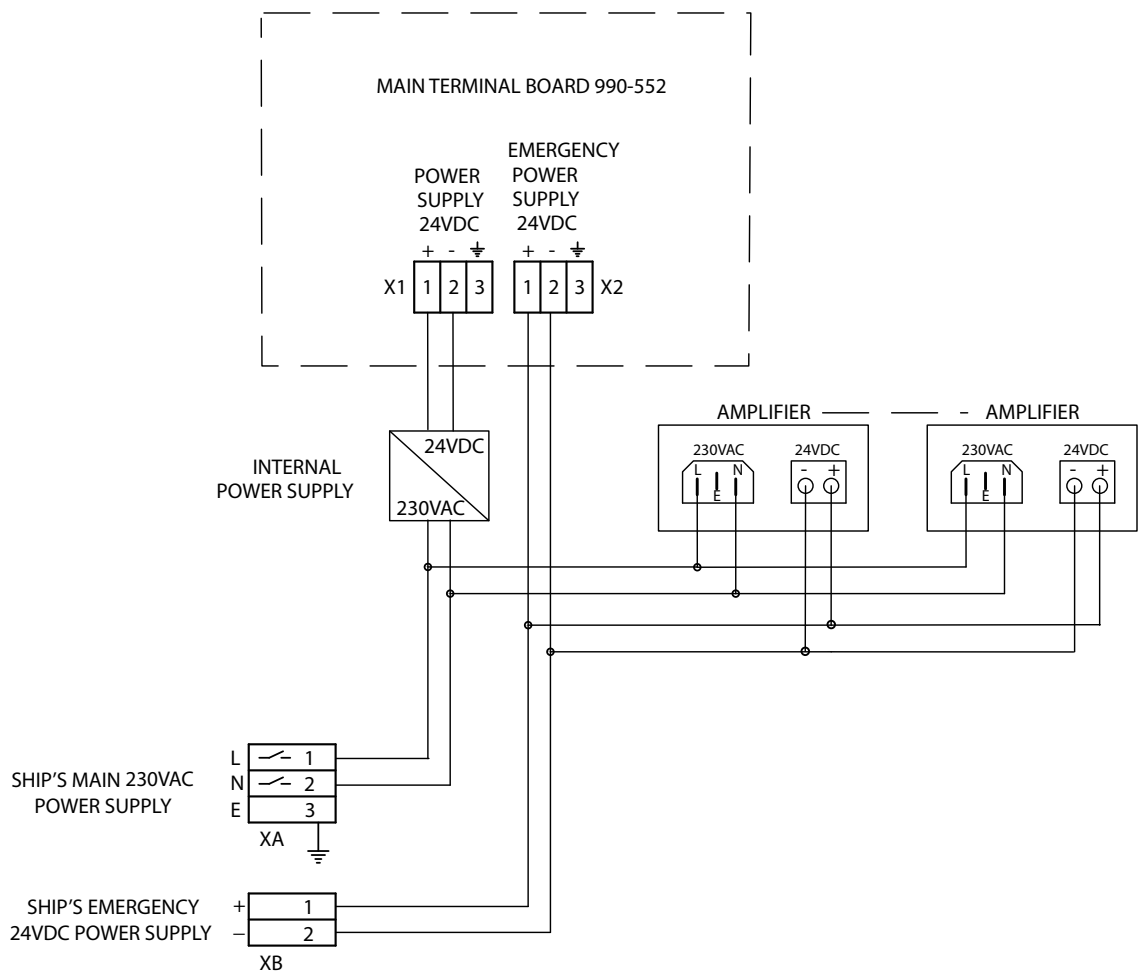

Figure 4 230 VAC and 24 VDC connections

## 2.7.2 Connecting Power Supply 2

230V AC main and 230 V AC emergency with failure unit SPA-FAIL.

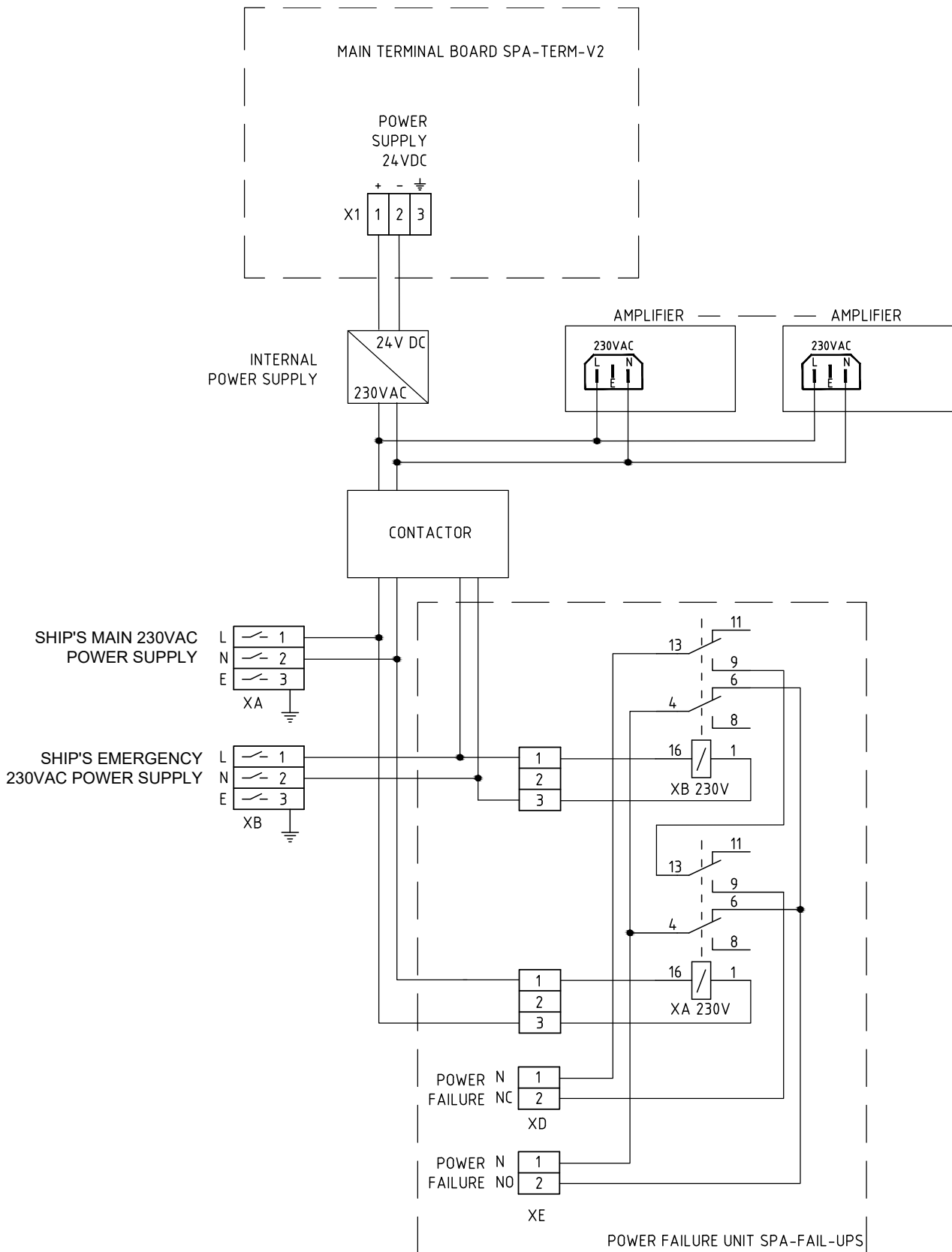
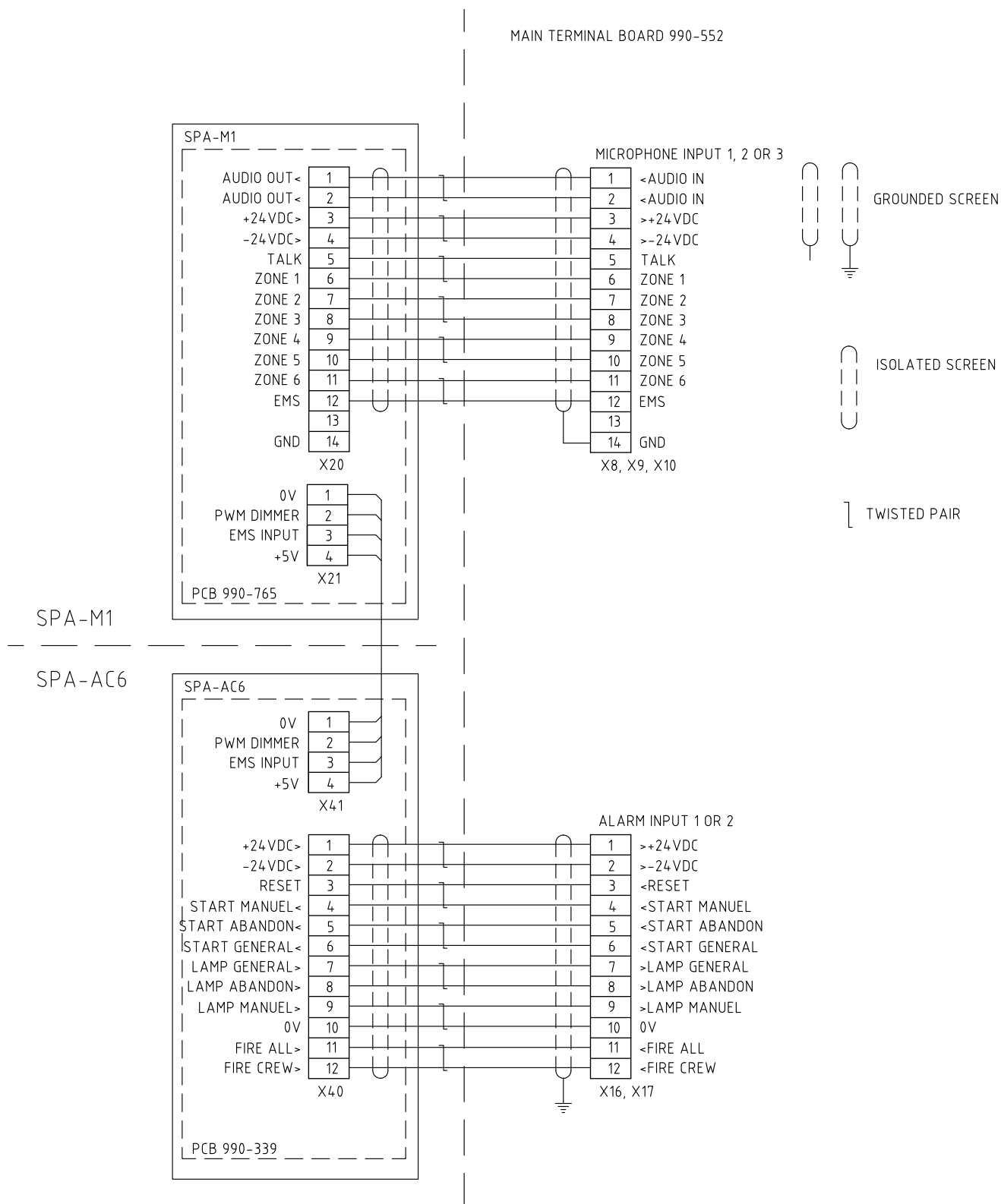

Figure 5 230/230 VAC with SPA-FAIL board

## 2.7.3 Connecting SPA-M1-V2 & SPA-AC6



**CABLE REQUIREMENT:**

Approved shipscale of type twisted pair with outer braided tinned copper screen. The screens must be interconnected in junctionboxes and grounded in a common groundpoint in the central unit only.

## 2.7.4 Connecting SPA-M1-D & SPA-AC6-D

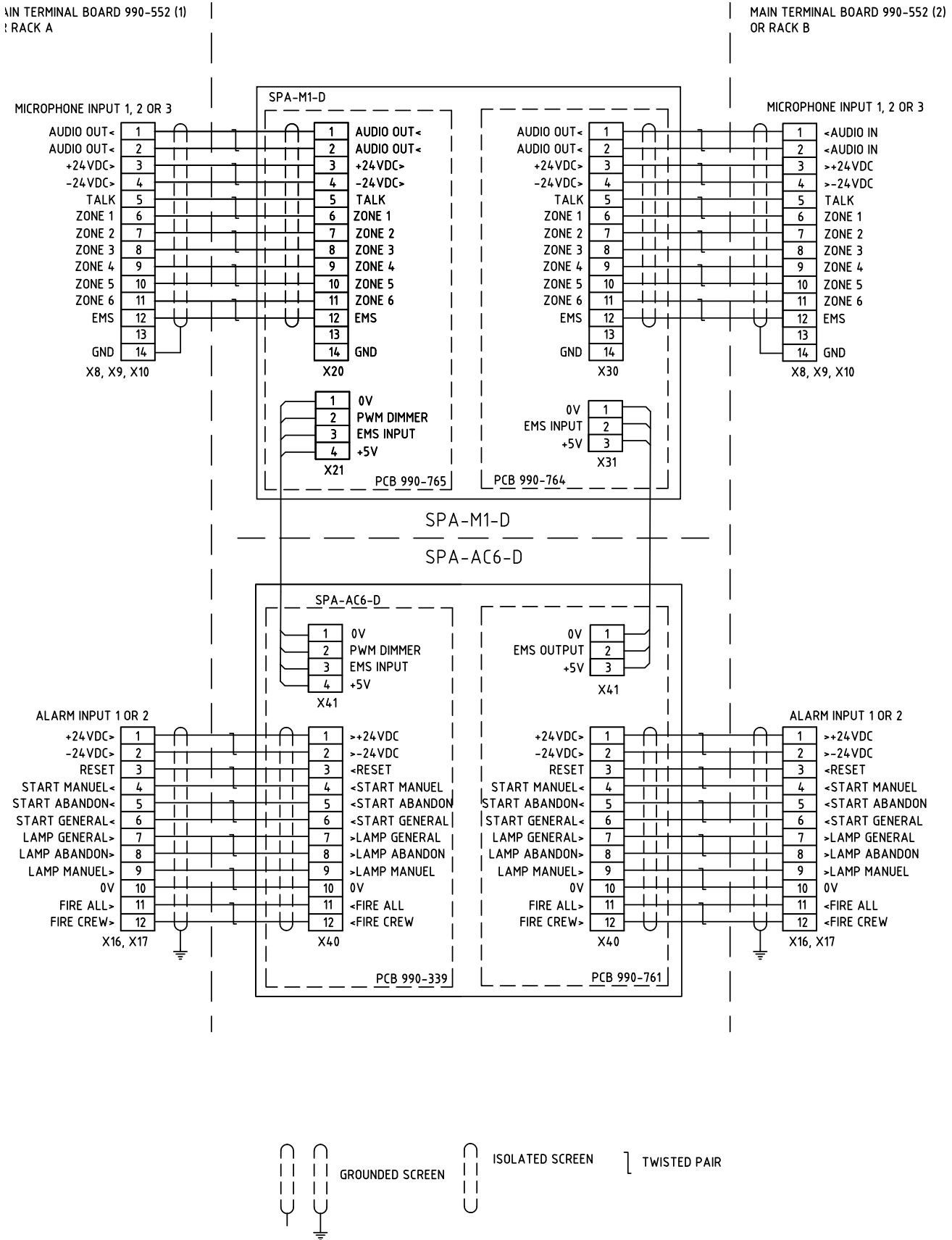

**CABLE REQUIREMENT:**

Approved shipscable of type twisted pair with outer braided tinned copper screen. The screens must be interconnected in junctionboxes and grounded in a common groundpoint in the central unit only.



## 2.7.5 Connecting SPA-M6 & SPA-AC6

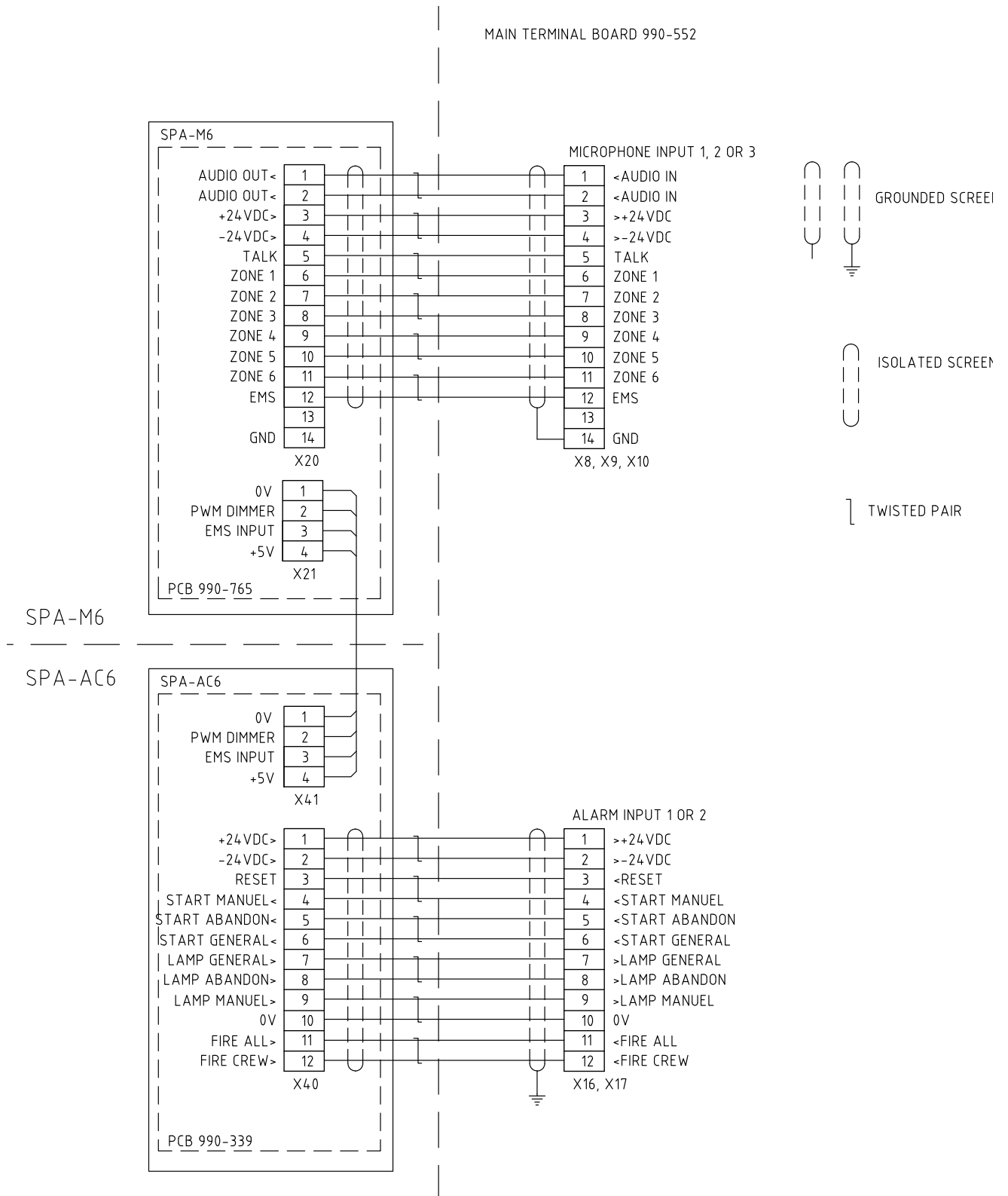

## 2.7.6 Connecting SPA-M6-D & SPA-AC6-D

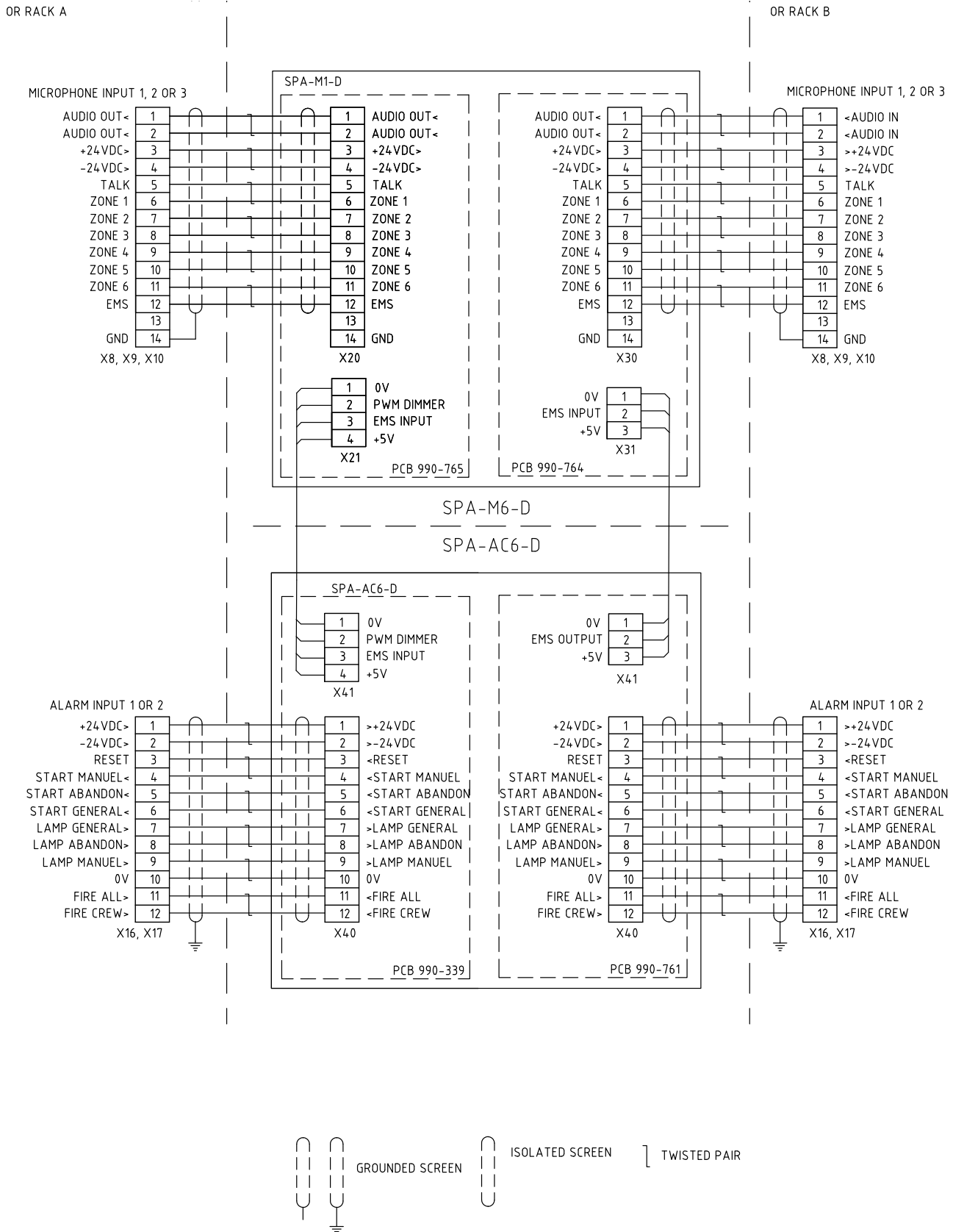

## 2.7.7 Connecting SPA-W1-V2

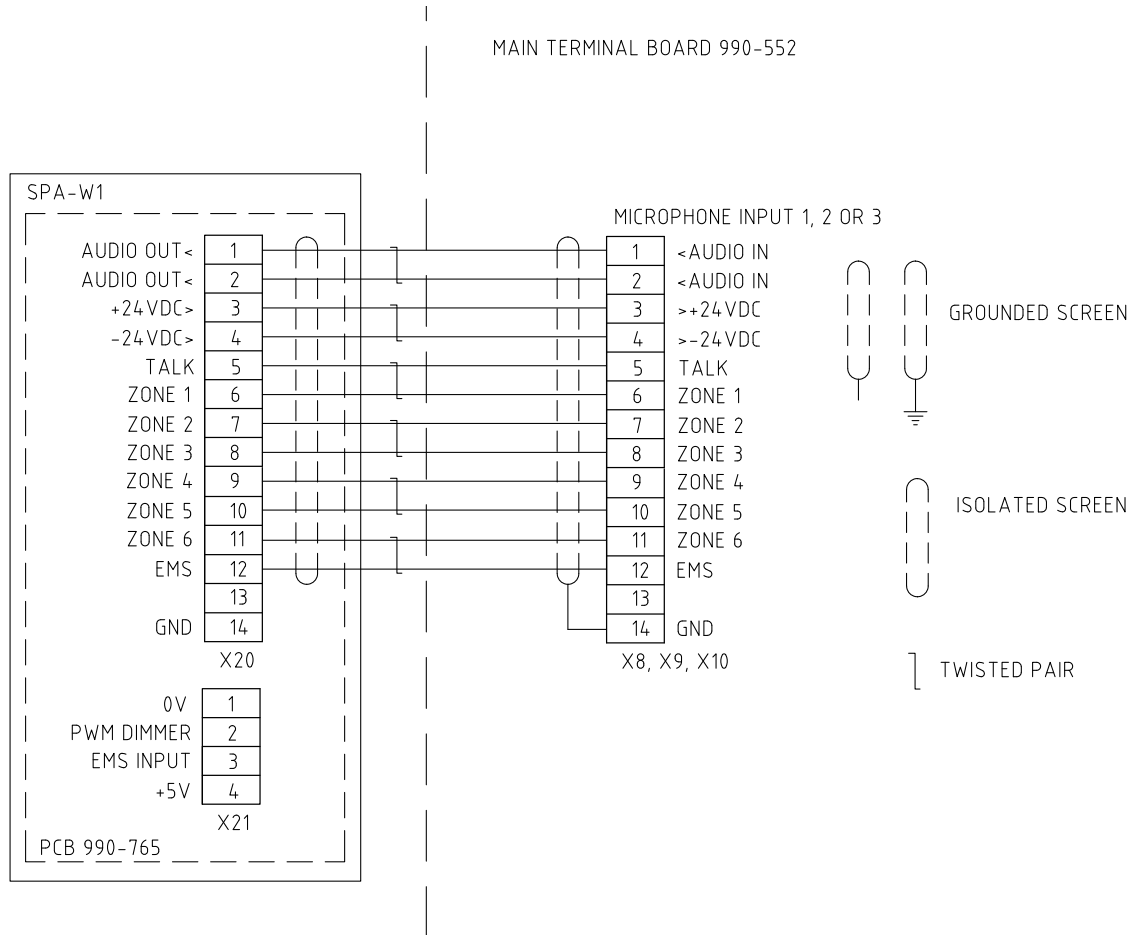

## 2.7.8 Connecting SPA-W1-D

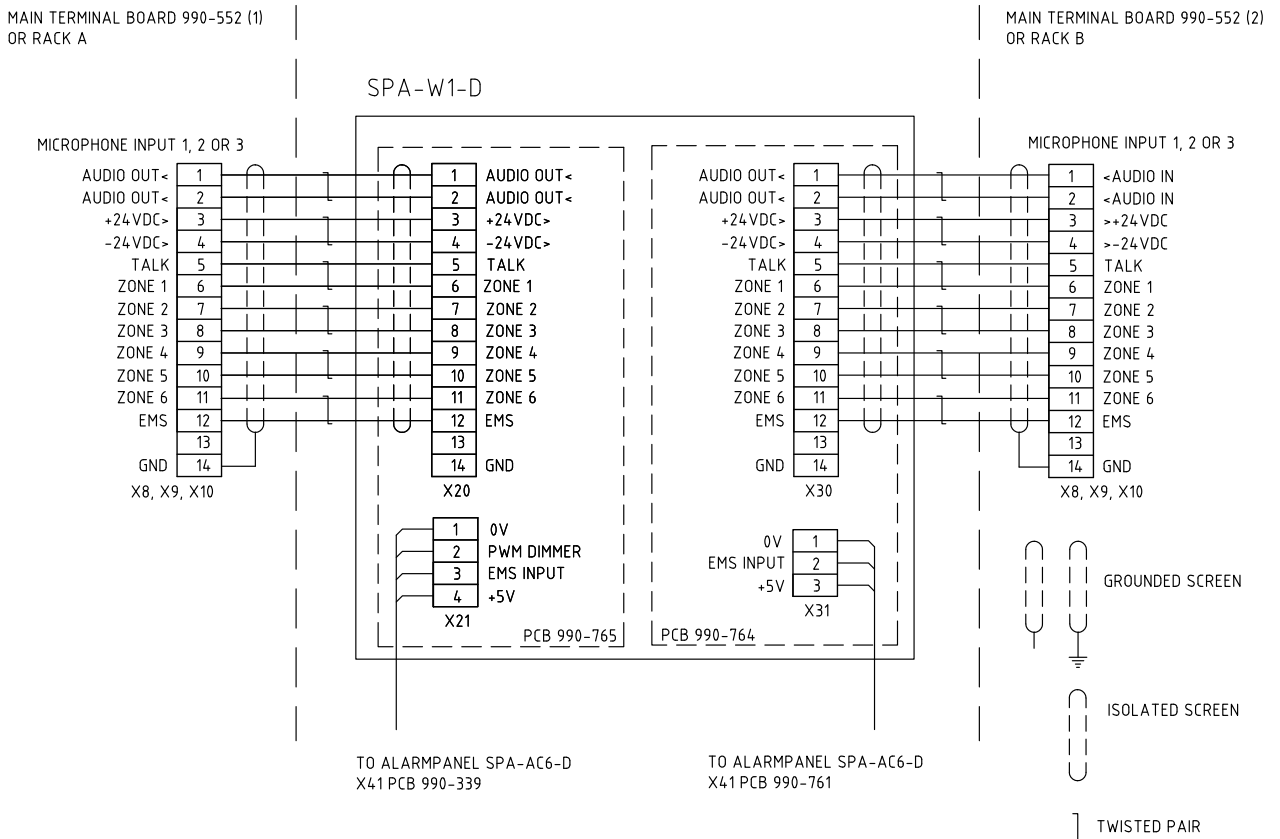

## 2.7.9 Connecting SPA-W1AR-V2

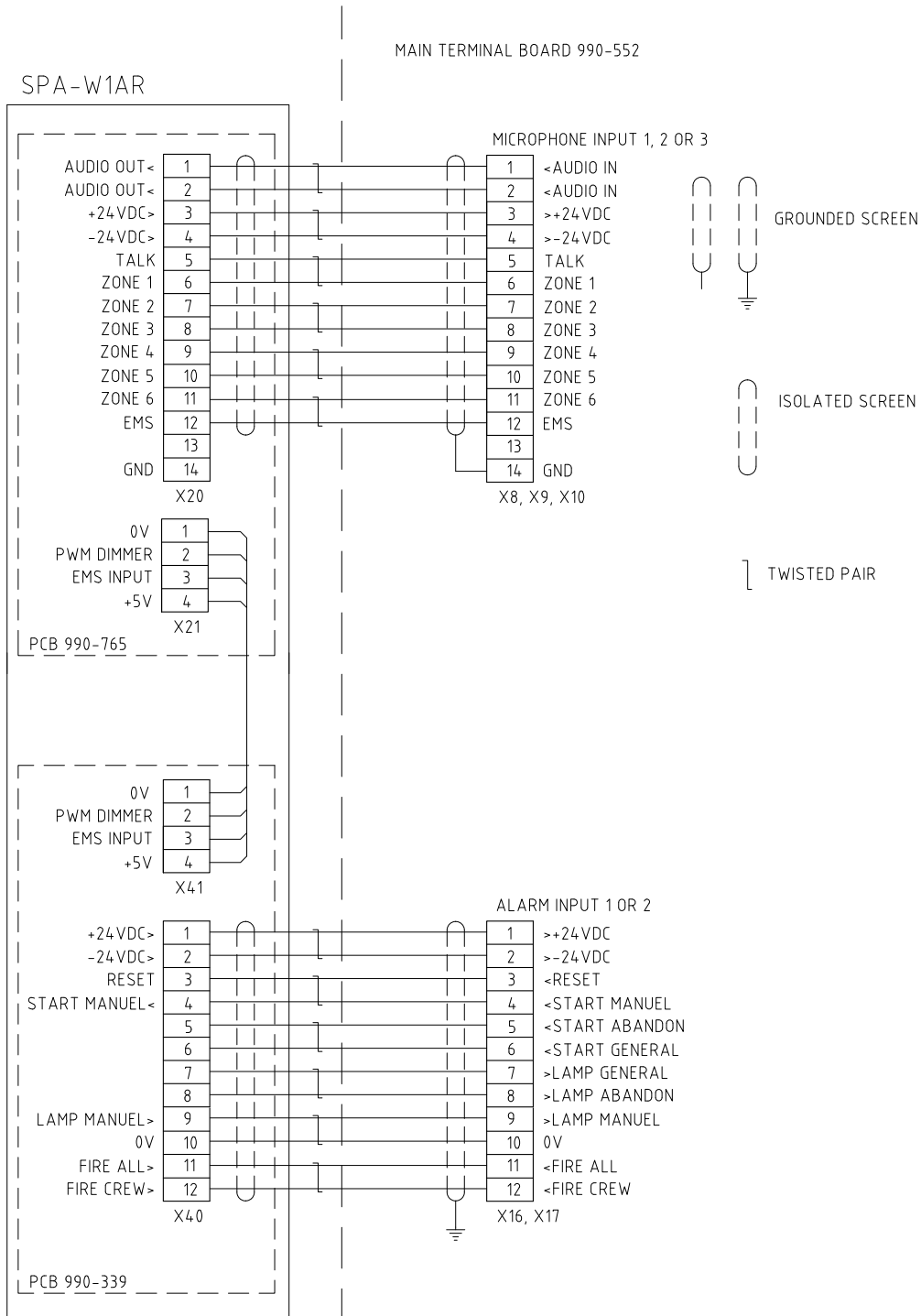

## 2.7.10 Connecting SPA-W1AR-D

MAIN TERMINAL BOARD 990-552 (1)  
OR RACK A

MAIN TERMINAL BOARD 990-552 (1)  
OR RACK B

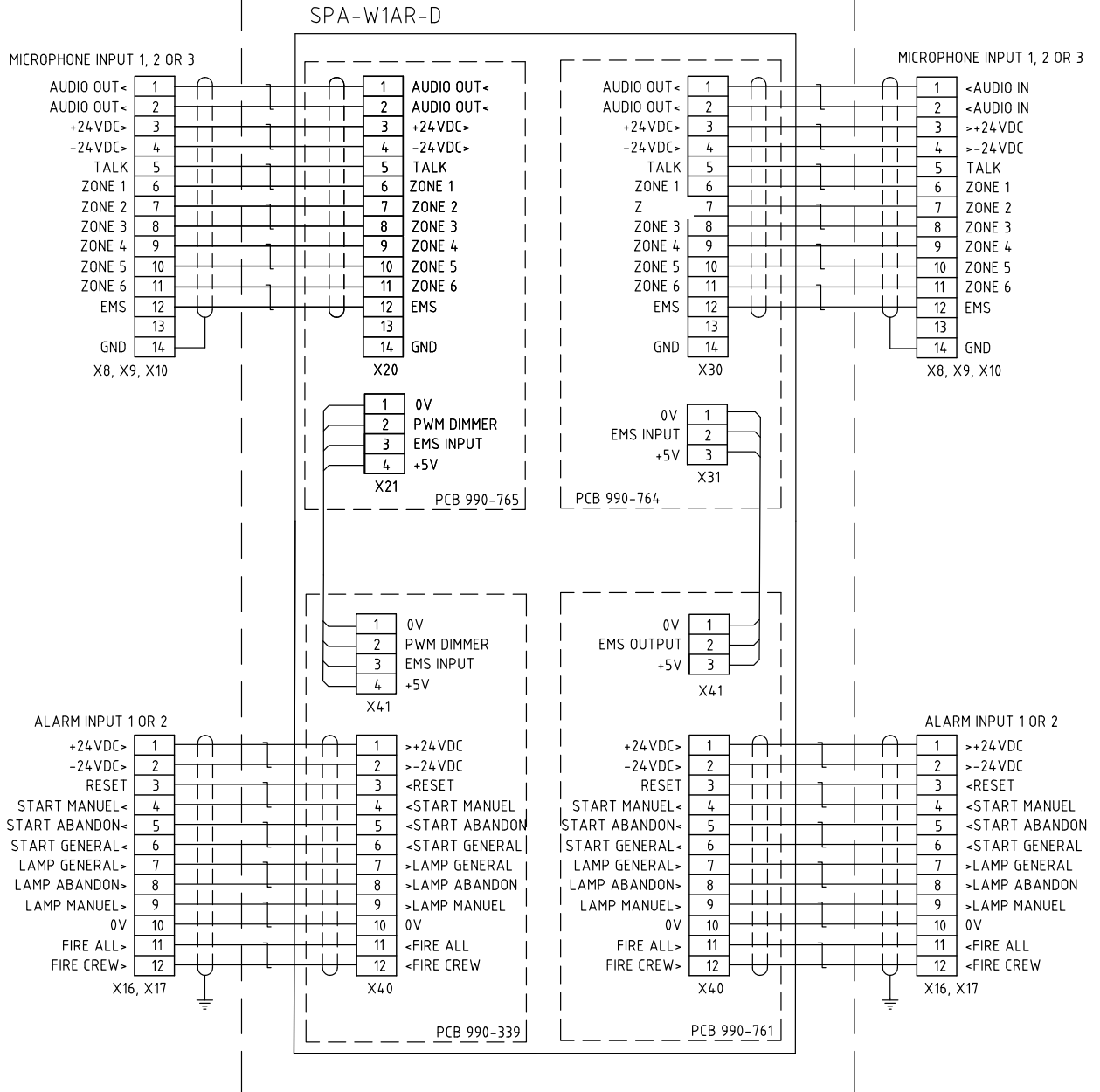

## 2.7.11 Connecting SPA-W6A4

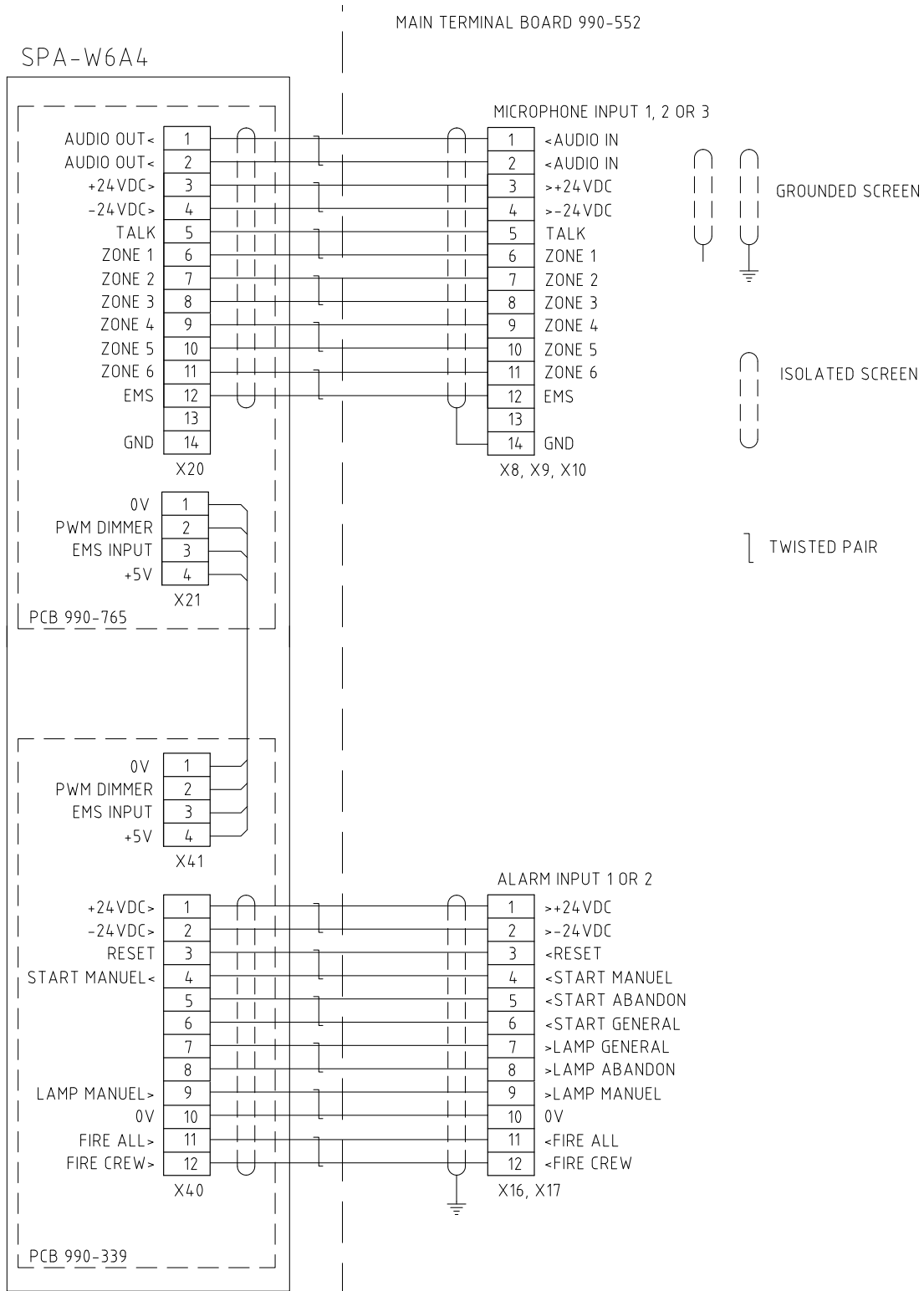

## 2.7.12 Connecting SPA-W6A4-D

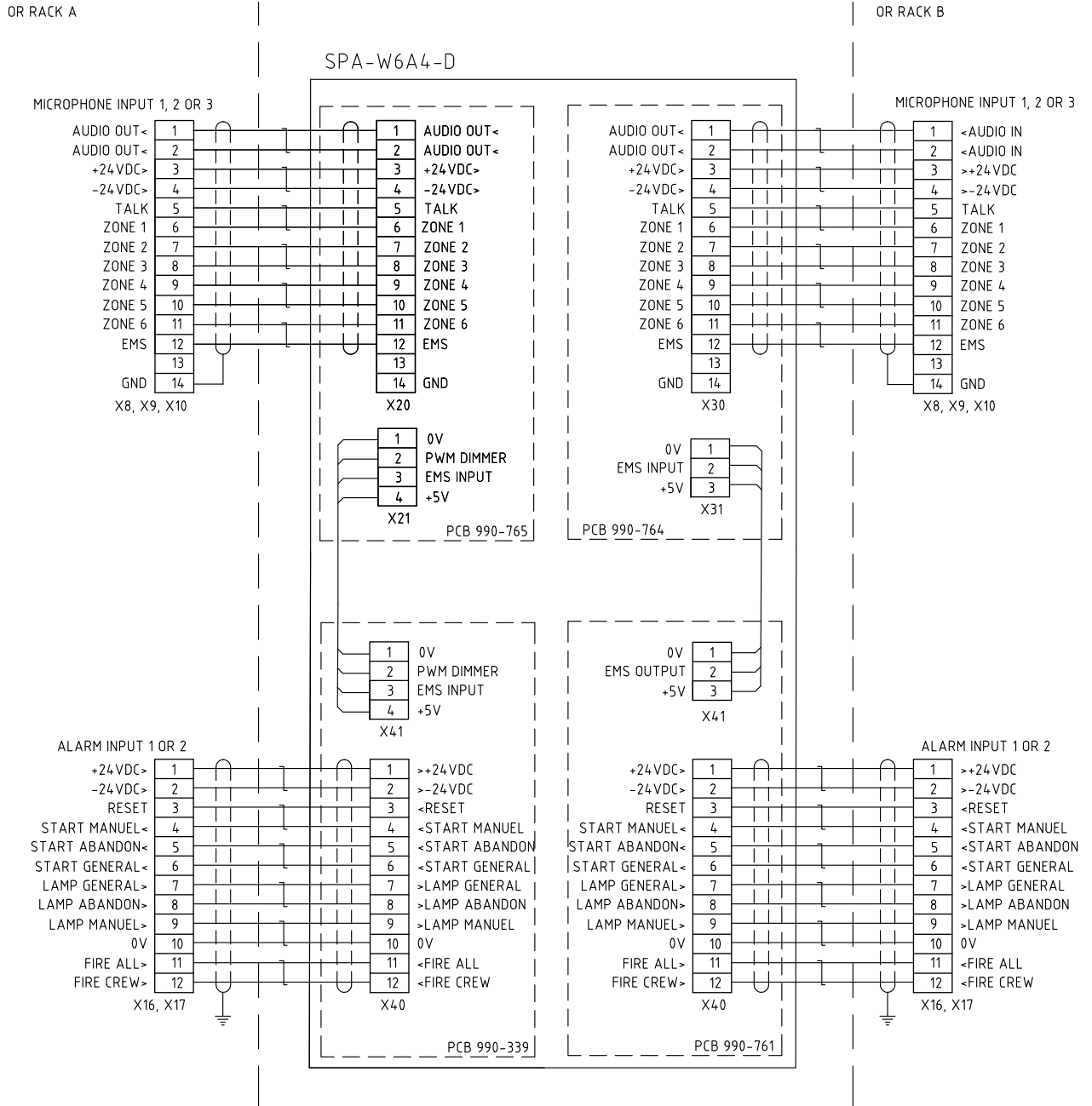

## 2.7.13 Connecting Loudspeaker in Single System

MAIN TERMINAL BOARD SPA-TERM-V2

100V LINE OUT

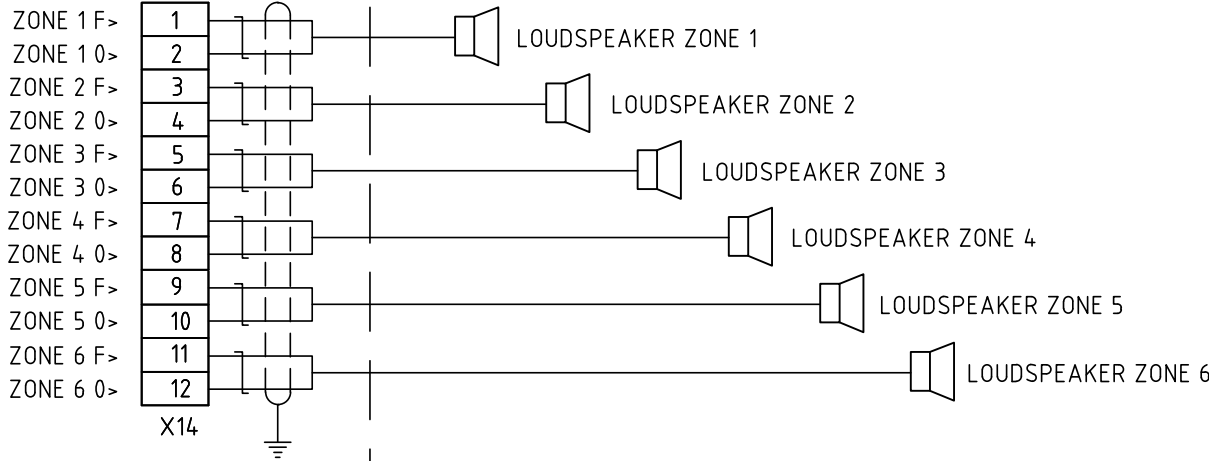

OPTIONAL CONNECTION ON  
MULTIZONE BOARD SPA-MUL-V2

100V LINE OUT

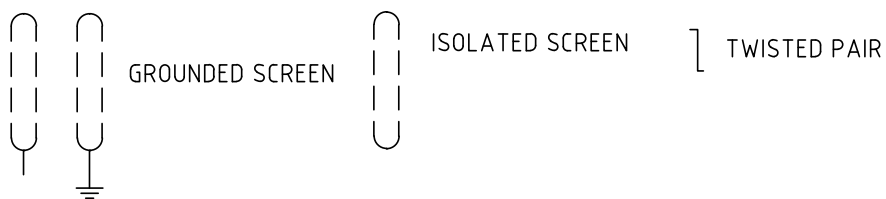
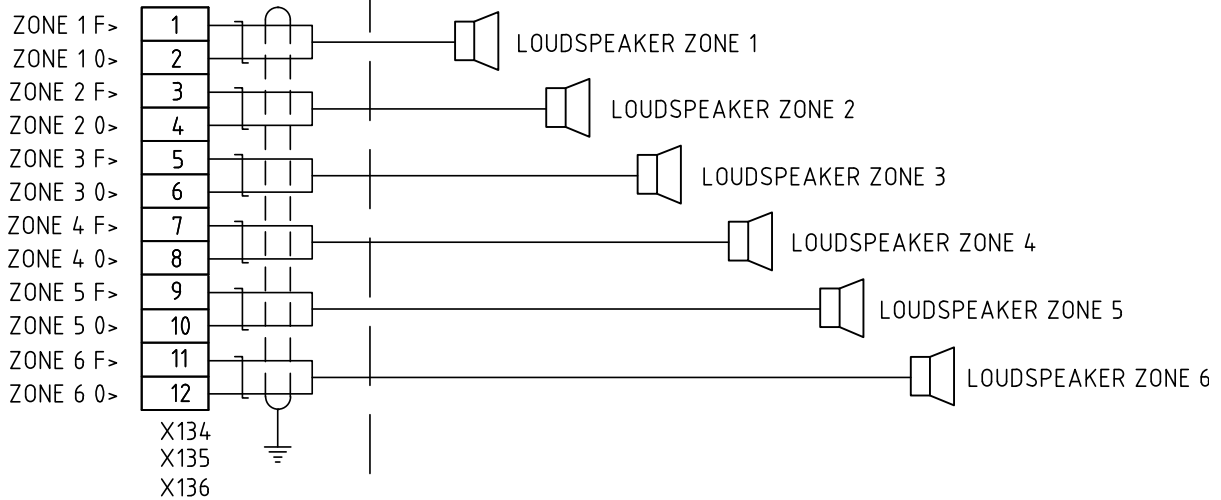



## 2.7.14 Connecting Loudspeaker & Volume Controls in Single Entertainment System

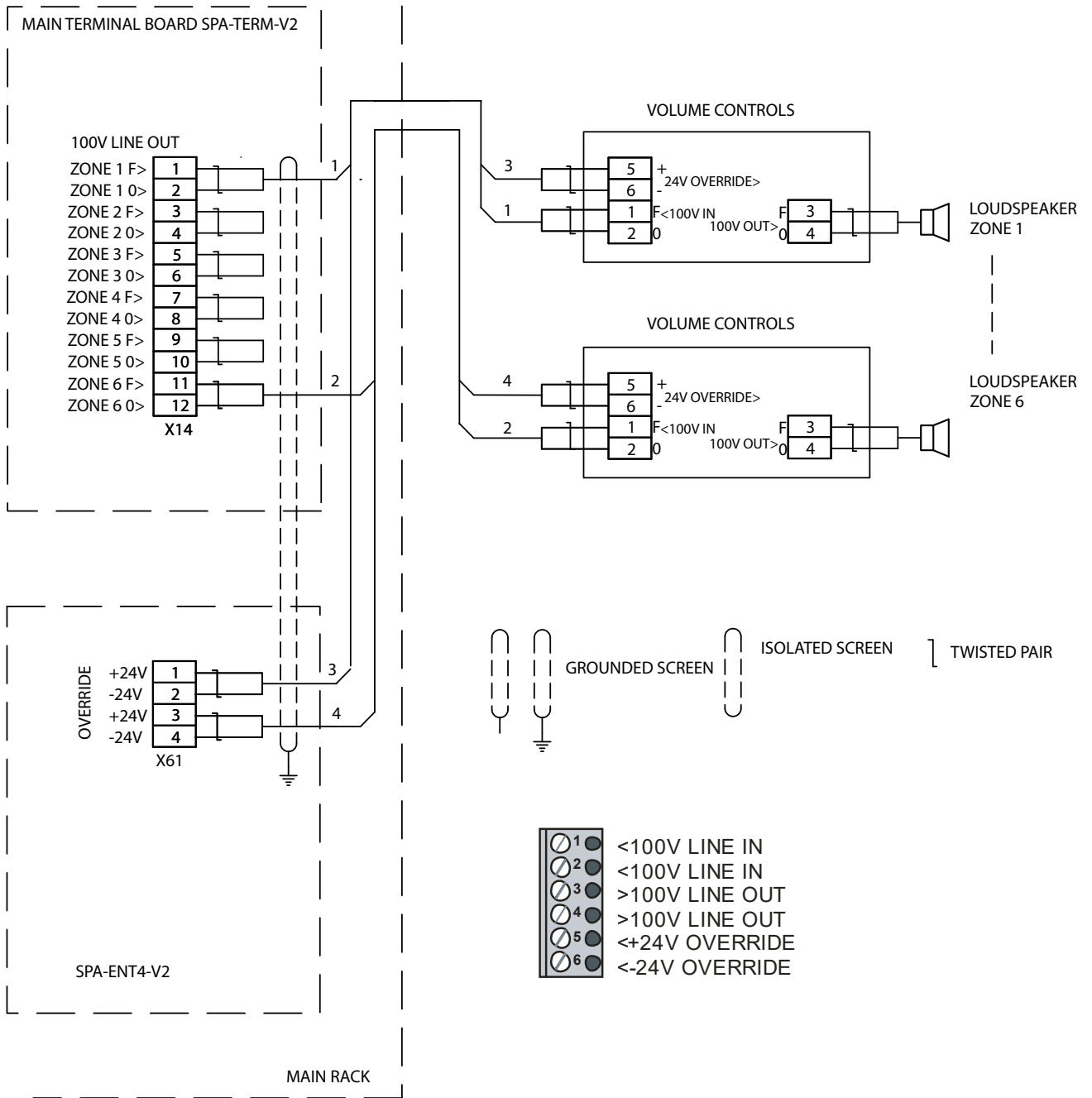

## 2.7.15 Connecting Loudspeaker & Volume Controls in A+B System in Two Racks

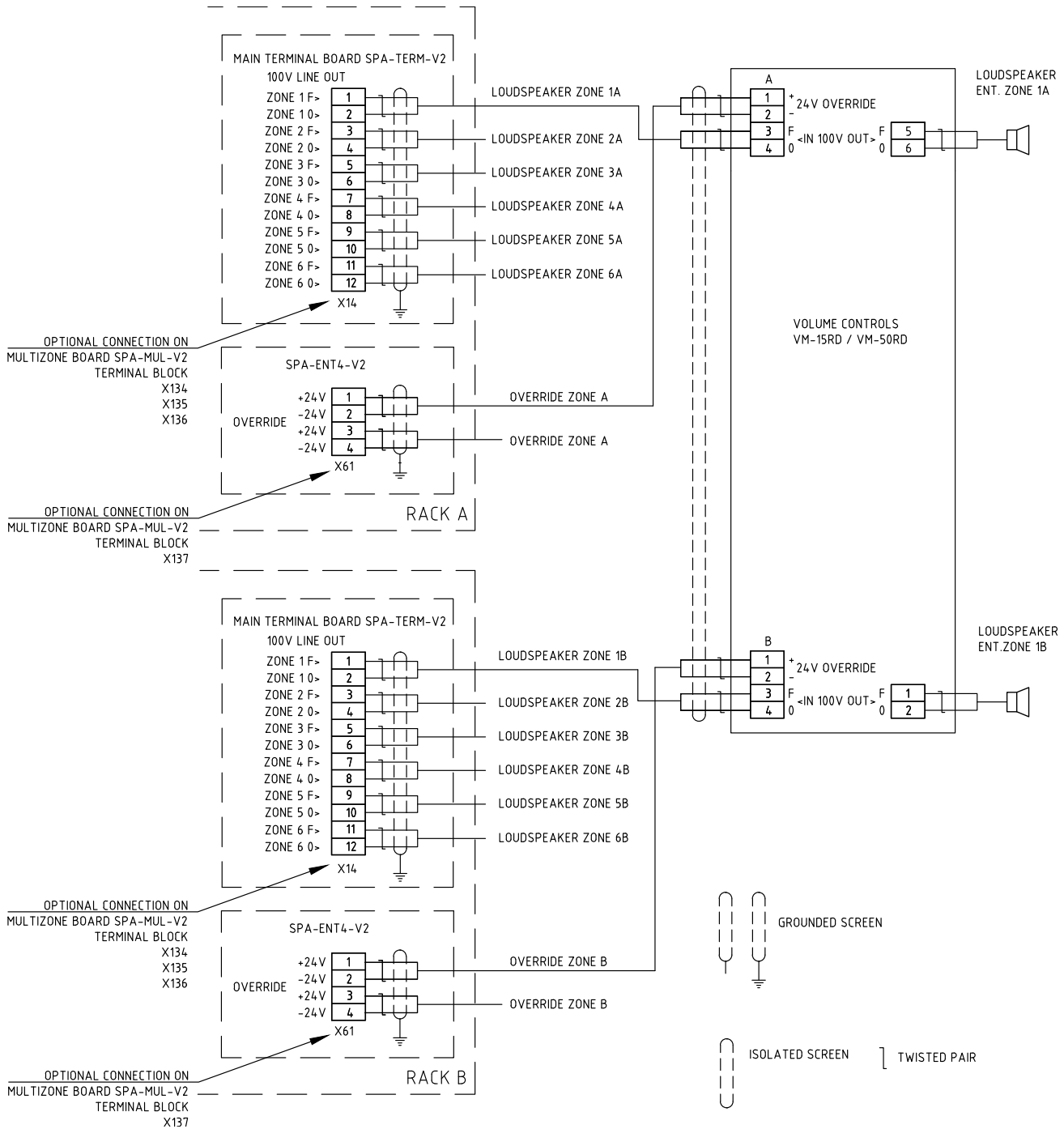

## 2.7.16 Connecting Talk-Back System

The suggested connection below has two options:

- Only emergency call will be announced in talk-back system. Case jumper set in EMS only.
- Emergency PA and PA all-call will be announced in talk-back system. Case jumper set in EMS+PA mode. In this mode you can not connect CIS to the SPA-TERMINALBOARD-V2 X7 (Talk-Back Input).

Note: For jumper settings see section 4.3.6 SPA-EMS-V2 in A100K10369 SPA-V2 System Manual.

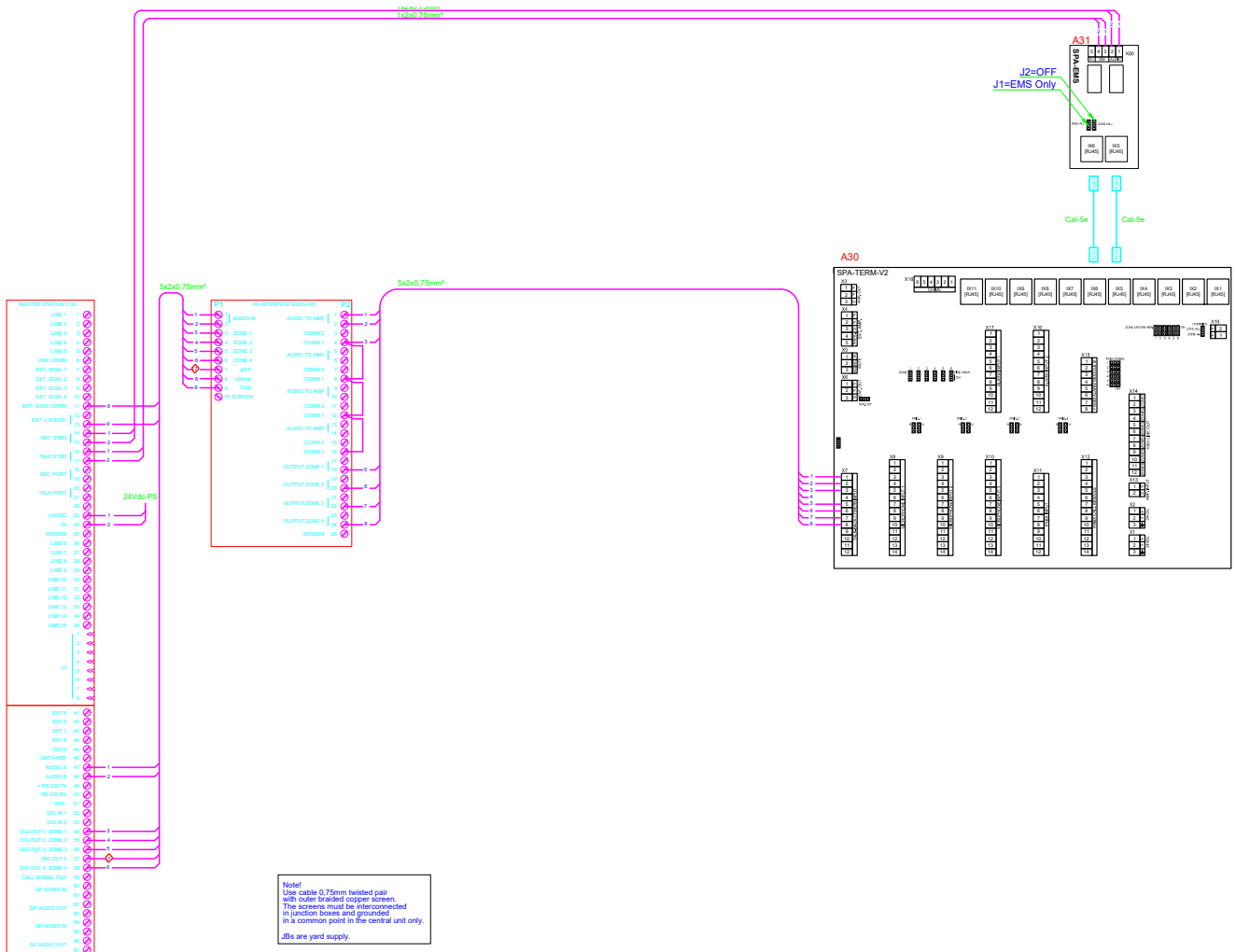

## 2.7.17 Connecting PABX & Entertainment

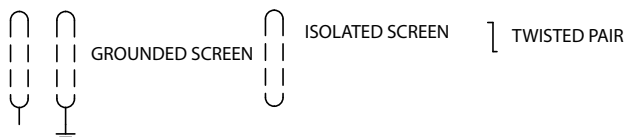
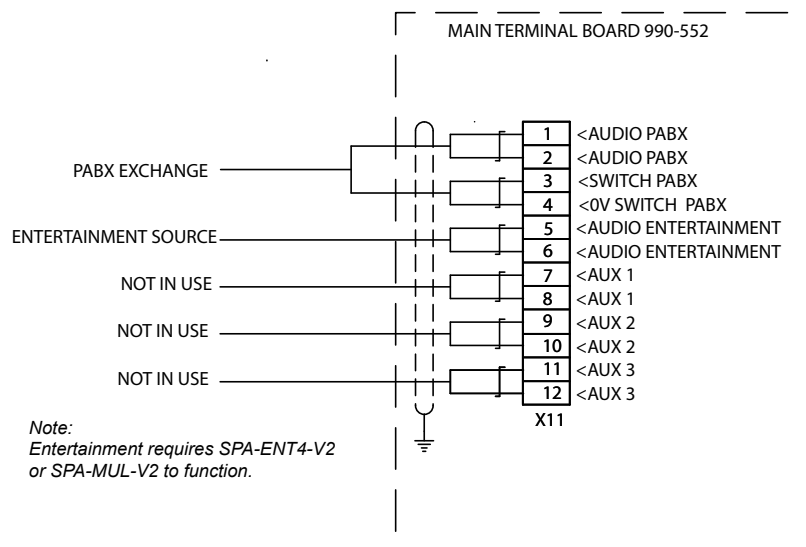

## 2.7.18 Configuration Example 1: Microphone panels, PABX

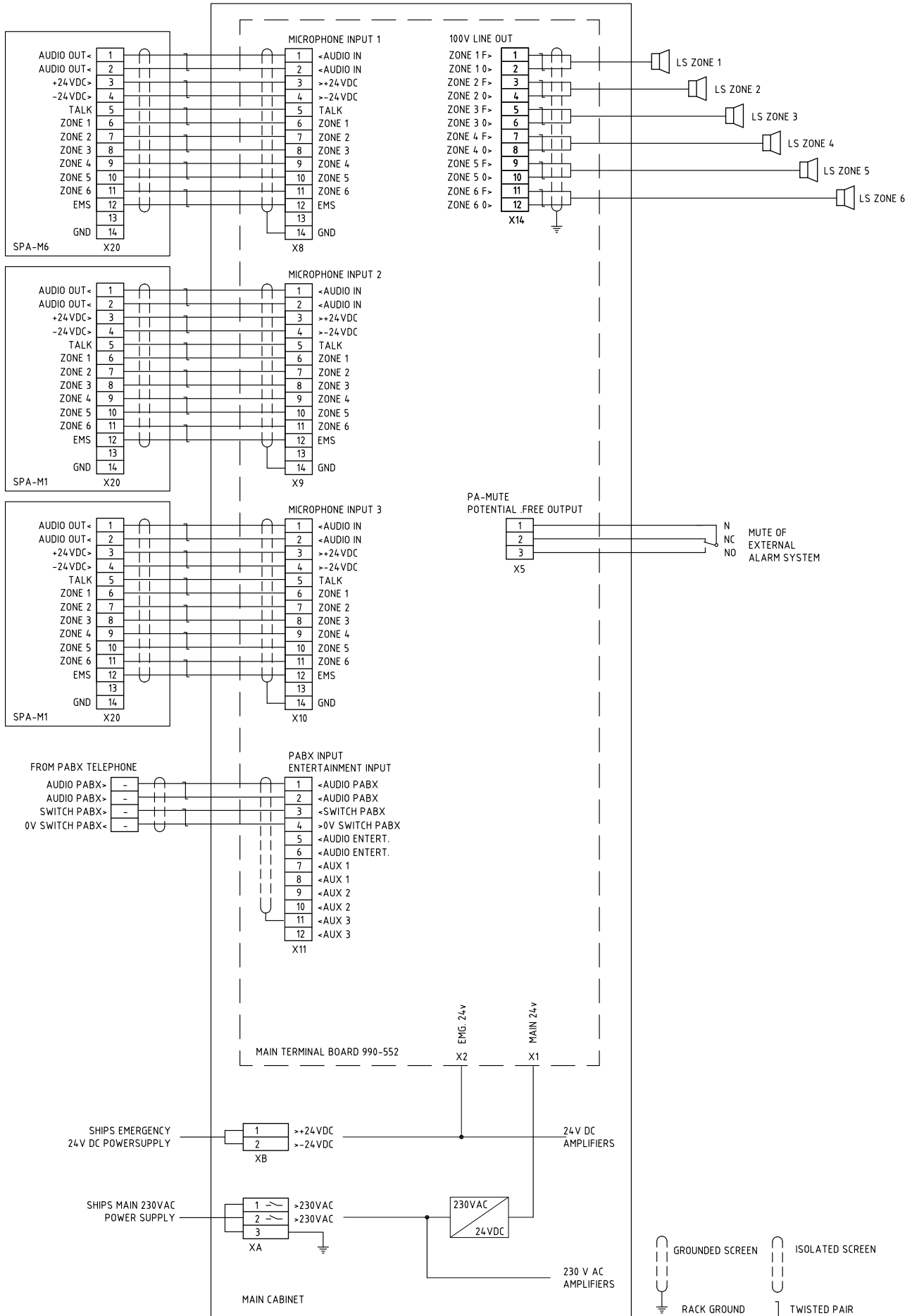

## 2.7.19 Configuration Example 2: Microphone, Alarm Panels, PABX

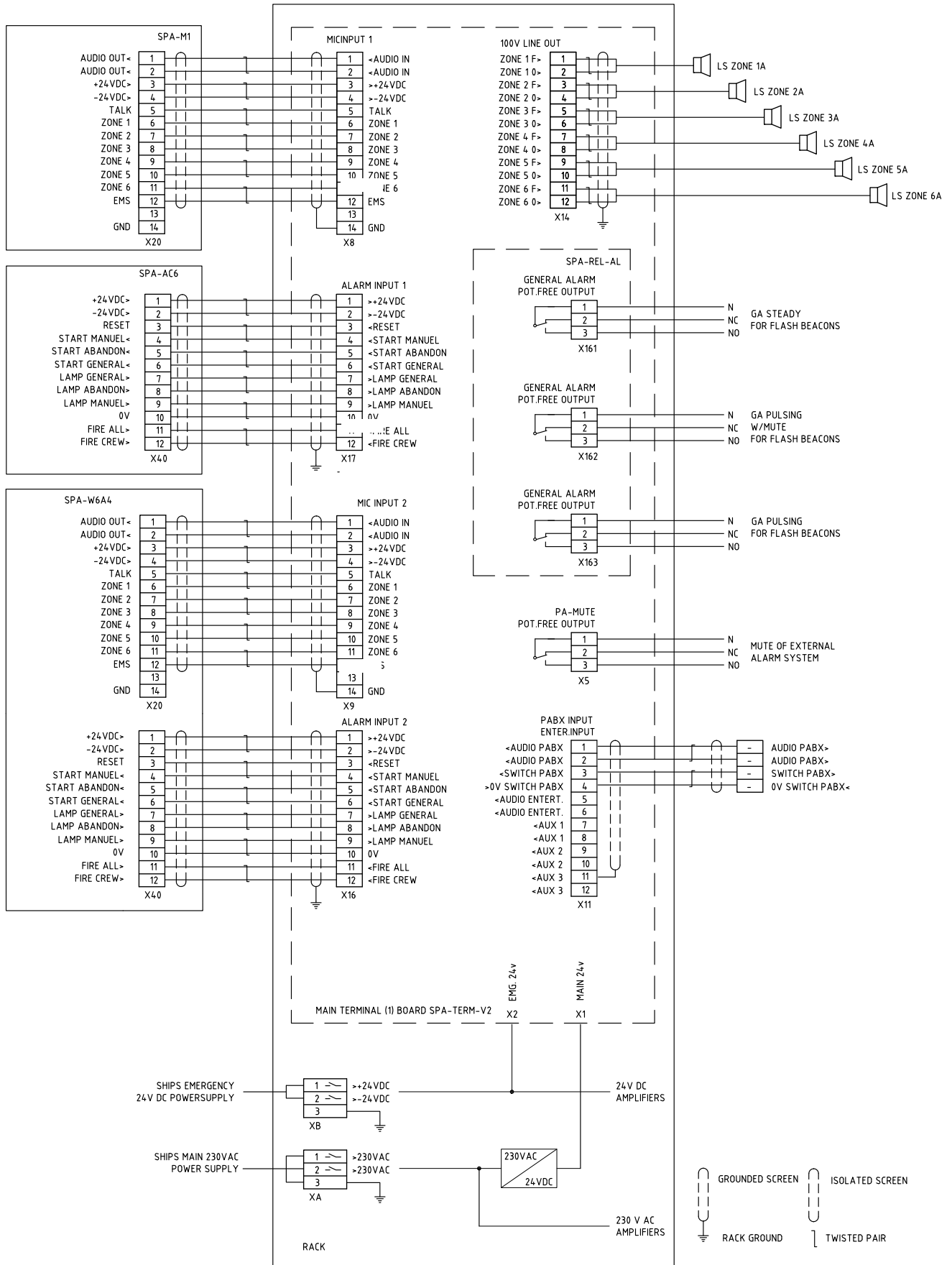

## 2.7.20 Configuration Example 3: Dual PA/GA

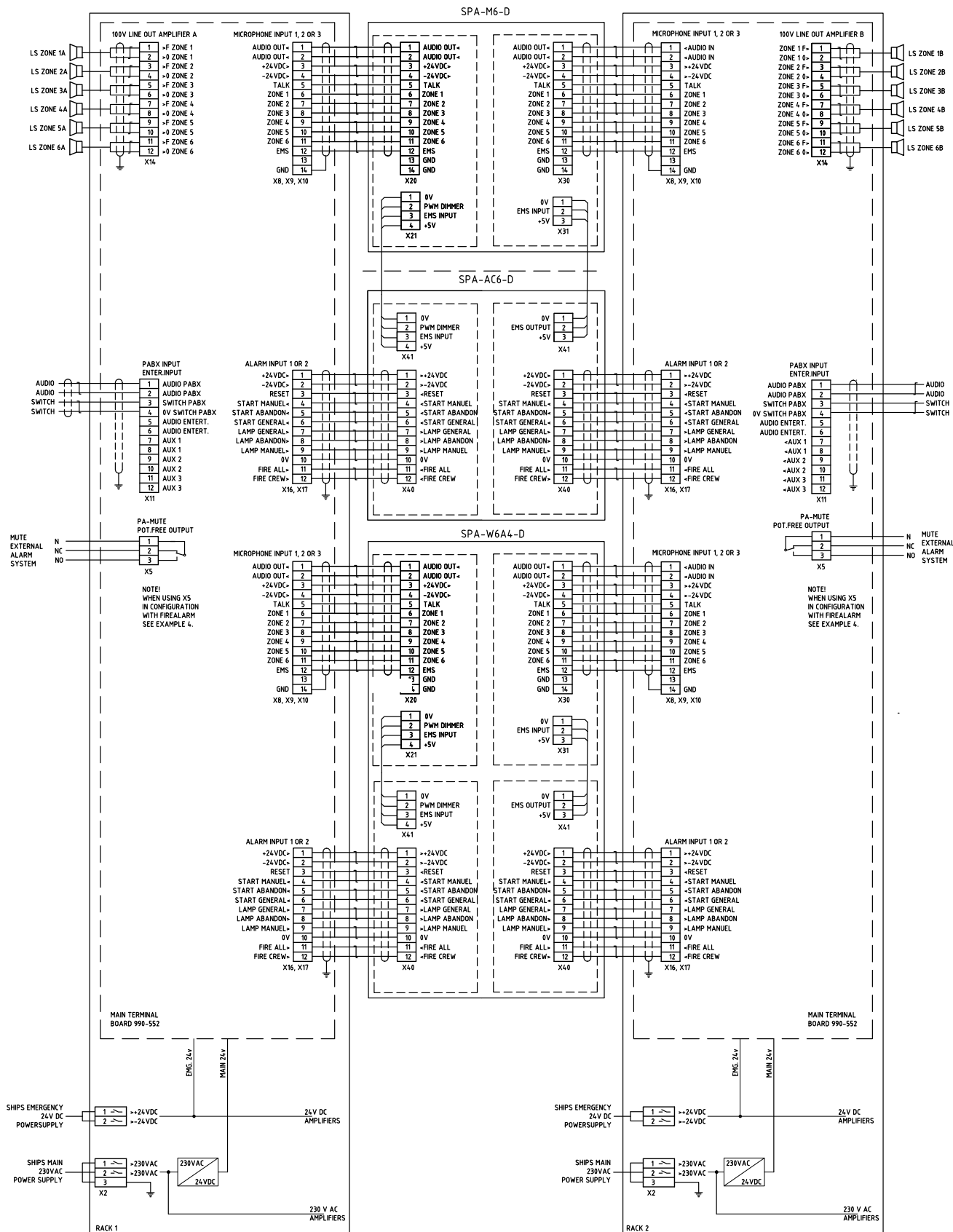

## 2.7.21 Configuration Example 4: Required PA/GA Connection between Racks 1 & 2

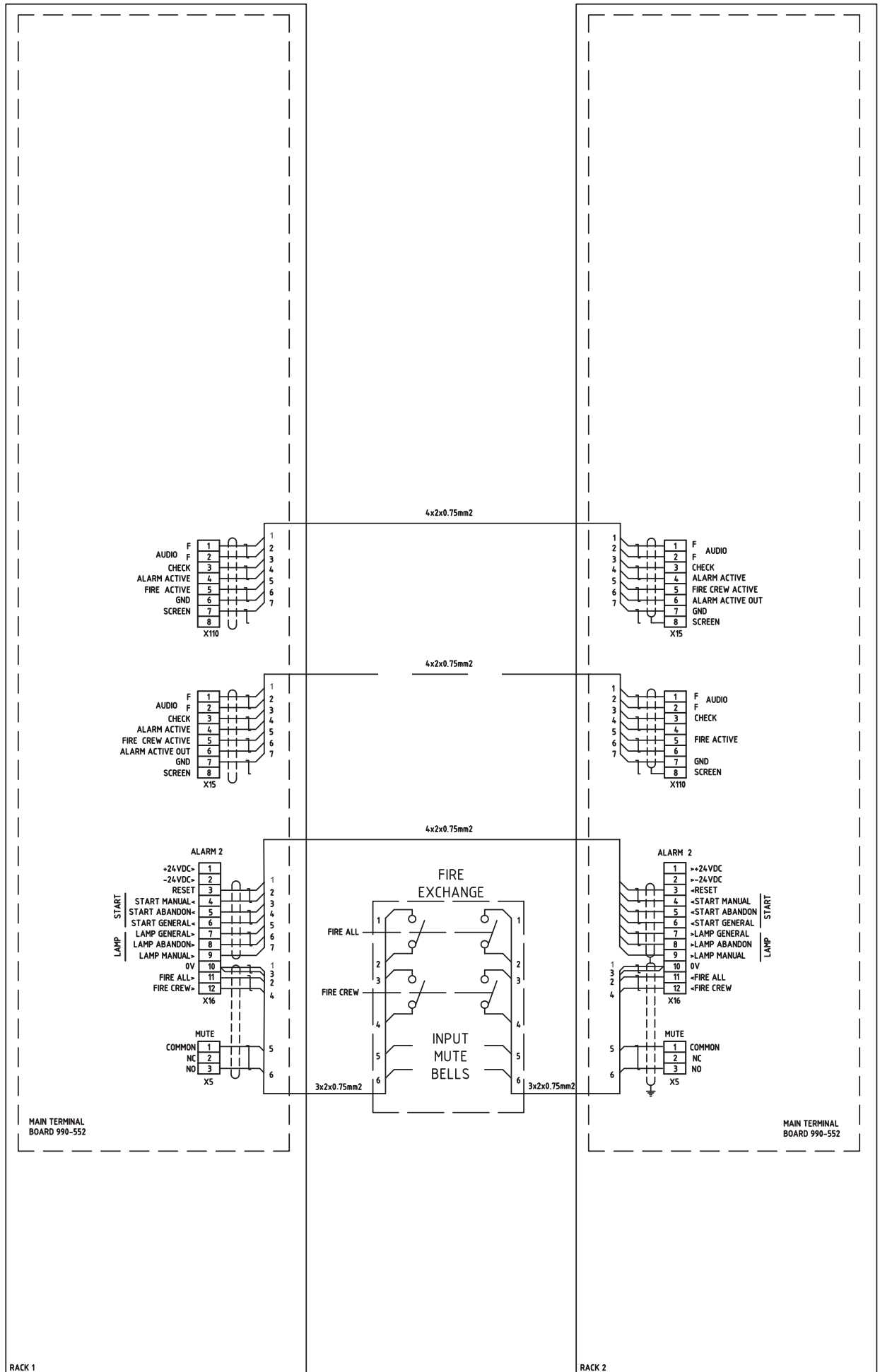

## 2.8 Jumper Settings for Configuration of Functions

The jumpers are normally set according to project specifications at delivery, but may be changed if modifications are required after installation.

### 2.8.1 Jumper settings on SPA Terminal Board

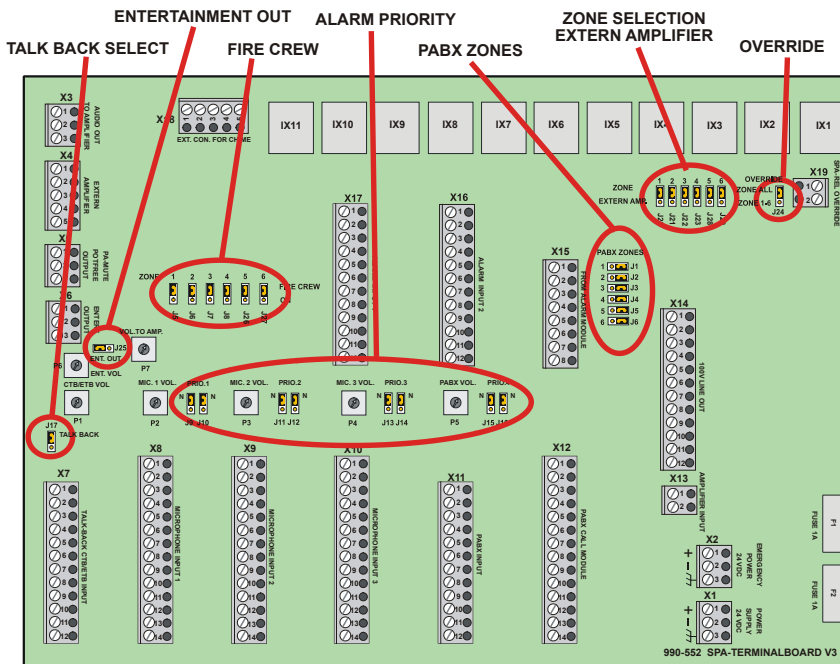

#### Entertainment output selection

Jumper J25 in right position (default setting):



- Entertainment audio on the 'Audio out to amplifiers' terminal X3.
- Entertainment will then have lowest priority and be overridden by any messages and alarms.

Figure 6 Jumper for Entertainment Output to external system

Jumper J25 in left position:

- Entertainment audio on the 'Entertainment output' terminal X6 for connecting to external entertainment system.
- The entertainment program will be present on this terminal independent of other ongoing messages in the system.



#### Audio Input from Talk-Back X7

Jumper J17 in upper position (default setting):

- Audio from the Talk-back unit is connected to minus.
- If audio output 0dB from Talk-Back is connected both to SPA and a 100V Talk-Back system, the Jumper J17 must be set to the lower position.

Figure 7 Jumper for audio from Talk-Back system

#### Alarm Priority

Default setting:

- Jumper PRIO.1, PRIO.2 and PRIO.3 in upper (N) position, and PRIO.4 in lower position.



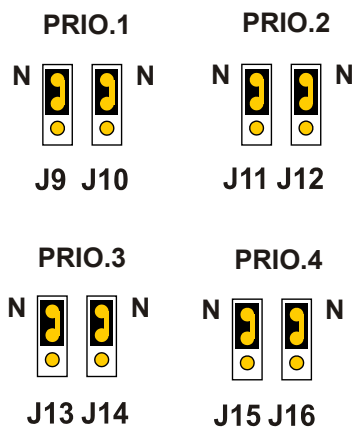

Figure 8 Jumpers for Alarm Priorities

Normal priority: ALARM will have 6<sup>th</sup> priority after Talk-Back, microphones and PABX.

Other priority alarm settings:

ALARM 3<sup>rd</sup> priority after MIC 1:

- Jumper PRIO.1 to lower position and PRIO.4 in upper position.
- PRIO.2 and PRIO.3 in upper (N) position,

ALARM 4<sup>th</sup> priority after MIC 2:

- Jumper PRIO.2 to lower position and PRIO.4 in upper position.
- PRIO.1 and PRIO.3 in upper (N) position.

ALARM 5<sup>th</sup> priority after MIC 3:

- Jumper PRIO.3 to lower position and PRIO.4 in upper position.
- PRIO.1 and PRIO.2 in upper (N) position,

Both jumpers in pair must be set.

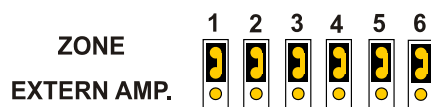

Figure 9 Jumpers for external audio out per zone

**Zone selection for audio out to External Amplifier**

Select the zone(s) by setting the jumper(s) to lower position for activation of audio to 'External amplifier' on terminal X4.

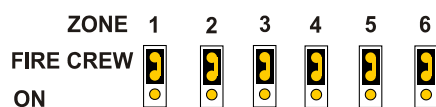

Figure 10 Jumpers for fire crew alarm per zone

**Zone selection to Fire Crew**

Select the zone(s) by setting the jumper(s) to ON for alarm to the fire crew area.

**PABX ZONES**

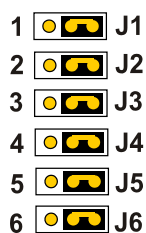

Figure 11 Jumpers for PBX audio output per zone

**Zone selection for PABX**

Default setting: PABX audio to all zones, right position.

If PABX audio shall be distributed to different zones the jumper must be set to the left position.

At least one zone must be selected (ON) if PABX is used.

**2.8.2 Jumper settings on SPA-EMS-V2 board (990-362)**

For audio output to external equipment



**Zone All – Talk-Back Selection**

- Set jumper J2 in left position for ZONE ALL and TALK-BACK on.
- Set jumper J2 in right position for TALK-BACK off



**Emergency selection**

- Set jumper J1 in EMS+ALL position for emergency message with 1<sup>st</sup> priority.
- Set jumper J1 in EMS ONLY position for normal default priority.

Figure 12 Jumpers for Talk-Back with emergency message

### 2.8.3 Volume Control Override

Activation of volume override via three different jumper settings:

- Normal override
  - Zone selection 1 to 6 or only All Call override.
- Emergency override
  - Normal and EMS or EMS ONLY override
- Internal or external 24V DC override

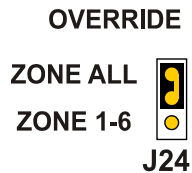

#### **Normal override (on SPA terminal board 990-552)**

Jumper J24 on the main terminal board must be set to ZONE ALL or zone selection (Zone selection is the default.)

Figure 13 Jumpers for override on All Call vs. zones 1-6

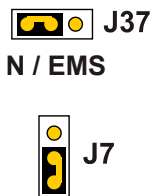

#### **Emergency override on SPA 4-way entertainment 6 zones board (990-363) or SPA multi 4-way entertainment 6 zones board (990-338)**

Jumper J7 on the main 4-way Entertainment board (990-363) or J37 on the SPA-multi 4-way entertainment 6 zones board have to be set to Normal and Emergency or Emergency Only. This setting will override volume control.

The default setting is “only EMS will override volume control”.

Figure 14 Jumpers for override on normal & EMS vs. EMS only

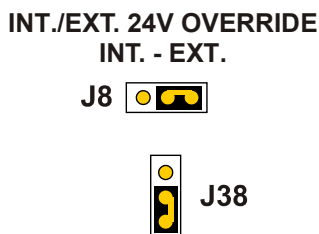

#### **24V DC for override on SPA 4-way entertainment 6 zones board (990-363) or SPA multi 4-way entertainment 6 zones board (990-338)**

Jumper J8 on the main 4-way Entertainment board (990-363) or J38 on the SPA-multi 4-way entertainment 6 zones board have to be set to INT. or EXT.

The default setting is “Internal” override.

Figure 15 Jumpers for override with internal or external 24 VDC

- ① A maximum of 20 volume control units can be connected when the jumper is set to internal.

## 2.8.4 Jumper Settings on 4-Way Entertainment 6 Zones Board (990-363)

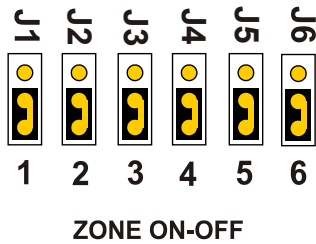

### Entertainment output selection

Set jumpers J1 to J6 to **ON** for Entertainment audio selection for any of the 6 zones. This setting will be overridden by any messages or alarms.

## 2.8.5 Jumper Settings on SPA Multi 4-Way Entertainment 6 Zones Board (990-338)

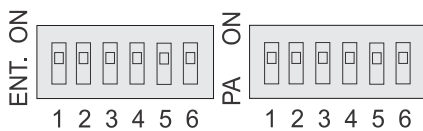

### Entertainment / Public address output selection Zone 1-6A (X131)

Select the entertainment zone(s) 1-6A by DIPSWITCH (X131) to position ON).

Disconnect ENT zone(s) by DIPSWITCH to position ENT

Select the PA zone(s) 1-6A by DIPSWITCH to position ON).

Disconnect ENT zone(s) by DIPSWITCH to position PA

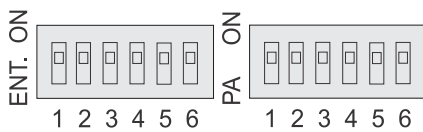

### Entertainment / Public address output selection Zone 1-6B (X132)

Select the entertainment zone(s) 1-6A by DIPSWITCH to position ON).

Disconnect ENT zone(s) by DIPSWITCH to position ENT

Select the PA zone(s) 1-6A by DIPSWITCH to position ON).

Disconnect ENT zone(s) by DIPSWITCH to position PA

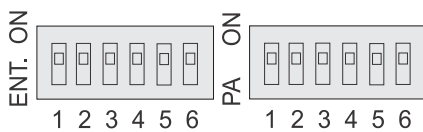

### Entertainment / Public address output selection Zone 1-6C(X133)

Select the entertainment zone(s) 1-6A by DIPSWITCH to position ON).

Disconnect ENT zone(s) by DIPSWITCH to position ENT

Select the PA zone(s) 1-6A by DIPSWITCH to position ON).

Disconnect ENT zone(s) by DIPSWITCH to position PA

## 2.9 Volume Adjustment on SPA Terminal Board

The input signal level for Talk-Back, Microphone panels, PABX, entertainment and amplifiers are normally adjusted according to project specifications at delivery, but may be changed if other signal levels are required after installation.

See location on terminal board for volume controls in section 4.2.4 in the *SPA-V2 System Manual*.

### 2.9.1 Signal Adjustment Talk-Back Input

Trim potentiometer marked P1 CTB/ETB VOL for audio from Talk-Back System on terminal block X7.

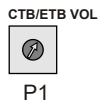

### 2.9.2 Signal Adjustment Microphone Input

Trim potentiometer marked P2 MIC. 1 VOL for audio from Microphone panel 1 on terminal block X8.

Trim potentiometer marked P3 MIC. 2 VOL for audio from Microphone panel 2 on terminal block X9.

Trim potentiometer marked P4 MIC. 3 VOL for audio from Microphone panel 3 on terminal block X10.

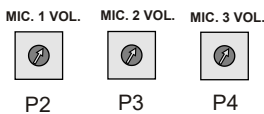

### 2.9.3 Signal Adjustment PABX Input

Trim potentiometer marked P5 PABX VOL for audio input from Automatic Telephone System on terminal block X11, 1-2.



### 2.9.4 Signal Adjustment Entertainment Input

Trim potentiometer marked P6 ENT. VOL for audio input from:

- Internal or external entertainment source on terminal block X11, 5-6.
- Other audio input AUX on terminal block X11, 7-12.



### 2.9.5 Signal Adjustment Amplifier Input

Trim potentiometer marked P7 VOL. TO AMP. for audio output to amplifiers on terminal block X3.



### 2.9.6 Volume Adjustment on Amplifier VPA-120/VPA-240/VPA-400

Trim potentiometer marked CALL for audio input adjustment microphone input 1.

Trim potentiometer marked BGM for audio input adjustment microphone input 2.

Trim potentiometer marked CHIME for adjustment of ding-dong signal level.

Trim potentiometer marked MASTER for adjustment of main audio output.

Trim potentiometer marked BASS/TREBLE for adjustment tone.

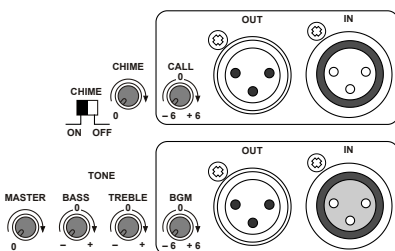



## 2.9.7 Volume Adjustment on Amplifier EA1400/EA1600

Volume adjustment can be done through the potentiometers for Volume, Bass, and Treble.

If the Volume potentiometer is set to the mid-point position and 1V<sub>rms</sub>/1kHz is used as input signal, 100V<sub>rms</sub> should be measured on the "100V" loudspeaker output.

For Volume, the control range is between -14dB and +6dB.

For Bass and Treble, the control range is between 0dB and -10dB.

## 2.10 Loudspeaker Power Consumption

It is important to calculate the total power consumption of the loudspeaker network. The consumption must be adjusted to the system's total amplifier power capacity.

Use the actual installation, project documentation and especially the cable connection diagram as a starting point for the calculation, taking the following into consideration:

- For each zone, count the number of loudspeakers and do the power tapplings in accordance with available output power for the zone.
- Make sure to NOT exceed the total amplifier output capacity.
- Power tapping options can be found in the loudspeaker datasheet.
- The type of Volume Control depends on the number of loudspeakers in a single or A-B system.

## 2.11 Alarm Setup

A DIP switch labeled HEXSW1 is used set all required configurations of alarm tones.

One of fourteen separate alarms can be set using the HEXSW1 switch. For all alarms other than the ABANDON alarm, GENERAL has the highest priority followed by ABANDON and then MANUAL.

① *An example of a custom alarm configuration can be found in Appendix B.*

### 2.11.1 Alarms and Priorities

GENERAL alarm has the highest priority, followed by ABANDON alarm, while MANUAL alarm has the lowest priority. So, if one alarm with lower priority is ongoing and an alarm with higher priority is activated, this alarm will take over and be heard.

### 2.11.2 Possible Configuration of Alarm Relay Boards

The boards are:

- SPA-AL-REL-V2 (one board with 3 relays)
- SPA-AL-REL6-V2 (one board with 6 relays)

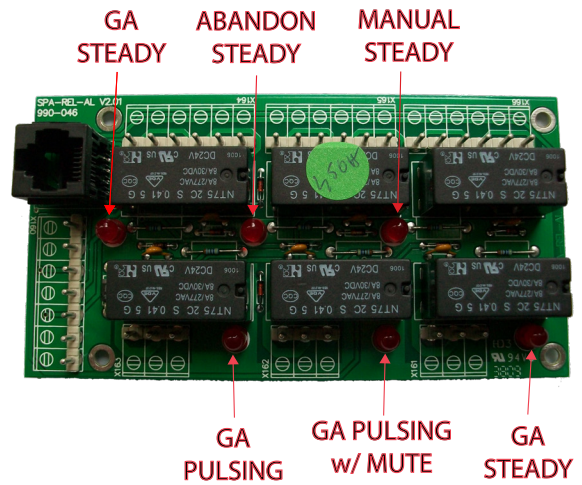
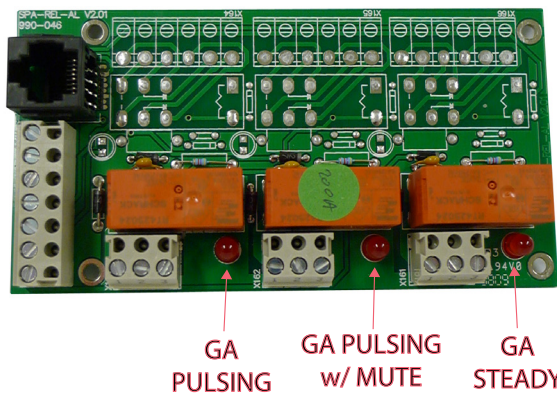

### 2.11.3 Frequency Change on Alarm

The current alarm has 800 Hz frequency.

Change of frequency must be undertaken by Zenitel personnel at customer site or the ship-yard.

The procedure for changing the frequency is:

- Change the value of the register OCR2 of the micro-controller on one of these signal generator cards
  - 3005010124 SPA-EE3-V2 Revision 2.17
  - 3005010121 SPA-EE3D-V2 Revision 2.17
  - 3005010274 SPA-EE3-V2/12 Revision 2.17
  - 3005010122 SPA-EE3D-V2/12V Revision 2.17

① *Illustrations of alarm tone patterns described in the following sections can be found in Appendix C.*

## 2.11.4 Alarm 1

① Refer to the SPA-AL-REL-V2 and SPA-AL-REL6-V2 figures in section 2.11.2 for the location of the LEDs.

Priority	Alarm Type	Audio Sequence	Frequency	"Timing Sequence (sec)"	General LED	Steady LED	Pulsing LED	Pulsing w. Mute LED
1	General	7 short 1/2 long	800Hz	1s Short, 6s Long	Constantly	Constantly	Blinks	Blinks
2	Abandon	Woobling	800/810Hz	Woobling				
3	Manual	Continuous	800Hz	Continuous				
4	NOT IN USE							
5	Fire crew/Fire all	Continuous	800Hz	Continuous				

Abandon LED	Manual LED	MOB LED	SPA-AC6	Activation button	Termination button	Activation type	Contact Output	
			Button 1	Press General	Press General	Toggle	SPA-AL-REL-V2 or SPA-AL-REL6-V2	Pulsing & Steady
constantly			Button 2	Press Abandon	Press Abandon	Toggle	SPA-AL-REL6-V2	Steady
	constantly		Button 3	Press and hold Manual	Release Manual	Latched	SPA-AL-REL6-V2	Steady
			Button 4				N/A	N/A
		constantly	Button 5	Press and hold	Release	Latched	N/A	N/A

The MANUAL button is also used to manually generate alarm tone patterns.

## 2.11.5 Alarm 2

① Refer to the SPA-AL-REL-V2 and SPA-REL-V2 figures in section 2.11.2 for the location of the LEDs.

Priority	Alarm Type	Audio Sequence	Frequency	"Timing Sequence (sec)"	General LED	Steady LED	Pulsing w. Mute LED	Pulsing w. Mute LED
1	General	7 short 1/2 long	800Hz	1s Short, 6s Long	Constantly	Constantly	Blinks	Blinks
2	Abandon	Woobling	800/810Hz	Woobling				
3	Manual	Continuous	800Hz	Continuous				
4	Reset							
5	Fire crew/Fire all	Continuous	800Hz	Continuous				

Abandon LED	Manual LED	MOB LED	SPA-AC6	Activation button	Termination button	Activation type	Contact Output	
			Button 1	Press General	Press Reset	Toggle	SPA-AL-REL-V2 or SPA-AL-REL6-V2	Pulsing & Steady
constantly			Button 2	Press Abandon	Press Reset	Toggle	SPA-AL-REL6-V2	Steady
	constantly		Button 3	Press and hold Manual	Release Manual	Latched	SPA-AL-REL6-V2	Steady
			Button 4	Press	Release	Toggle	N/A	N/A
		constantly	Button 5	Press and hold	Release	Latched	N/A	N/A

## 2.11.6 Alarm 3

① Refer to the SPA-AL-REL-V2 and SPA-REL-V2 figures in section 2.11.2 for the location of the LEDs.

Priority	Alarm Type	Audio Sequence	Frequency	"Timing Sequence (sec)"	General LED	Steady LED	Pulsing w. Mute LED	Pulsing w. Mute LED
1	General	7 short 1/2 long	800Hz	1s Short, 6s Long	constantly	constantly	blinks	blinks
2	Abandon	Continuous	800Hz	Continuous				
3	Manual	Continuous	800Hz	Continuous				
4	MOB	3 x Short	800Hz	1s Short, 3s Long				
5	Fire crew/Fire all	Continuous	800Hz	Continuous				

Abandon LED	Manual LED	MOB LED	SPA-AC6	Activation button	Termination button	Activation type	Contact Output	
			Button 1	Press General	Press General	Toggle	SPA-AL-REL-V2 or SPA-AL-REL6-V2	Pulsing & Steady
constantly			Button 2	Press Abandon	Press Abandon	Toggle	SPA-AL-REL6-V2	Steady
	constantly		Button 3	Press and hold Manual	Release Manual	Latched	SPA-AL-REL6-V2	Steady
		constantly	Button 4	Press and hold	Release MOB	Latched	N/A	N/A
		constantly	Button 5	Press and hold	Release	Latched	N/A	N/A

## 2.11.7 Alarm 4

① Refer to the SPA-AL-REL-V2 and SPA-REL-V2 figures in section 2.11.2 for the location of the LEDs.

Priority	Alarm Type	Audio Sequence	Frequency	"Timing Sequence (sec)"	General LED	Steady LED	Pulsing w. Mute LED	Pulsing w. Mute LED
1	General	7 short 1/2 long	800Hz	1s Short, 6s Long	blinks	constantly	blinks	blinks
2	Abandon	Woobling	800/810Hz	Woobling				
3	Manual	Continuous	800Hz	Continuous				
4	MOB	1 Short, 1 Long	800Hz	1s Short, 3s Long				
5	Fire crew/Fire all	Continuous	800Hz	Continuous				

Abandon LED	Manual LED	MOB LED	SPA-AC6	Activation button	Termination button	Activation type	Contact Output	
			Button 1	Press General	Press General	Toggle	SPA-AL-REL-V2 or SPA-AL-REL6-V2	Pulsing & Steady
constantly			Button 2	Press Abandon	Press Abandon	Toggle	SPA-AL-REL6-V2	Steady
	constantly		Button 3	Press and hold Manual	Release Manual	Latched	SPA-AL-REL6-V2	Steady
		constantly	Button 4	Press and hold	Release MOB	Latched	N/A	N/A
		constantly	Button 5	Press and hold	Release	Latched	N/A	N/A



## 2.11.8 Alarm 5

① Refer to the SPA-AL-REL-V2 and SPA-REL-V2 figures in section 2.11.2 for the location of the LEDs.

Priority	Alarm Type	Audio Sequence	Frequency	"Timing Sequence (sec)"	General LED	Steady LED	Pulsing w. Mute LED	Pulsing w. Mute LED
1	General	7 short 1/2 long	800Hz	1s Short, 6s Long	constantly	constantly	blinks	blinks
2	Abandon	1 short 1 long	800Hz	1s Short, 3 s Long				
3	Manual	Continuous	800Hz	Continuous				
4	MOB	1 x long 1 x short	800Hz	1s Short, 3s Long				
5	Fire crew/Fire all	Continuous	800Hz	Continuous				

Abandon LED	Manual LED	MOB LED	SPA-AC6	Activation button	Termination button	Activation type	Contact Output	
			Button 1	Press General	Press General	Toggle	SPA-AL-REL-V2 or SPA-AL-REL6-V2	Pulsing & Steady
constantly			Button 2	Press Abandon	Press Abandon	Toggle	SPA-AL-REL6-V2	Steady
	constantly		Button 3	Press and hold Manual	Release Manual	Latched	SPA-AL-REL6-V2	Steady
		constantly	Button 4	Press and hold	Release MOB	Latched	N/A	N/A
		constantly	Button 5	Press and hold	Release	Latched	N/A	N/A

## 2.11.9 Alarm 6

① Refer to the SPA-AL-REL-V2 and SPA-REL-V2 figures in section 2.11.2 for the location of the LEDs.

Priority	Alarm Type	Audio Sequence	Frequency	"Timing Sequence (sec)"	General LED	Steady LED	Pulsing w. Mute LED	Pulsing w. Mute LED
1	General	7 short 1/2 long	800Hz	1s Short, 6s Long	constantly	constantly	blinks	blinks
2	Abandon	Wobling	800/810Hz	Wobling				
3	Manual	Continuous	800Hz	Continuous				
4	MOB	1 x long 1 x short	800Hz	1s Short, 3s Long				
5	Fire crew/Fire all	Continuous	800Hz	Continuous				

Abandon LED	Manual LED	MOB LED	SPA-AC6	Activation button	Termination button	Activation type	Contact Output	
			Button 1	Press General	Press General	Toggle	SPA-AL-REL-V2 or SPA-AL-REL6-V2	Pulsing & Steady
constantly			Button 2	Press Abandon	Press Abandon	Toggle	SPA-AL-REL6-V2	Steady
	constantly		Button 3	Press and hold Manual	Release Manual	Latched	SPA-AL-REL6-V2	Steady
		constantly	Button 4	Press and hold	Release MOB	Latched	N/A	N/A
		constantly	Button 5	Press and hold	Release	Latched	N/A	N/A

## 2.11.10 Alarm 7

① Refer to the SPA-AL-REL-V2 and SPA-REL-V2 figures in section 2.11.2 for the location of the LEDs.

Priority	Alarm Type	Audio Sequence	Frequency	"Timing Sequence (sec)"	General LED	Steady LED	Pulsing w. Mute LED	Pulsing w. Mute LED
1	General	7 short 1/2 long	800Hz	1s Short, 6s Long	constantly	constantly	blinks	blinks
2	Abandon	1 short, 1long	800Hz	1s Short, 3s Long				
3	Manual	Continuous	800Hz	Continuous				
4	Reset							
5	Fire crew/Fire all	Continuous	800Hz	Continuous				

Abandon LED	Manual LED	MOB LED	SPA-AC6	Activation button	Termination button	Activation type	Contact Output	
			Button 1	Press General	Press Reset	Toggle	SPA-AL-REL-V2 or SPA-AL-REL6-V2	Pulsing & Steady
constantly			Button 2	Press Abandon	Press Reset	Toggle	SPA-AL-REL6-V2	Steady
	constantly		Button 3	Press and hold Manual	Release Manual	Latched	SPA-AL-REL6-V2	Steady
			Button 4	Press	Release	Toggle	N/A	N/A
		constantly	Button 5	Press and hold	Release	Latched	N/A	N/A

## 2.11.11 Alarm 8

① Refer to the SPA-AL-REL-V2 and SPA-REL-V2 figures in section 2.11.2 for the location of the LEDs.

Priority	Alarm Type	Audio Sequence	Frequency	"Timing Sequence (sec)"	General LED	Steady LED	Pulsing w. Mute LED	Pulsing w. Mute LED
1	General	7 short 1/2 long	800Hz	1s Short, 6s Long	constantly	constantly	blinks	blinks
2	Abandon	Wobling 2	1200Hz/3000H	Wobling2				
3	Manual	Continuous	800Hz	Continuous				
4	Reset							
5	Fire crew/Fire all	Continuous	800Hz	Continuous				

Abandon LED	Manual LED	MOB LED	SPA-AC6	Activation button	Termination button	Activation type	Contact Output	
			Button 1	Press General	Press Reset	Toggle	"SPA-AL-REL-V2 or SPA-AL-REL6-V2"	Pulsing & Steady
constantly			Button 2	Press Abandon	Press Reset	Toggle	SPA-AL-REL6-V2	Steady
	constantly		Button 3	Press and hold Manual	Release Manual	Latched	SPA-AL-REL6-V2	Steady
			Button 4	Press	Release	Toggle	N/A	N/A
		constantly	Button 5	Press and hold	Release	Latched	N/A	N/A

## 2.11.12 Alarm 9

① Refer to the SPA-AL-REL-V2 and SPA-REL-V2 figures in section 2.11.2 for the location of the LEDs.

Priority	Alarm Type	Audio Sequence	Frequency	"Timing Sequence (sec)"	General LED	Steady LED	Pulsing w. Mute LED	Pulsing w. Mute LED
1	General	7 short 1/2 long	800Hz	1s Short, 6s Long	blinks	constantly	blinks	blinks
2	Abandon	1 short, 1long	800Hz	1s Short, 3 s Long				
3	Manual	Continuous	800Hz	Continuous				
4	Reset							
5	Fire crew/Fire all	Continuous	800Hz	Continuous				

Abandon LED	Manual LED	MOB LED	SPA-AC6	Activation button	Termination button	Activation type	Contact Output	
			Button 1	Press General	Press Reset	Toggle	SPA-AL-REL-V2 or SPA-AL-REL6-V2	Pulsing & Steady
constantly			Button 2	Press Abandon	Press Reset	Toggle	SPA-AL-REL6-V2	Steady
	constantly		Button 3	Press and hold Manual	Release Manual	Latched	SPA-AL-REL6-V2	Steady
			Button 4	Press	Release	Toggle	N/A	N/A
		constantly	Button 5	Press and hold	Release	Latched	N/A	N/A

## 2.11.13 Alarm 10

① Refer to the SPA-AL-REL-V2 and SPA-REL-V2 figures in section 2.11.2 for the location of the LEDs.

Priority	Alarm Type	Audio Sequence	Frequency	"Timing Sequence (sec)"	General LED	Steady LED	Pulsing w. Mute LED	Pulsing w. Mute LED
1	General	7 short 1/2 long	800Hz	1s Short, 6s Long	constantly	constantly	blinks	blinks
2	Abandon	Continuous	800Hz	Continuous				
3	Manual	Continuous	800Hz	Continuous				
4	MOB	1 short, 1 long	800HZ	1s Short, 3s Long				
5	Fire crew/Fire all	Continuous	800Hz	Continuous				

Abandon LED	Manual LED	MOB LED	SPA-AC6	Activation button	Termination button	Activation type	Contact Output	
			Button 1	Press General	Press General	Toggle	SPA-AL-REL-V2 or SPA-AL-REL6-V2	Pulsing & Steady
constantly			Button 2	Press Abandon	Press Abandon	Toggle	SPA-AL-REL6-V2	Steady
	constantly		Button 3	Press and hold Manual	Release Manual	Latched	SPA-AL-REL6-V2	Steady
			Button 4	Press and hold	Release	Latched	N/A	N/A
		constantly	Button 5	Press and hold	Release	Latched	N/A	N/A

## 2.11.14 Alarm 11

① Refer to the SPA-AL-REL-V2 and SPA-REL-V2 figures in section 2.11.2 for the location of the LEDs.

Priority	Alarm Type	Audio Sequence	Frequency	"Timing Sequence (sec)"	General LED	Steady LED	Pulsing w. Mute LED	Pulsing w. Mute LED
1	General	7 short 1/2 long	800Hz	1s Short, 6s Long	constantly	constantly	blinks	blinks
2	Abandon	Continuous	800Hz	Continuous				
3	Manual	Continuous	800Hz	Continuous				
4	Reset							
5	Fire crew/Fire all	Continuous	800Hz	Continuous				

Abandon LED	Manual LED	MOB LED	SPA-AC6	Activation button	Termination button	Activation type	Contact Output	
			Button 1	Press General	Press Reset	Toggle	SPA-AL-REL-V2 or SPA-AL-REL6-V2	Pulsing & Steady
constantly			Button 2	Press Abandon	Press Reset	Toggle	SPA-AL-REL6-V2	Steady
	constantly		Button 3	Press and hold Manual	Release Manual	Latched	SPA-AL-REL6-V2	Steady
			Button 4	Press	Release	Toggle	N/A	N/A
		constantly	Button 5	Press and hold	Release	Latched	N/A	N/A

## 2.11.15 Alarm 12

① Refer to the SPA-AL-REL-V2 and SPA-REL-V2 figures in section 2.11.2 for the location of the LEDs.

Priority	Alarm Type	Audio Sequence	Frequency	"Timing Sequence (sec)"	General LED	Steady LED	Pulsing w. Mute LED	Pulsing w. Mute LED
1	General	7 short 1 long	800Hz	1s Short, 6s Long	constantly	constantly	blinks	blinks
2	Abandon	Pulsing	800Hz	250ms				
3	Manual	Wobling 2	1200Hz/3000H	Wobling2				
4	Reset							
5	Fire crew (Note:Fire all N/A)	Continuous	800Hz	Continuous				

Abandon LED	Manual LED	MOB LED	SPA-AC6	Activation button	Termination button	Activation type	Contact Output	
			Button 1	Press General	Press Reset	Toggle	SPA-AL-REL-V2 or SPA-AL-REL6-V2	Pulsing & Steady
constantly			Button 2	Press Abandon	Press Reset	Toggle	SPA-AL-REL6-V2	Steady
	constantly		Button 3	Press and hold Manual	Release Manual	Latched	SPA-AL-REL6-V2	Steady
			Button 4	Press	Release	Toggle	N/A	N/A
		constantly	Button 5	Press and hold	Release	Latched	N/A	N/A

## 2.11.16 Alarm 13

① Refer to the SPA-AL-REL-V2 and SPA-REL-V2 figures in section 2.11.2 for the location of the LEDs.

Priority	Alarm Type	Audio Sequence	Frequency	"Timing Sequence (sec)"	General LED	Steady LED	Pulsing w. Mute LED	Pulsing w. Mute LED
1	General	7 short 1/2 long	800Hz	1s Short, 6s Long	constantly	constantly	blinks	blinks
2	Abandon	Pulsing	600/1500Hz	250ms				
3	Manual	Continuous	800Hz	Continuous				
4	MOB	1 short, 1 long	800HZ	1s Short, 3s Long,				
5	Fire crew/Fire all	Continuous	800Hz	Continuous				

Abandon LED	Manual LED	MOB LED	SPA-AC6	Activation button	Termination button	Activation type	Contact Output	
			Button 1	Press General	Press Reset	Toggle	SPA-AL-REL-V2 or SPA-AL-REL6-V2	Pulsing & Steady
constantly			Button 2	Press Abandon	Press Reset	Toggle	SPA-AL-REL6-V2	Steady
	constantly		Button 3	Press and hold Manual	Release Manual	Latched	SPA-AL-REL6-V2	Steady
			Button 4	Press and hold MOB	Release	Latched	N/A	N/A
		constantly	Button 5	Press and hold	Release	Latched	N/A	N/A

## 2.11.17 Alarm 14

① Refer to the SPA-AL-REL-V2 and SPA-REL-V2 figures in section 2.11.2 for the location of the LEDs.

Priority	Alarm Type	Audio Sequence	Frequency	"Timing Sequence (sec)"	General LED	Steady LED	Pulsing w. Mute LED	Pulsing w. Mute LED
1	General	7 short 1/2 long	800Hz	1s Short, 6s Long	Constantly	Constantly	Blinks	Blinks
2	General2	7 short 1/2 long	800Hz	1s Short, 6s Long				
3	Abandon	Woobling	800/810Hz	Woobling				
4	Manual	Continuous	800Hz	Continuous				
5	Fire crew (Fire All cannot be used)	Continuous	800Hz	Continuous				

General2 LED	Abandon LED	Manual LED	SPA-AC6	Activation button	Termination button	Activation type	Contact Output	
			Button 1	Press General	Press General	Toggle	"SPA-AL-REL-V2 or SPA-AL-REL6-V2"	Pulsing & Steady
Blinks			Button 2	Press General2	Press General2	Toggle	SPA-AL-REL6-V2	Pulsing
	Constantly		Button 3	Press Abandon	Press Abandon	Toggle	SPA-AL-REL6-V2	Steady
		Constantly	Button 4	Press and hold Manual	Release Manual	Latched	N/A	N/A
			Button 5	Press and hold	Release	Latched	N/A	N/A

## 2.11.18 Alarm 15

Priority	Alarm Type	Audio Sequence	Frequency	"Timing Sequence (sec)"	General LED	Steady LED	Pulsing w. Mute LED	Pulsing w. Mute LED
1	General	7 short 1/2 long	800Hz	1s Short, 6s Long	Constantly	Constantly	Blinks	Blinks
2	Abandon	Woobling	800/810Hz	Woobling				
3	Manual	Continuous	800Hz	Continuous				
4	MOB	1 x long, 1 short	800Hz	1s Short, 3s Long				
5								

Abandon LED	Manual LED	MOB LED	SPA-AC6	Activation button	Termination button	Activation type	Contact Output	
				NO	NC	Failsafe	SPA-AL-REL-V2 or SPA-AL-REL6-V2	Pulsing & Steady
Constantly				NO	NC	Failsafe	SPA-AL-REL6-V2	Steady
	Constantly			NO	NC	Failsafe	SPA-AL-REL6-V2	Steady
				NO	NC	Failsafe	N/A	N/A
							N/A	N/A

## 2.11.19 FIRE Alarm

Activate the jumpers / DIP switches J5 ... J8, and J26 and J28.

Press and hold the FIRE button down and the alarm will start.

# 3 Commissioning

---

## 3.1 General

The SPA system and all field equipment have been fully tested prior to delivery. To ensure that everything is in order after installation and configuration of the system, carry out the procedures described in the following sections before using the system.

① See section 2 *Installation & Configuration Procedures*.

## 3.2 Mechanical Inspection

- Check that the cabinet is installed in a secure environment and well fastened to the floor (and wall) in accordance with section 2.6.1
- Check that all field equipment is installed and well fastened in accordance with section 2.6.2
- Check that all equipment in the cabinet is undamaged after installation.
- Check that all field equipment is undamaged after connecting the cables.

## 3.3 Cable Connection Inspection

- Check that all cables are connected in accordance with section 2.7.
- Check that these are signal cables 0.75 mm<sup>2</sup> approved ship cable of type twisted-pair with outer braided copper shield.
- Check that the shields are interconnected in junction boxes (if used) and grounded in ground terminals in the cabinet only.
- Check that the installation cables and glands are well fastened.

## 3.4 Power Supply/Consumption Check

- Check that the power supply is used in accordance with requirements in section 2.5.
- Check that the total power consumption of the speaker network is calculated and adjusted against available amplifier power.

## 3.5 Function Configuration Check

The configuration is normally done according to project specification at delivery but may be changed if modifications are needed after installation. Configuration settings affect functions such as routing and adjusting the audio, determining some priorities, selecting zones, and handling emergency calls.

- Check that jumper settings are set in accordance with section 2.8.1 for the main terminal board.
- Check that jumper settings are set in accordance with section 2.8.2 – 2.8.5 for additional function boards.
- Check that the volume for audio input is adjusted in accordance with section 2.9

### 3.6 Startup Procedure

Power switching is provided by external power equipment.

The following procedure has to be completed before the system can be used.

Carry out the start-up and test procedure for all functions and equipment in the installation.

Step	Requirements		
1	<b>Inspection of the following according to section 2.1 - 2.5 :</b> <ul style="list-style-type: none"> <li>- Mechanical</li> <li>- Cable</li> <li>- Power</li> <li>- Function configurations</li> </ul>		
2	<b>System operates on 230V AC main and 24V DC emergency</b> <ul style="list-style-type: none"> <li>- Switch on the 230V main power supply and check that we have 24V DC on terminal X1 on the main terminal board.</li> <li>- Switch on the 24V DC emergency and check that we have 24V DC on terminals X2 on the main terminal board.</li> </ul> <b>Power failure output - SPA-FAIL</b> <ul style="list-style-type: none"> <li>- Switch off the 230V AC main and check that the power failure output is activated when the system operates on 24V DC Emergency</li> </ul>		
3	<b>System operates on 230V AC main and 230V AC Emergency/UPS</b> <ul style="list-style-type: none"> <li>- Switch on the 230V main power supply and check that we have 24V DC on terminal X1 on the main terminal board.</li> <li>- Switch off the 230V AC mains and check that the power failure output is activated when the system operates on 230V AC Emergency/UPS.</li> </ul>		
4	<table border="0" style="width: 100%;"> <tr> <td style="width: 50%; vertical-align: top;"> <b>Switch ON amplifier - Type VPA</b> <ul style="list-style-type: none"> <li>- Switch marked "ON/OFF" and light marked "POWER"</li> <li>- If the LED marked "OVERLOAD" turns red</li> </ul> <p>① <i>If other adjustments or settings are required, the amplifiers must be taken out of the cabinet for access to the controls at rear side.</i></p> <p>The factory settings are:</p> <ul style="list-style-type: none"> <li>- MASTER VOLUME to approximately 80%</li> <li>- BASS and TREBLE to "0" position</li> <li>- BMG to "0" position</li> <li>- Chime OFF Chime volume "0"</li> </ul> </td> <td style="width: 50%; vertical-align: top;"> <b>Switch ON amplifier - Type EA1400/EA1600</b> <ul style="list-style-type: none"> <li>- Check that the Power LED is lit</li> <li>- Fault and Line Error LEDs may blink shortly at the start but it should not be lit continuously</li> <li>- None of the VU meter LEDs should be lit</li> </ul> </td> </tr> </table>	<b>Switch ON amplifier - Type VPA</b> <ul style="list-style-type: none"> <li>- Switch marked "ON/OFF" and light marked "POWER"</li> <li>- If the LED marked "OVERLOAD" turns red</li> </ul> <p>① <i>If other adjustments or settings are required, the amplifiers must be taken out of the cabinet for access to the controls at rear side.</i></p> <p>The factory settings are:</p> <ul style="list-style-type: none"> <li>- MASTER VOLUME to approximately 80%</li> <li>- BASS and TREBLE to "0" position</li> <li>- BMG to "0" position</li> <li>- Chime OFF Chime volume "0"</li> </ul>	<b>Switch ON amplifier - Type EA1400/EA1600</b> <ul style="list-style-type: none"> <li>- Check that the Power LED is lit</li> <li>- Fault and Line Error LEDs may blink shortly at the start but it should not be lit continuously</li> <li>- None of the VU meter LEDs should be lit</li> </ul>
<b>Switch ON amplifier - Type VPA</b> <ul style="list-style-type: none"> <li>- Switch marked "ON/OFF" and light marked "POWER"</li> <li>- If the LED marked "OVERLOAD" turns red</li> </ul> <p>① <i>If other adjustments or settings are required, the amplifiers must be taken out of the cabinet for access to the controls at rear side.</i></p> <p>The factory settings are:</p> <ul style="list-style-type: none"> <li>- MASTER VOLUME to approximately 80%</li> <li>- BASS and TREBLE to "0" position</li> <li>- BMG to "0" position</li> <li>- Chime OFF Chime volume "0"</li> </ul>	<b>Switch ON amplifier - Type EA1400/EA1600</b> <ul style="list-style-type: none"> <li>- Check that the Power LED is lit</li> <li>- Fault and Line Error LEDs may blink shortly at the start but it should not be lit continuously</li> <li>- None of the VU meter LEDs should be lit</li> </ul>		
<b>All system and functional equipment in a standard SPA system is now powered up and ready for use.</b>			
5	<b>Input from 3x Mic Input – X8, X9 and X10 main terminal board</b> <ul style="list-style-type: none"> <li>- Zone 1 to 6 and "ALL CALL"</li> <li>- Priority between the microphone panels</li> <li>- EMS – Emergency PA messages</li> <li>- EMS can only be activated from the Alarm panels SPA-AC6 and SPA-W6A4</li> <li>- Audio from PA panels is 0db (0.7 VAC) signal and can be decreased by operating the potentiometer P2, P3 and P4 on the main terminal board.</li> <li>- Bass and discant tone can be changed by operating the potentiometer on the main PA panel</li> </ul> <b>Do this test for all PA panels.</b>		
6	<b>Input from PABX X11 main terminal board</b> <ul style="list-style-type: none"> <li>- Input from PABX has to be 0db signal and one potential-free contact.</li> <li>- Zone selections from PABX give standard "ALL CALL".</li> <li>- Can be changed by setting Zone jumpers to required zones. When used with SMIII-PA, an analog trunk line will apply.</li> </ul>		
7	<b>Mute of external alarm when PA messages is active.</b> <ul style="list-style-type: none"> <li>- Potential-free output signal N, NC, NO on terminals X5 on main terminal board.</li> </ul>		
8	<b>SPA-EE3-V2 alarm generator (first)</b> <ul style="list-style-type: none"> <li>- Start alarms from Alarm panels – X16/17</li> <li>- GA</li> <li>- Abandon</li> <li>- Manual/Fire</li> <li>- Reset Alarms</li> <li>- Start Fire All and Crew/Engine – X16/17</li> <li>- All zones</li> <li>- Select zones by setting jumpers J5, J6, J7, J8, J26, J27 to required zones</li> <li>- Select required PROM setup according to section 2.11 by operating the PROM selector on the EE3 board</li> <li>- Test that PA mutes alarms</li> </ul>		



9	<p><b>SPA-EE3D-V2 alarm generator (second)</b></p> <ul style="list-style-type: none"> <li>- Start alarms from Alarm panels – X16/17</li> <li>- GA</li> <li>- Abandon</li> <li>- Manual/Fire</li> <li>- Reset Alarms</li> <li>- Start Fire All and Crew / Engine Room – X16/17</li> <li>- All zones</li> <li>- Select zones by setting jumper J5 to required zones</li> <li>- Select required PROM setup according to section 2.11 by operating the PROM selector on the EE3 board</li> <li>- Test that PA mutes alarms</li> <li>- Test the main and standby function by disconnecting the 1x8 RJ45 plug on main Alarm generator. The LED on main generator will change from blinking to steady and the standby alarm generator will start to blink. This indicates that the standby alarm generator is active.</li> </ul>
10	<p><b>Priority Input</b></p> <p>Test that the system has the following priorities:</p> <ul style="list-style-type: none"> <li>- Talk-Back: 1<sup>st</sup> priority</li> <li>- Mic Panels: 2<sup>nd</sup> to 4<sup>th</sup> priority.</li> <li>- PABX: 5<sup>th</sup> priority.</li> <li>- Alarm: 6<sup>th</sup> priority</li> <li>- Entertainment: 7<sup>th</sup> priority</li> </ul> <p>Alarm priority can be changed by setting the jumpers J9 to J16 on main terminal board. Alarm has ____ priority.</p>
11	<p><b>100 V Speaker output on the main terminal board X14</b></p> <p>Test that we have 100V AC Speaker output up to 6 x Zone relay. Use an impedance meter for measuring speaker load. Maximum load connected to the different amplifiers:</p> <ul style="list-style-type: none"> <li>- 83 ohm – 120 W amplifiers</li> <li>- 42 ohm – 240 W amplifiers</li> <li>- 25 ohm – 400 W amplifiers</li> </ul>
12	<p><b>100 V Speaker output on SPA multi zone board - SPA-MUL-V2</b></p> <p>Test that we have 100V speaker audio output up to 3 x (6 x Zone relay). Maximum load connected to the different amplifiers:</p> <ul style="list-style-type: none"> <li>- 83 ohm – 120 W amplifiers</li> <li>- 42 ohm – 240 W amplifiers</li> <li>- 25 ohm – 400 W amplifiers</li> </ul>
13	<p><b>Make a PA message from a Talk-Back panel</b></p> <p>Follow instructions in the <i>SPA-V2 User Manual</i>, section 2.10</p> <p>① <i>If other signal levels are required after installation, adjust the signal by using trimming potentiometer marked P1 CTB/ETB VOL for audio from Talk-Back System on main terminal board, block X7</i></p>
<b>Additional function boards for the SPA system</b>	
14	<p><b>Ding-dong chime generation - SPA-CHIME-V2</b></p> <p>This multiple chime generator has a setting for tone.</p> <ul style="list-style-type: none"> <li>- Set the required tone by operating the potentiometer for tone selection.</li> <li>- Set the tone level to 40 VAC by operating the potentiometer for volume setting.</li> </ul>
15	<p><b>Start entertainment unit - SPA-RCD</b></p> <ul style="list-style-type: none"> <li>- Switch on “ENTERTAINMENT ON/OFF”</li> <li>- Follow user instructions for delivered model.</li> </ul>
16	<p><b>Start Entertainment monitor/control unit - SPA-SWITCH-V2</b></p> <p>This unit has an adjustable preamplifier.</p> <ul style="list-style-type: none"> <li>- For system with entertainment sources such as SPA-RCD6, SPA FM/AM</li> <li>- Follow instructions in the <i>SPA-V2 User Manual</i>.</li> </ul>
17	<p><b>Interface to external system – SPA-EMS-V2</b></p> <p>Additional terminal board for interface Emergency PA and alarm to external system set by jumpers.</p> <ul style="list-style-type: none"> <li>- Test that only EMS and Alarm activate Emergency output signal 0 dB and potential-free contact to external system J1 – X80</li> <li>- Test that EMS and ALL CALL, and alarm activate Emergency output signal 0 dB and potential-free contact to external system J1 – X80</li> </ul>
18	<p><b>Make a PA message using digital message recorder unit combined with remote panel SPA-REM7</b></p> <ul style="list-style-type: none"> <li>- See separate instructions for digital message recorder unit</li> </ul>
19	<p><b>Test of 4-way volume control function (Override) - use board SPA-MUL-V2</b></p> <p>Follow instructions in the <i>SPA-V2 User Manual</i>. Volume Override can be changed via jumper settings:</p> <ul style="list-style-type: none"> <li>- PA override by zone selection or only “All Call” is set with jumper J24 on the main terminal board</li> <li>- For EMS or PA and EMS <b>ONLY</b> volume control override is set with jumpers J37/J7 on the SPA-MUL-V2 / SPA-ENT4-V2 board</li> </ul>

# 4 Appendix A: Local Mute

Local mute is used for instances where feedback is caused by close proximity between a PA panel and a loudspeaker.

To prevent the feedback loop from occurring when making a PA call, the local speaker or speaker loop is disconnected.

Under normal circumstances, the speaker loop is connected via a relay box that defaults to a closed loop to the affected speaker(s).

The PA panel has a local mute output that is connected to the coil of the relay. This triggers when only this panel is activated, giving an active 24VDC out, which breaks the audio going to the local speaker(s). Local mute outputs are limited to 50mA. Our recommended relay box, IRR-3 V1, consumes ~20mA, leaving 30mA for power loss in cable used. We estimate a maximum of 10 meters based on the average 0.75mm<sup>2</sup> power loss.

If you are using a different relay, maximum cable length must be calculated based on cable specifications and remaining current available after relay consumption.

**Warning:** Do not exceed 50mA for the cable and relay as this will cause the system to become unstable.

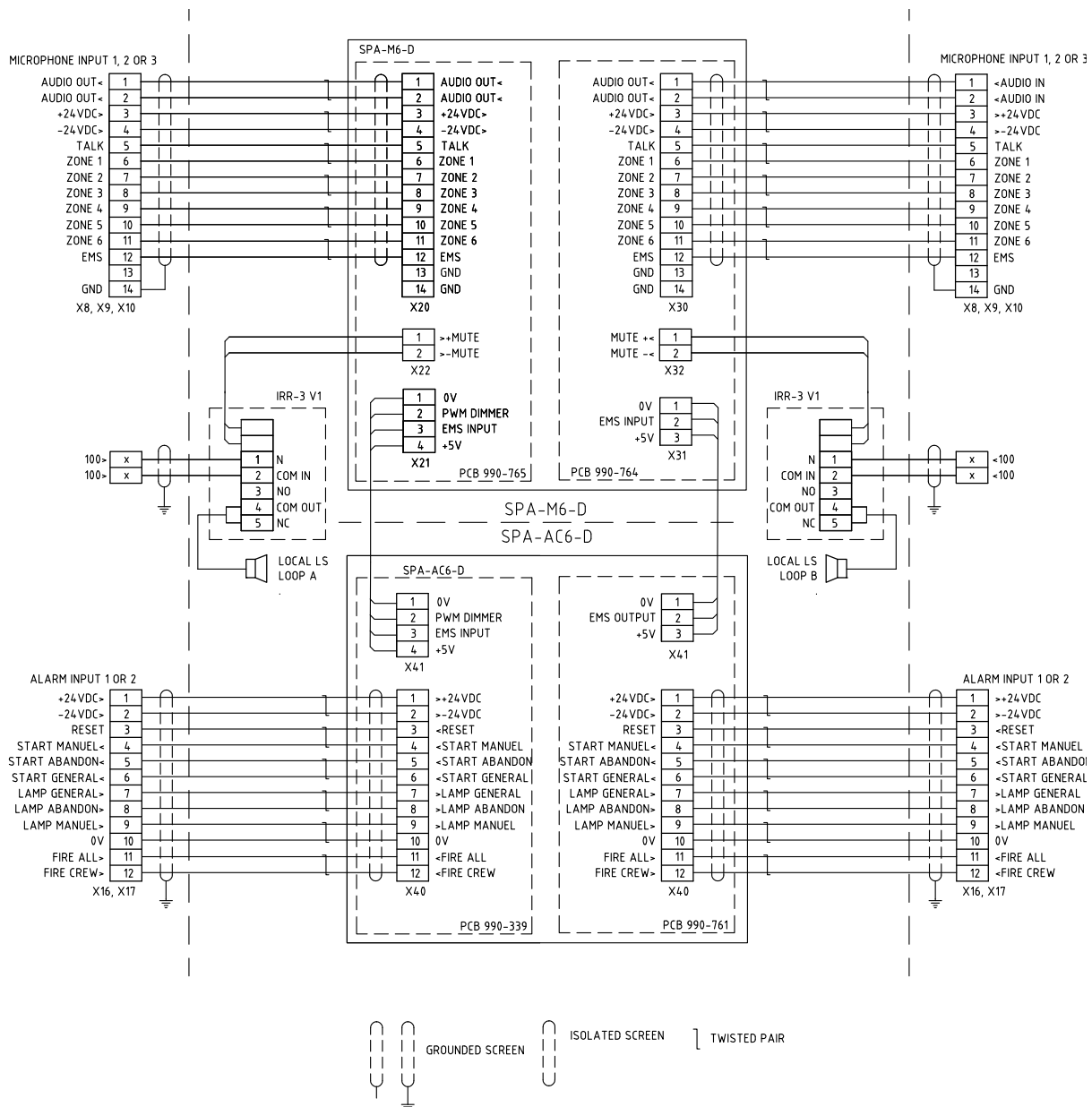

Figure 16 Alarm/Mic Panel with Local Mute for Dual System

## 5 Appendix B: Custom Alarm Configuration Example

The configuration example shown below is for a standard 4002 Alarm.

This is an example configuration of the standard 4002 alarm.																	
Button 1		Activation type	Type	Priority	Pulsing	Alarm Name											
		Toggle	Alarm	1	ON	General											
Tone configuration																	
Time [s]	1	1	1	1	1	1	1	1	1	1	1	1	1	1	3	3	REPEAT
Freq [Hz]	800	0	800	0	800	0	800	0	800	0	800	0	800	0	800	0	REPEAT
Button 2		Activation type	Type	Priority	Pulsing	Alarm Name											
		Toggle	Alarm	2	OFF	Abandon											
Tone configuration																	
Time [s]	0.166	0.166	REPEAT														
Freq [Hz]	800	810	REPEAT														
Button 3		Activation type	Type	Priority	Pulsing	Alarm Name											
		Latched	Alarm	3	OFF	Manual											
Tone configuration																	
Time [s]	1	REPEAT															
Freq [Hz]	800	REPEAT															
Button 4		Activation type	Type	Priority	Pulsing	Alarm Name											
		Toggle	Reset		OFF	RESET											
Tone configuration																	
Time [s]																	
Freq [Hz]																	
Button 5		Activation type	Type	Priority	Pulsing	Alarm Name											
		Latched	Alarm	4	ON	Fire											
Tone configuration																	
Time [s]	1	REPEAT															
Freq [Hz]	800	REPEAT															

# 6 Appendix C: Alarm Tone Pattern

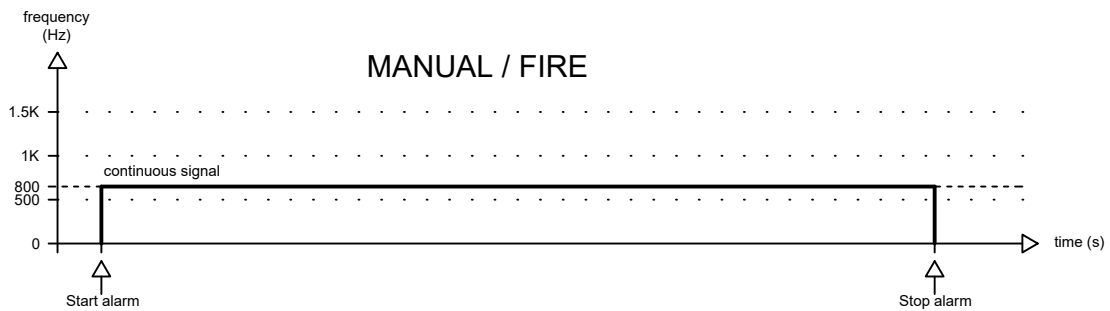
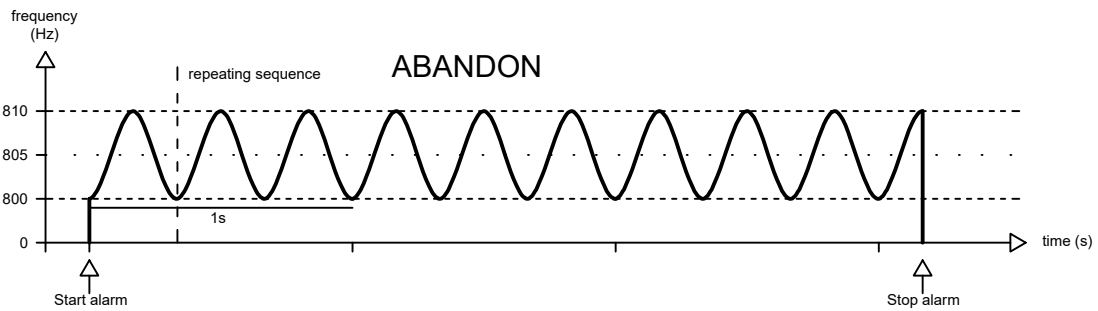
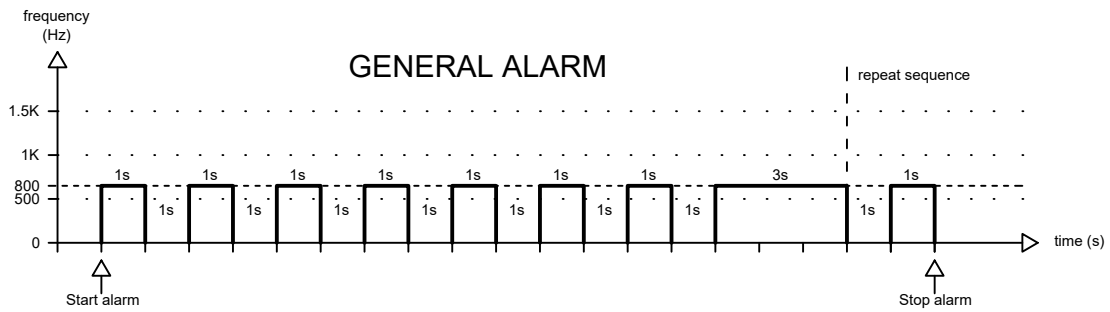
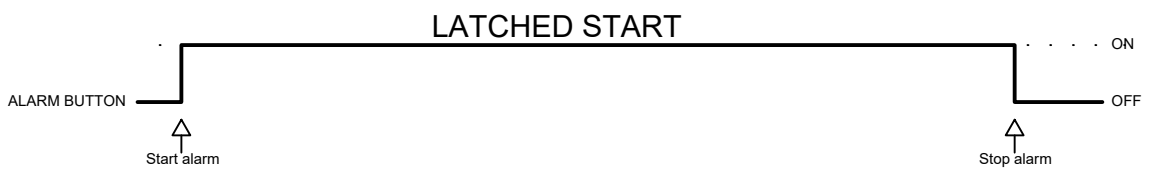
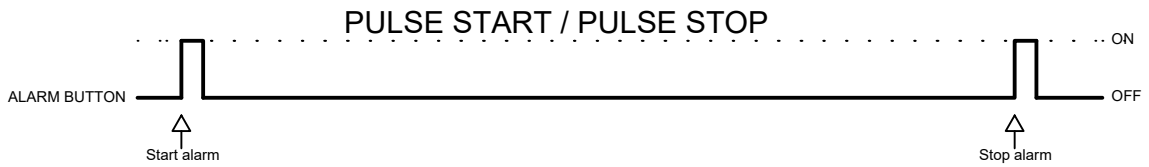
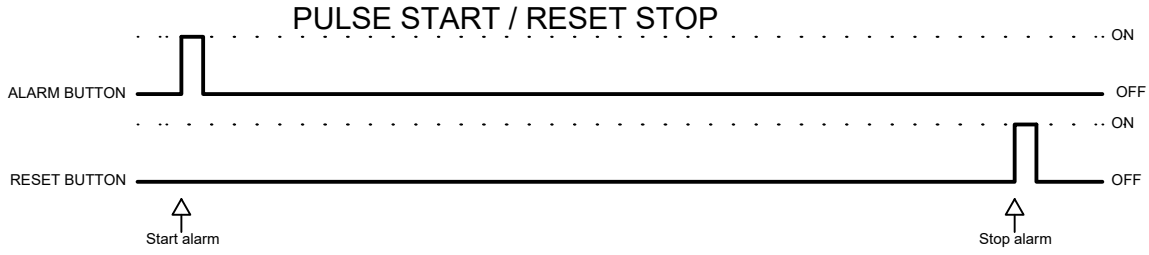

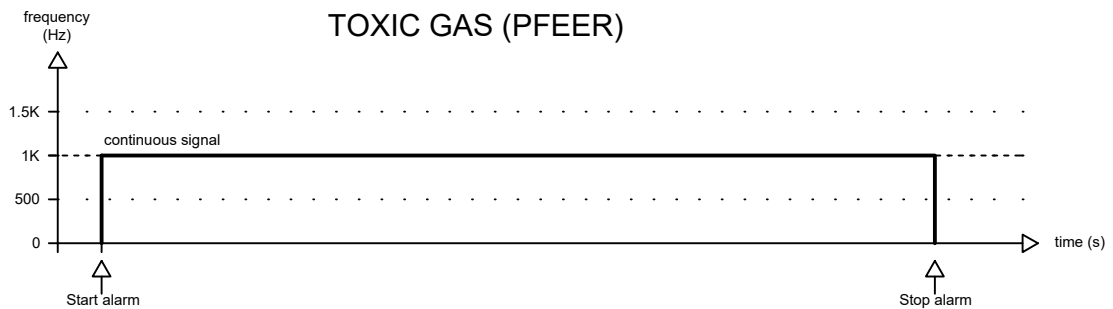
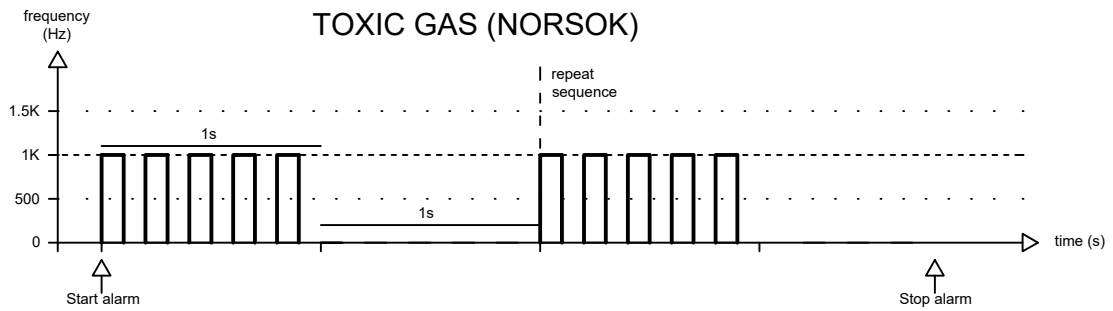
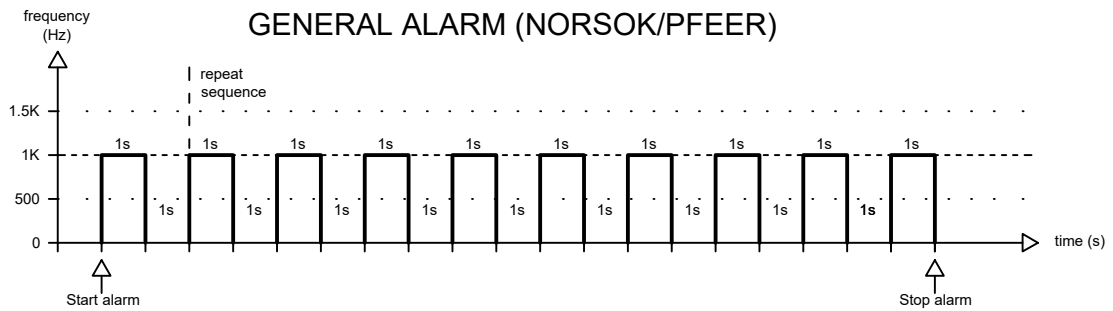
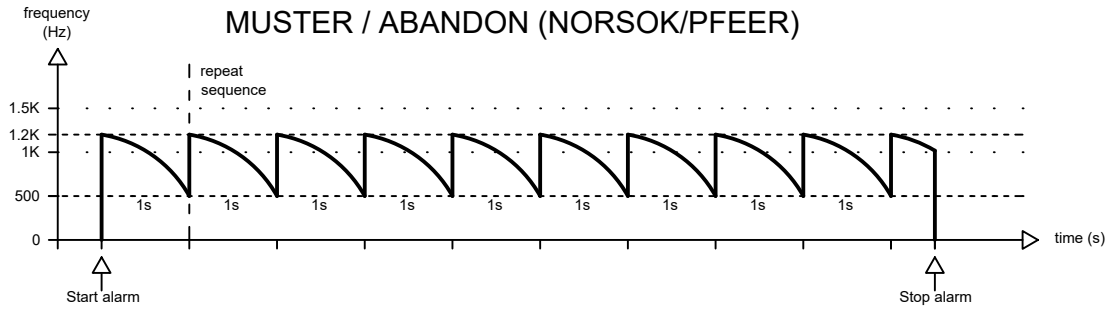
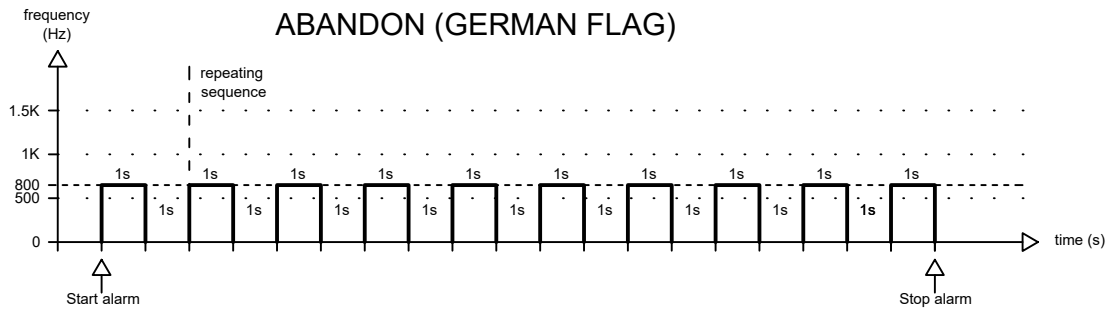



**The WEEE Directive does not legislate that Zenitel, as a 'producer', shall collect 'end of life' WEEE.**

**This 'end of life' WEEE should be recycled appropriately by the owner who should use proper treatment and recycling measures. It should not be disposed to landfill.**

Many electrical items that we throw away can be repaired or recycled. Recycling items helps to save our natural finite resources and also reduces the environmental and health risks associated with sending electrical goods to landfill.



Under the WEEE Regulations, all new electrical goods should now be marked with the crossed-out wheeled bin symbol shown.

Goods are marked with this symbol to show that they were produced after 13<sup>th</sup> August 2005, and should be disposed of separately from normal household waste so that they can be recycled.