

Command Talk-Back & Public Address System



ETB-5 / ETB-10 / ETB-10A / ETB-100 / ETB-100A



About this Document

Document Scope

This document is intended for qualified technicians who will install and commission the ETB-5/ETB-10/ETB-10A/ETB-100/ETB-100A Command Talk-Back & Public Address system on marine vessels. It also provides the end-user with all necessary instructions for operating the ETB central unit.

The following central units (panel version 8.0) are available for the ETB system:

Product	Item Number
ETB-5 Central Unit, Panel Mounted, 5 Lines	3005020022
ETB-10 Central Unit, Panel Mounted, 10 Lines	3005020018
ETB-10A Central Unit, Panel Mounted, Public Address, 10 Lines	3005020021
ETB-100 Central Unit, Panel Mounted, 10 Lines	3005020019
ETB-100A Central Unit, Panel Mounted, Public Address, 10 Lines	3005020020

Publication Log

Rev.	Date	Author	Description
1.0	21.11.2011	HKL	Panel version 8.0 Supersedes installation manuals for ETB-5/ETB-10 (A100K10868) and ETB-100 (A100K10867)

Related Documentation

Doc. no.	Documentation
A100K11163	ETB Command Talk-Back & PA User Guide

Rules & Regulations

The ETB-5/ETB-10/ETB-10A/ETB-100/ETB-100A system and its components has been tested according to following regulations:

- **IEC 60533: Second edition, 1999**
“Electrical and electronic installation in ships - Electromagnetic compatibility”
- **IEC 60945: Fourth edition, 2002**
“Maritime navigation and radio communication equipment and systems - General requirements - Methods of testing and required test results”
- **IACS E10: Corr.1 July 2003**
“Unified environmental test specification - Testing procedure for electric control and monitoring, safety and protection, onboard computer based systems and peripherals, loading instruments, internal communication and other electrical equipment as considered appropriate”
- Complies with DNV ship requirements - “Main Class Cargo Ship Vessels for two way voice communication”
- ① **Does not comply with DNV ship requirements “C500 Nautical safety for two-way voice communication”**

1	System Overview	5
1.1	ETB-10 System Configuration	5
1.2	ETB-100 System Configuration	6
1.3	Features	7
1.4	System Components	7
1.5	Functions	8
1.5.1	General	8
1.5.2	Line Selection / Single Call	8
1.5.3	Group Call	9
1.5.4	All Call	9
1.5.5	Call from a Substation	9
1.5.6	Parallel Communication	9
1.5.7	Signal and Extra Signal Device for Substations	9
1.5.8	Extra Signal in the ETB Central Unit	10
1.5.9	Handsfree Operation	10
1.5.10	Privacy Function - STB-1	10
1.5.11	Panel Loudspeaker	10
1.5.12	External Loudspeaker (Option)	11
1.5.13	Line Button Dimmer	11
1.5.14	Volume Adjustment	11
1.5.15	Power Supply SPS-4 (Option)	11
1.5.16	Audio from External Systems (ETB-10A only)	11
1.5.17	Simple Public Address (ETB-100A only)	12
1.5.18	Emergency Public Address (ETB-100A only)	12
2	Installation & Configuration Procedures	13
2.1	General	13
2.2	Mounting	13
2.2.1	ETB Central Unit & Amplifier Cabinet RS-3C	13
2.2.1.1	Identification Label for ETB Central Unit	13
2.2.2	Substations & Other Equipment	13
2.2.2.1	Identification Label for Substation	13
2.3	Placement of Substations and Loudspeakers	13
2.4	Terminal Configurations	14
2.4.1	ETB-100 Terminal Configurations on PCB	14
2.4.2	ETB-5/ETB-10 Terminal Configurations on PCB	15
2.5	Cable Requirements	16
2.6	Power Supply Requirements	17
2.7	Volume Adjustment for Substation Lines	17
2.8	Extra Signal Device	17
2.9	Foot Switch for ETB Central Unit	17
2.10	Microphone Setup	17
2.11	Microphone Input Adjustment	17
2.12	Set Up Single/Group PA (ETB-100/ETB-100A only)	18
2.13	Substation STB-1	18
2.14	Substation STB-3	18
2.15	Substation STB-5	18
3	Operating Instructions	19
3.1	Operation from ETB Central Unit	19
3.1.1	Making a Call to a Substation	20
3.1.2	Making a Call to a Group of Substations	21
3.1.3	Making an All Call	22
3.1.4	Making a Handsfree Call Using Foot Switch	23
3.1.5	Sending Signal to Substations with Extra Signal Devices	23
3.1.6	Receiving a Call from a Substation	24
3.1.7	Receiving Calls from Two or More Substations	25

3.2	Parallel Communication	26
3.2.1	Operation of Parallel Communication	27
3.3	Audio from External Systems (ETB-10A only)	29
3.4	Simple Public Address (ETB-100A only).....	30
3.5	Emergency Public Address (ETB-100A only).....	31
3.5.1	Operation from PA Call Station 1 - ETB-100A.....	33
3.5.2	Operation from PA Call Station 2 - VMT-603	33
3.5.3	Operation from PA Call Station 3 - VMP-603	33
3.6	Operation from Substations	34
3.6.1	Operation from Substation STB-1.....	34
3.6.2	Operation from Substation STB-2.....	35
3.6.3	Operation from Substation STB-3.....	36
3.6.4	Operation from Substation STB-5.....	37
3.6.5	Operation from Substation STB-5GN	38
3.6.6	Operation from Substation HE-112M / HE-112M-T	39
3.6.7	Operation from Substation VH-10M / VH-10M-T	40
3.6.8	Operation from Substation VHM-10 / VHM-10-T	41
3.6.9	Operation from Substation NEBB-42EX	42
4	Commissioning.....	43
4.1	General	43
4.2	Mechanical Inspection	43
4.3	Cable Inspection	43
4.4	Check Configurations.....	43
4.5	Identification Labels	43
4.6	Starting Up the System	44
4.7	Functions Test Procedure	44
5	Troubleshooting.....	46
6	Dimension Drawings	48
6.1	ETB-5.....	48
6.2	ETB-10/ETB-10A	49
6.3	ETB-100/ETB-100A	50
7	Connection/Block/Single Line Diagrams.....	51
7.1	ETB-100 Single Line Diagram	51
7.2	ETB-5/ETB-10 Single Line Diagram	52
7.3	ETB-100 PCB Layout.....	53
7.4	ETB-5/ETB-10 PCB Layout	55
7.5	ETB-100 Block Diagram	57
7.6	ETB-5/ETB-10 Block Diagram	58
7.7	ETB-100 Cable Connection Diagrams.....	59
7.8	ETB-5/ETB-10 Cable Connection Diagrams.....	63

Zenitel Norway AS and its subsidiaries assume no responsibilities for any errors that may appear in this publication nor for damages arising from the information in it. No information in this publication should be regarded as a warranty made by Zenitel Norway AS.

The information in this publication may be revised or changed without notice. Product names mentioned in this publication may be trademarks and are used only for purposes of identification.

Zenitel Norway AS ©2011

1 System Overview

The ETB-5 & ETB-10/ETB-10A is a Command Talk-Back system with 5 or 10 lines while the ETB-100/ETB-100A is a Command Talk-Back & Public Address system with 10 lines. The ETB-100A can also be used as an emergency Public Address system. The system comprises a central unit and a comprehensive range of substations and other field equipment for use indoors, outdoors, and in noisy areas on marine vessels. The physical dimensions of the units are based on the Euro DIN standard and fit neatly into integrated bridge solutions.

1.1 ETB-10 System Configuration

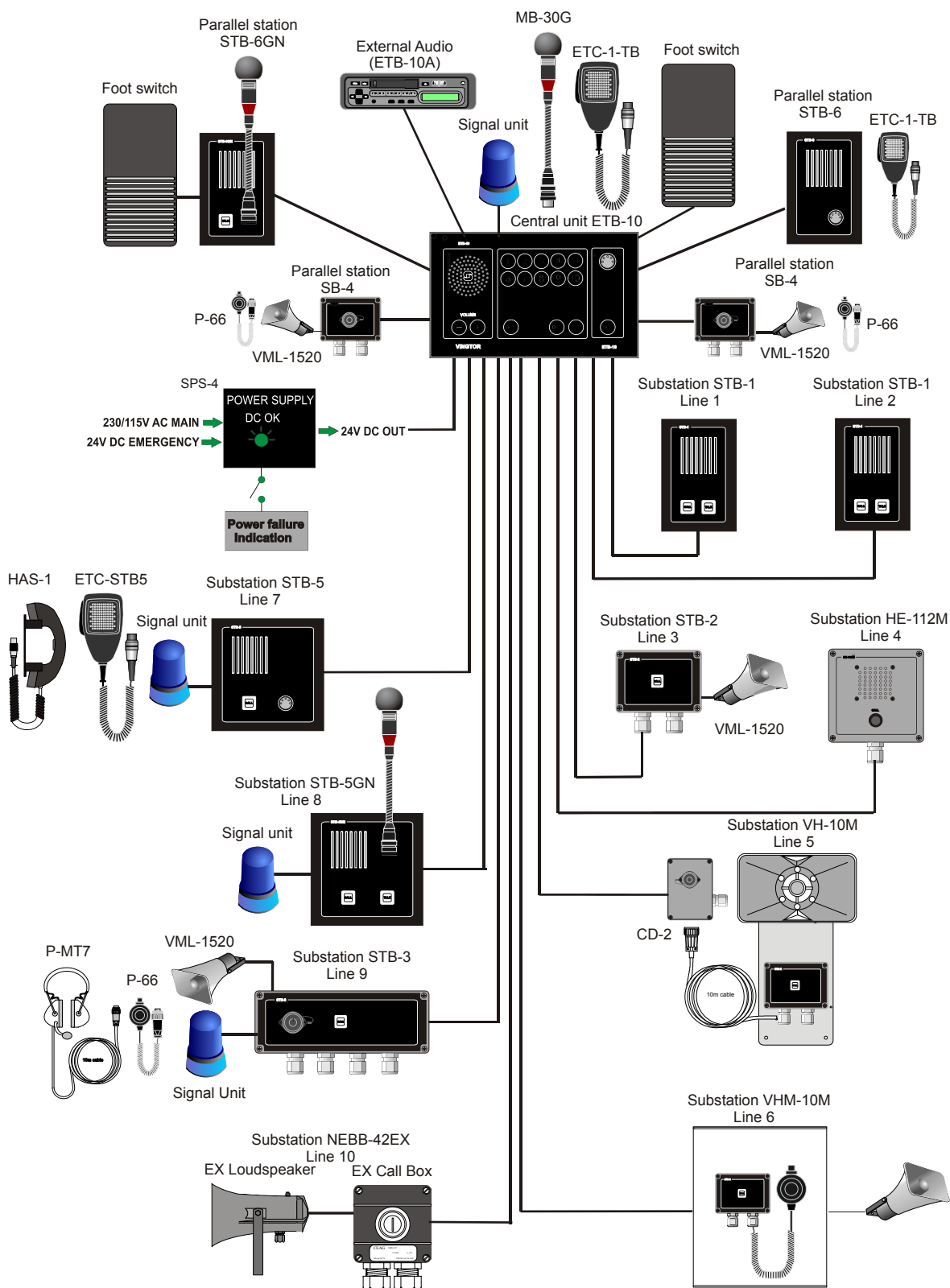

1.2 ETB-100 System Configuration

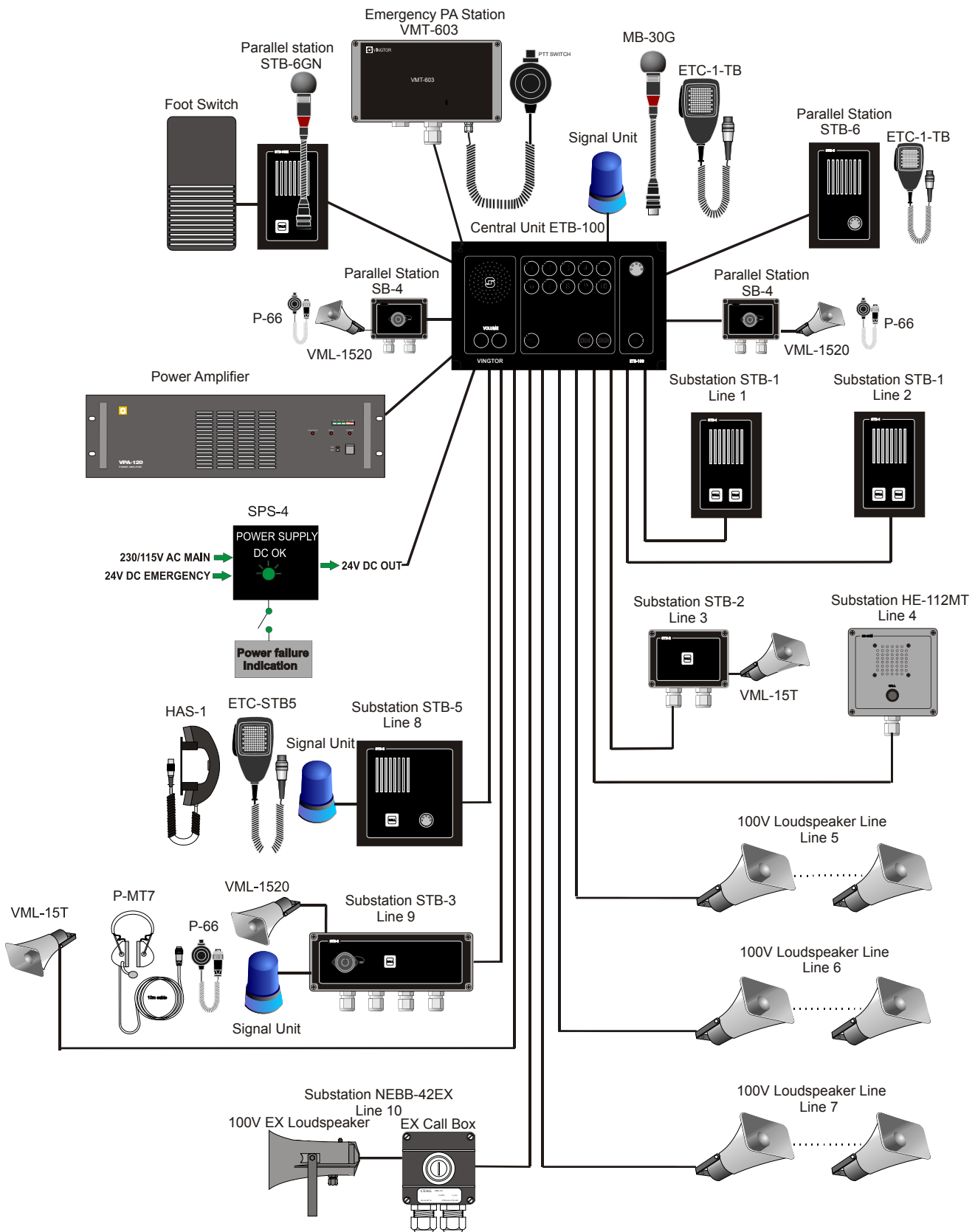

1.3 Features

- Command Talk-Back
- Dimmable call light
- 5 or 10 line selection
- Step volume control
- All Call
- Output for extra signal device - all lines
- Handheld or gooseneck microphone
- Output for parallel microphone and loudspeaker
- Handsfree operation with foot switch
- Console or wall mounting
- Power: 24-32 VDC
- Audio Message from external system (ETB-10A)
- Public Address operation (ETB-100A)
- 100V line power amplifier (ETB-100/ETB-100A)

1.4 System Components

Central Units, Microphones & Amplifiers

Name	Description	Item No.
ETB-5	Central Unit, panel mounted, IP44 - 5 lines	3005020022
ETB-10	Central Unit, panel mounted, IP44 - 10 lines	3005020018
ETB-10A	Central Unit with external PA, panel mounted, IP44 - 10 lines	3005020021
ETB-100	Central Unit, panel mounted, IP44 - 10 lines	3005020019
ETB-100A	Central Unit with external PA, panel mounted, IP44 - 10 lines	3005020020
MB-30G	Gooseneck Microphone with plug	3005020033
ETC-1-TB	Handheld microphone with curled cord and plug	3005020029
VPA-120	120W Power amplifier (for ETB-100/ETB-100A)	3005010235
VPA-240	240W Power amplifier (for ETB-100/ETB-100A)	3005010237
VPA-400	400W Power amplifier (for ETB-100/ETB-100A)	3005010239
RS-3C	Cabinet for power amplifier (for ETB-100/ETB-100A)	3006206019

Substations & Complementary Equipment

Name	Description	Item No.
STB-1	Substation, IP44, indoor, wall mounted with Call and Talk button	3005020057
STB-2	Call Box, IP66, watertight, used with VML-15T speaker	3005020058
STB-3	Combined Call/Plug Box, IP66, watertight, socket for mic & P-MT7 headset, relay unit for loudspeaker, extra signal device	3005020059
P-MT7	Headset w/ boom microphone, 10m cable and plug for STB-3	3005020050
VML-15T/F	Horn loudspeaker 15W 100V IP67 for STB-2	3006100090
VML-1520	Horn loudspeaker 15W 20 ohm IP67	3006100088
STB-5	Flush mounted substation, IP44, relay for microphone or handset	3005020060
STB-5GN	Flush mounted substation, IP44, relay & gooseneck microphone	3005020061
HAS-1	Handset for STB-5	3005020032
ETC-STB5	Handheld microphone with curled cord and plug for STB-5	3005020030
VH-10M	Portable deck loudspeaker with call box & 10m cable & plug	3006206030
VH-10M-T	Portable deck loudspeaker with call box & 10m cable & plug, 100V	3006206032

CD-2	Plug Box for VH-10M and VH-10M-T	1020600989
VHM-10	Deck unit with hand microphone mounted in cabinet	3006206034
VHM-10-T	Deck unit, with hand microphone mounted in cabinet, 100V	3006206035
HE-112M	Outdoor loudspeaker with call button, watertight, IP66	3006206006
HE-112M-T	Outdoor loudspeaker, 100V with call button, watertight, IP66	3006206007
NEBB-42EX	Call Box, EX-approved, IP67	3006206015

Bridge Wing Substations & Microphones

Name	Description	Item No.
STB-6	Flush mounted substation, IP44, for handheld mic ETC-1-TB	3005020062
STB-6GN	Flush mounted substation, IP44, with gooseneck microphone	3005020063
SB-4	Plugbox for mic, headset, loudspeaker, wall mounted, watertight	3005020053
P-66	Handheld microphone with curled cord and plug, watertight	3005020039
P-66/10	Handheld microphone with 10m cable and plug, watertight	3005020040

Additional Equipment

Name	Description	Item No.
WBOKS	Wall mounted backbox for ETB-5/ETB-10/ETB-100	3005020065
STBOKS5	Wall mounted backbox for STB-5/STB-5GN	3005010206
STBOKS	Wall mounted backbox for STB-6/STB-6GN	3005020064
SPS-4	Power supply 115/230V AC 24V DC w/ automatic switchover relay	3005020055
BLK5-24	Flash beacon 24V AC/DC 5 Joule, IP65	3006102023
EHS-24	Rotary light 24V DC, IP54	3006102038
A-100	Electronic alarm horn 24V DC, IP55, 100dB	3006102002
U2410	Foot switch for handsfree operation	3006206029

1.5 Functions

1.5.1 General

The system consists of one central unit, ETB-5, ETB-10, ETB-10A, ETB-100, or ETB-100A for use on the bridge console and a number of substations and loudspeakers for use indoors, outdoors, or in noisy areas.

The ETB-100 is for Command Talk-Back operation.

The ETB-100A is for Command Talk-Back and Public Address operation.

All the ETB central units have common functions except those that are specific to ETB-10A, ETB-100, or ETB-100A only (this will be indicated in the section heading).

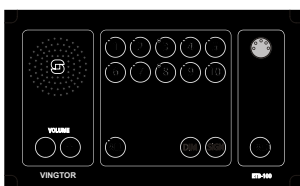

1.5.2 Line Selection / Single Call

Up to 5 substations for ETB-5 and 10 substations for ETB-10/ETB-10A/ETB-100/ETB-100A can be selected by pressing the respective line button on the central unit.

Activation is indicated by a steady green LED.



1.5.3 Group Call

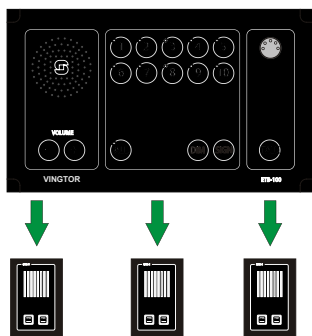

A group of substations can be selected by pressing the respective line buttons.

Activation is indicated by a steady green LED.

1.5.4 All Call

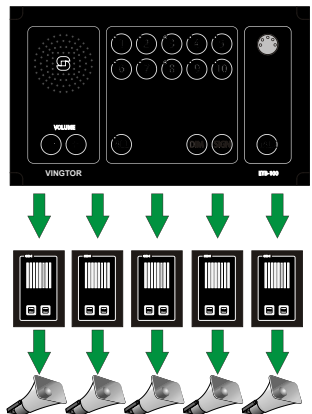

All call message can be distributed by pressing the **ALL** button.

Activation is indicated by a steady green LED in the **ALL** button.

1.5.5 Call from a Substation

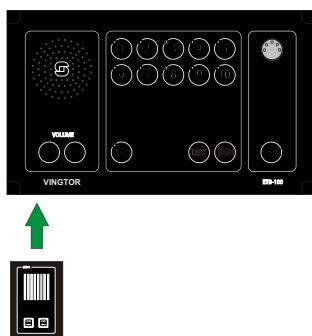

Calls can be made from any substation to the ETB central unit.

Activation is indicated by a flashing green LED in the respective line button and a call tone from the panel speaker.

1.5.6 Parallel Communication

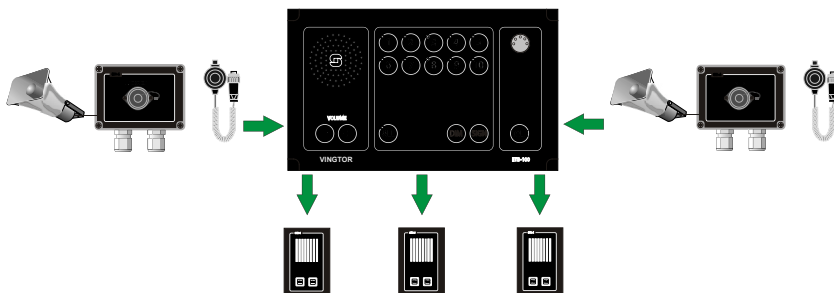

Operation of the ETB central unit is made from parallel microphones/loudspeakers located on bridge wings or other locations where required.

① Note that line selection has to be set up from the central unit.

1.5.7 Signal and Extra Signal Device for Substations

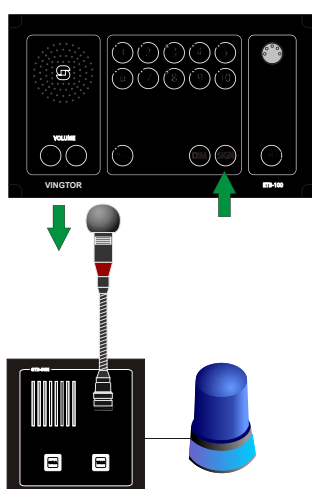

A call signal can be given to selected station. The function will also activate an 24VDC max 50mA to substation with relay or direct connected external signal device

1.5.8 Extra Signal in the ETB Central Unit

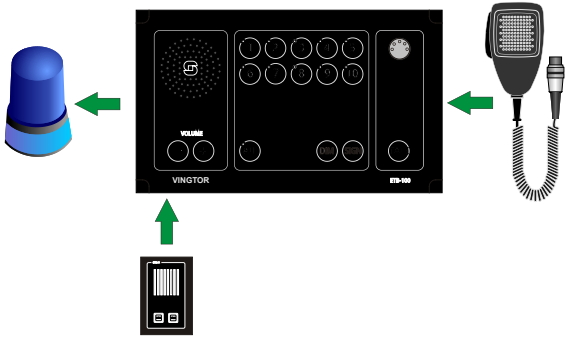

An extra signal device can be activated when receiving calls from a substation through a potential-free contact in the central unit.

1.5.9 Handsfree Operation

Handsfree operation of central unit or parallel station.

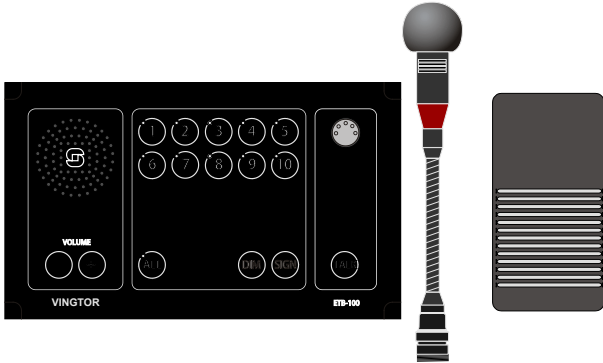

Option 1

Central unit with gooseneck microphone MB-30G and foot switch U2410.

Parallel Station STB-6GN

Option 2

Parallel station type STB-6GN with gooseneck microphone MB-30G and foot switch U2410.

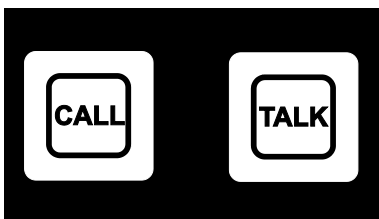
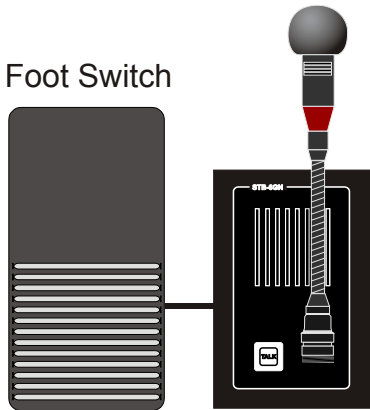

1.5.10 Privacy Function - STB-1

Substation STB-1 is designed for indoor use such as cabins, mess rooms, etc. It is also equipped with a privacy function.

When the privacy function is enabled, it is not possible to hear communication from the STB-1 substation on the ETB central unit.

After a call is set up from the central unit, the operator of the STB-1 substation has to press the TALK button to communicate with the central unit.

STB-1 can also be set to normal talk-back function.

1.5.11 Panel Loudspeaker

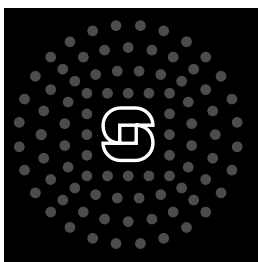

The loudspeaker is located at the front panel of the ETB-100 and ETB-100A central unit for distribution of audio messages and alarm signals.

1.5.12 External Loudspeaker (Option)

The optional external loudspeaker with 40W impedance is for improved and higher audio volume level.

The loudspeaker is connected in parallel with the monitor speaker and located close to the ETB central unit.



1.5.13 Line Button Dimmer

The intensity of the line button light can be adjusted by pressing the button labeled **DIM**.

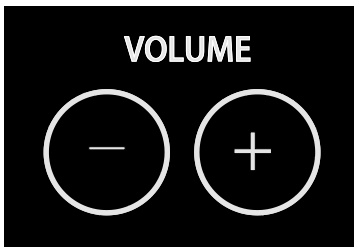

1.5.14 Volume Adjustment

By pressing the + or - buttons repeatedly, you can progressively increase or decrease the speaker volume in the central unit

This will also affect the volume for an external speaker connected to the panel.

- Press the + button to increase the volume
- Press the - button to decrease the volume

1.5.15 Power Supply SPS-4 (Option)

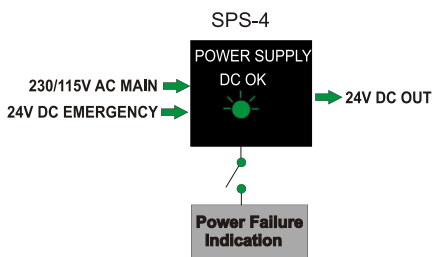

The power supply SPS-4 is designed with power failure contact and automatic switch-over relay.

This means that there is an indication and automatic switch-over to 24V DC emergency power supply when the mains supply or power module fails.

1.5.16 Audio from External Systems (ETB-10A only)

Entertainment, message or alarm messages can be distributed through the ETB-10A system.

An potential-free contact and 0 dB signal from the external system activate the ETB-10A to send the message to all substations.

The **TALK** button on ETB-10A or the PTT switch on the handheld microphone will override the external audio.

Normal talk-back functions can not be used in this mode.

The external system may be:

- VHF radio
- Entertainment system
- Alarm system
- Public Address

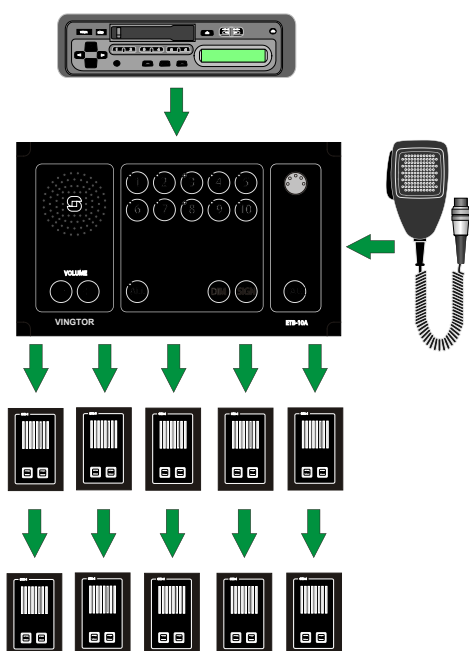

1.5.17 Simple Public Address (ETB-100A only)

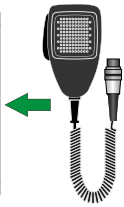
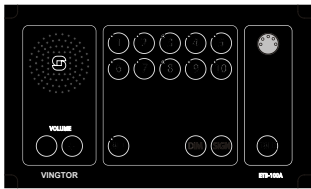

A single line or group of loudspeaker lines can be set to Simple PA mode. Fixed settings for selected lines are made through DIP switches. All lines can be set to this mode. The remaining lines provide normal Talk-Back function.

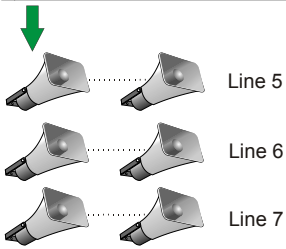

1.5.18 Emergency Public Address (ETB-100A only)

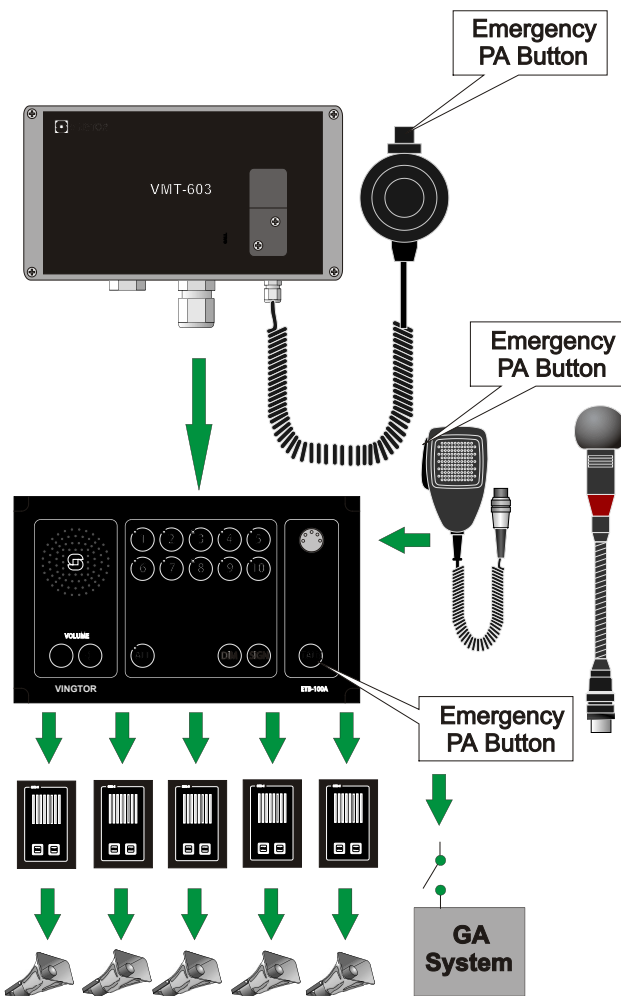

In order to comply with PA requirements, the ETB-100A system is designed with a minimum of two PA call stations for Emergency PA for all lines.

Call station 1

Central unit ETB-100A with hand microphone or gooseneck microphone.

Call station 2

VMT-603 with hand microphone or gooseneck microphone

- Muting of the General Alarm System
- Overriding of all other input, including Talk-Back and simple Public Address Operation.
- ETB-100A has 1st priority and will override emergency call station 2.

2 Installation & Configuration Procedures

2.1 General

For proper installation and operation of the ETB system, we recommend reading this section thoroughly together with technical and connection drawings in the section 7.

All configuration settings such as volume, foot switch, microphone, etc. are located on the ETB main board *ETB510*.

Refer to technical drawings in section 7 *Connection/Block/Single Line Diagrams* for more detailed information.

- ① *In order to comply with DNV ship requirements, this section has to be followed strictly.*

2.2 Mounting

2.2.1 ETB Central Unit & Amplifier Cabinet RS-3C

The ETB central unit is the basis of the system. It should be flush or bulkhead mounted in a normal and ventilated indoor environment with a temperature of maximum 55 °C.

Make sure that there is sufficient space for cables and maintenance.

2.2.1.1 Identification Label for ETB Central Unit

A label with the line numbers for all substations should be placed close to the ETB central unit.

2.2.2 Substations & Other Equipment

See the respective drawings for dimensions, cut-out and mounting of substations such as STB-1, STB-2, etc.

Make sure that there is sufficient space for cables and maintenance.

2.2.2.1 Identification Label for Substation

A label with the substation number has to be placed on or close to each substation.

Line No.	Substation
1	STB-1
2	STB-1
3	STB-2
4	HE-112M
5	VH-10M
6	VHM-10
7	STB-5
8	STB-5GN
9	STB-3
10	NEBB-42EX

2.3 Placement of Substations and Loudspeakers

To avoid acoustic feedback, it is recommended to place the 100V loudspeakers such that they face away from the ETB central unit.

2.4 Terminal Configurations

Pluggable screw terminals for cables of max. 2.5 mm² are utilized.

Refer to technical drawings in section 7 *Connection/Block/Single Line Diagrams* for more detailed information.

2.4.1 ETB-100 Terminal Configurations on PCB

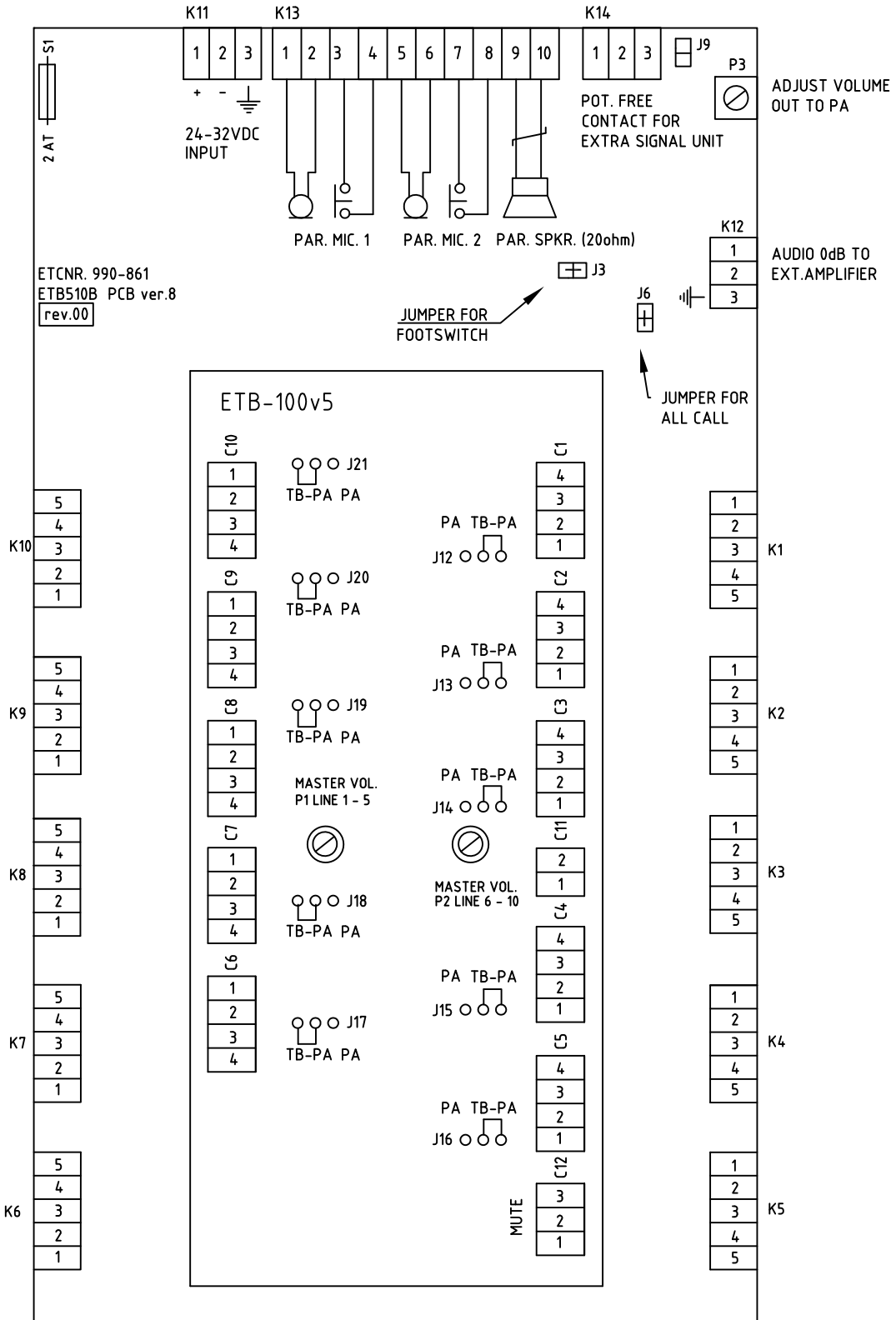

2.4.2 ETB-5/ETB-10 Terminal Configurations on PCB

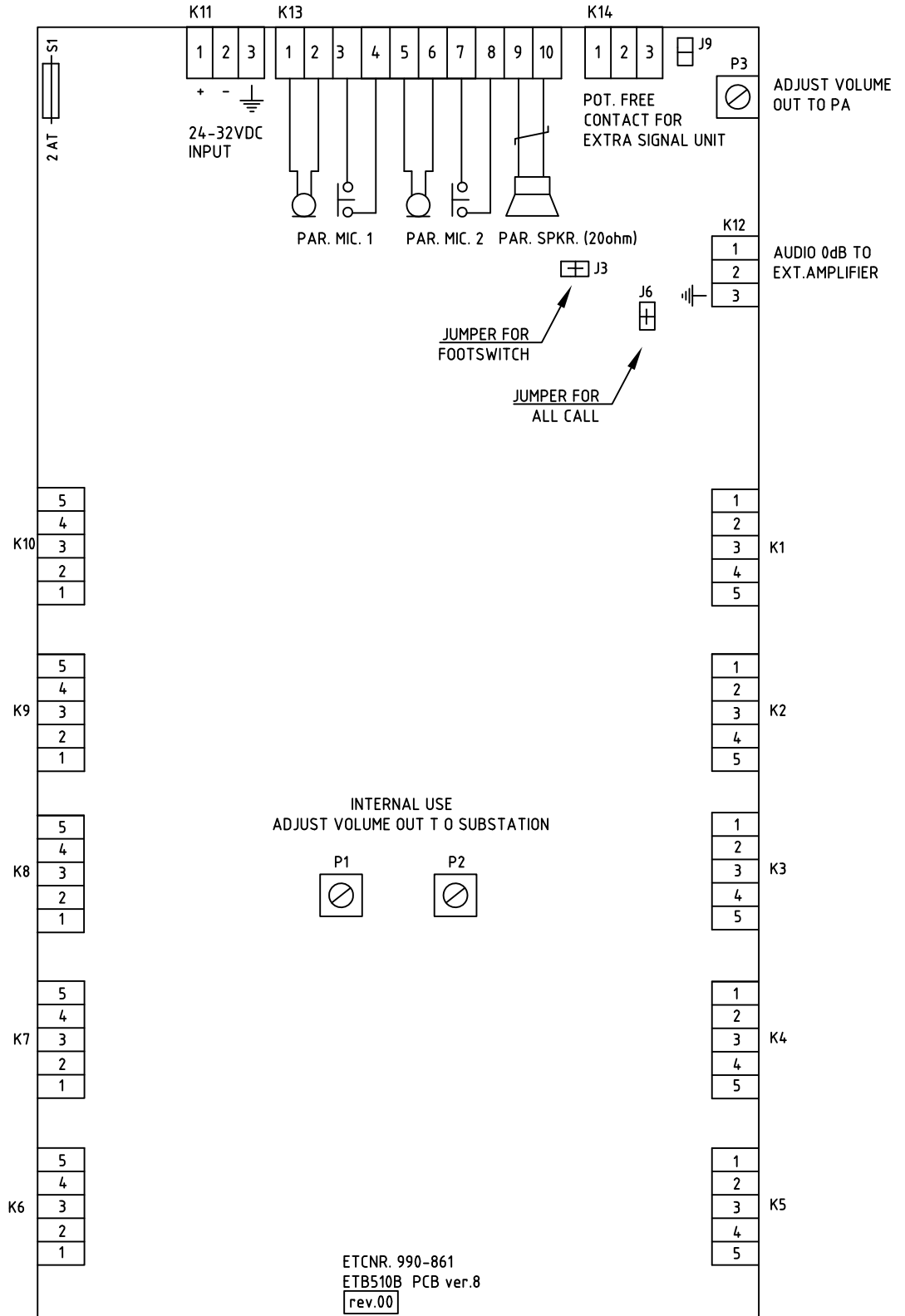

Terminal block C1 - C10 (ETB-100/ETB-100A only)

- No. 1-2 for substation line, low impedance
- No. 3-4 for substation line, 100V to extra signal device

Terminal block K1 - K5 (for ETB-5)

Terminal block K1 - K10 (for ETB-10/ETB-100)

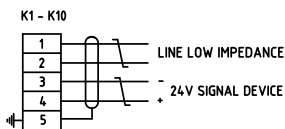

- No. 1-2: substation line for ETB-10 (not in use for ETB-100)
- No. 3-4: 24V DC to extra signal device
- No. 5: common ground point for each substation screen

Terminal block K11

- For power supply

Terminal block K12

- For power amplifier (NOT for ETB-5/ETB-10)

Terminal block K13

- Parallel microphone and parallel loudspeaker

Terminal block K14

- Potential-free contact for activating/muting external system or extra signal device

Terminal block C11 (ETB-100/ETB-100A only)

- 100V line in from power amplifier

Terminal block C12 (ETB-100/ETB-100A only)

- Muting of external alarm system

Terminal block K1 (ETB-100A only)

- Located on PCB labeled **ETB-ALL-SUB**
- For connection to Emergency PA station:
 - No. 1-2 audio
 - No. 3-4 switch
 - No. 5 screen

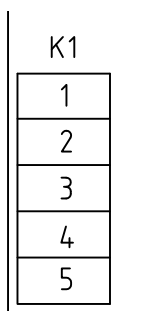

2.5 Cable Requirements

All signal cables have to be approved ship cable of type twisted-pair with outer braided copper shield.

① See cable connection diagrams in Section 7 for further details.

The screens must be interconnected in junction boxes and grounded in a common point in the central unit only.

Terminal block K1 – K10 no. 5 is the ground point for each substation screen.

The power cable must be approved ship cable of minimum 3 x 0.75 mm².

Maximum cable length = 500 meters

① The central unit has to be connected to the vessel's central ground. Proper grounding is essential for reliable operation.

① Ensure that signal cables are separated from power cables.

2.6 Power Supply Requirements

- 24 VDC -10% + 33% (21.6 – 32 VDC)
- Current consumption max. 2A

System power supply should be wired and fused independently from other systems:

- 24V DC from ship's 24V DC system.
- 24V DC from power supply SPS-4 230V AC / 24V DC with automatic switch to 24V DC emergency power supply.

2.7 Volume Adjustment for Substation Lines

System volume for substations can be adjusted by separate trimmer for each group of 5 lines: master volume lines 1-5 and lines 6-10.

Volume is factory set and does not normally require any adjustment.

If the installation on some locations requires another sound pressure level, this can be changed to the desired audibility and volume.

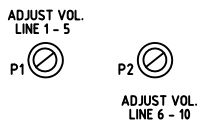

2.8 Extra Signal Device

The maximum load for each substation line is 50 mA to substation with relay unit or signal device (connected on terminal block K1 – K10 no. 3-4). The maximum load from substations STB-3 and STB-5 is 2A.

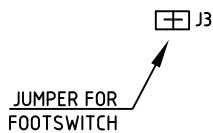
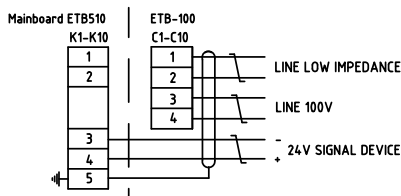

2.9 Foot Switch for ETB Central Unit

The foot switch is used together with the ETB central unit and gooseneck microphone.

When the foot switch is used, the jumper labeled **JUMPER FOR FOOT SWITCH** on the main board has to be removed.

2.10 Microphone Setup

The jumper J8 has to be set to Microphone.

This is the default setting and does not normally need to be changed.

USE INTERNAL SPEAKER AS MICROPHONE



2.11 Microphone Input Adjustment

Input for microphones can be adjusted via the potentiometer labeled P1.

The input level is factory set and does not normally require any adjustment.

MICROPHONE VOLUME (INTERNAL USE)



2.12 Set Up Single/Group PA (ETB-100/ETB-100A only)

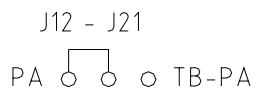

Each line can be set to Single or Group PA without talk-back.

The jumpers labeled **J12** to **J21** for each line (on ETB-100 main board) have to be set in position **PA**.

2.13 Substation STB-1

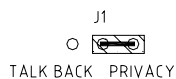

The default setting for substation STB-1 is **PRIVACY**.

Set jumper **J1** on the PCB in substation STB-1 to **Talk-Back** if required.

2.14 Substation STB-3

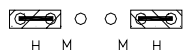

The default setting for substation STB-3 is **Headset**.

Set the two jumpers on the PCB in substation STB-3 to **Microphone** if required.

2.15 Substation STB-5

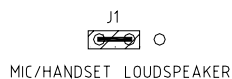

The default setting for substation STB-5 is **HANDSET**.

Set jumper **J1** on the PCB in substation STB-3 to **LOUDSPEAKER** if required.

3 Operating Instructions

3.1 Operation from ETB Central Unit

The ETB Talk-Back system comprises the ETB central unit and accessory equipment such as microphones and foot switch.

Central Unit ETB-5/ETB-10/ETB-10A/ETB-100/ETB-100A

Ingress Protection Rating = IP44

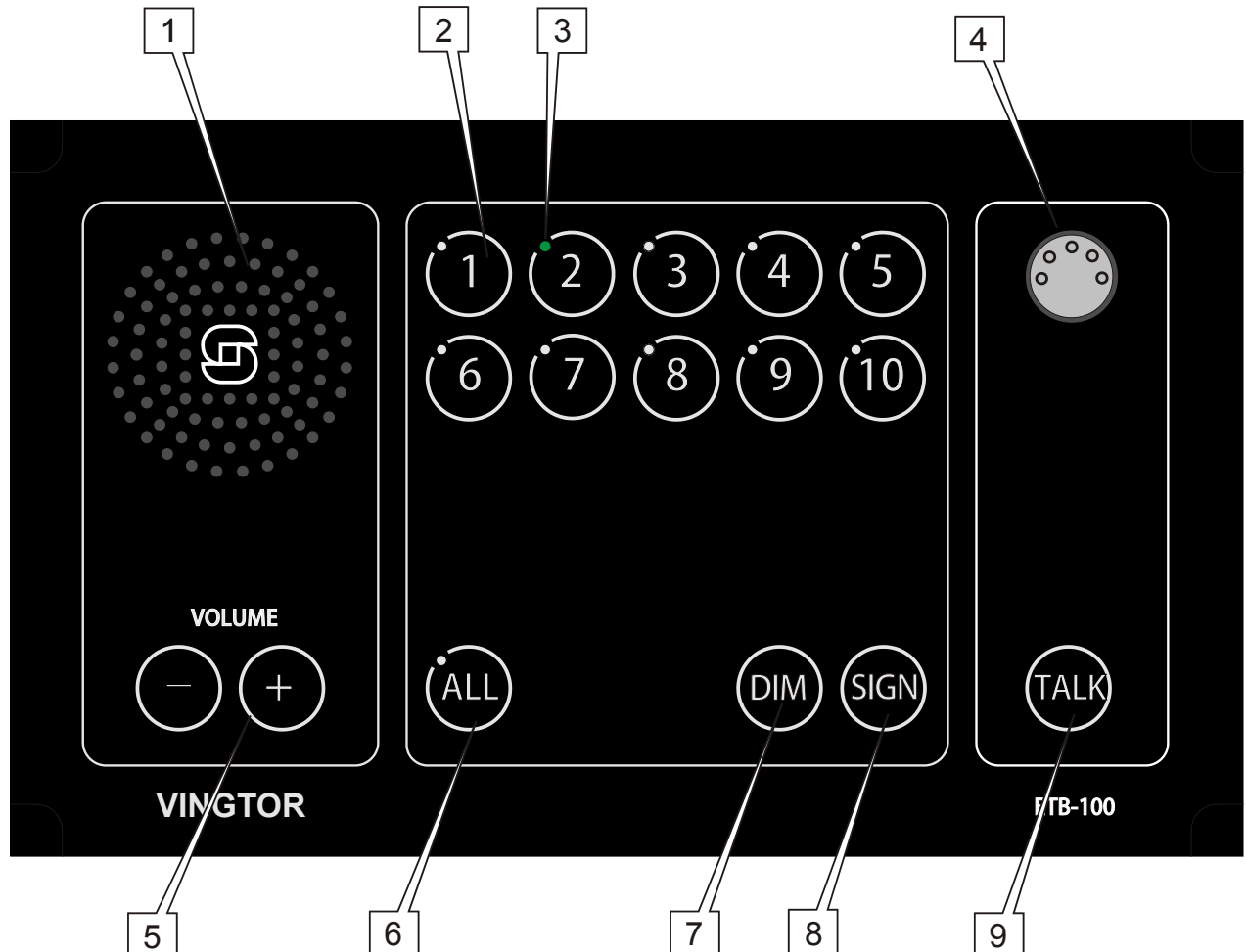

1. **Loudspeaker:** For communication and alarm signals
2. **Line Buttons:** Lines 1-5 for ETB-5, Lines 1-10 for ETB-10/ETB-10A and ETB-100/ETB-100A
3. **Green LED:** Indication light for each line button
4. **Microphone Connector:** For gooseneck or handheld microphone
5. **VOLUME - +:** Volume control buttons for panel loudspeaker
6. **ALL:** Button with indication LED for making All Call
7. **DIM:** Button for adjusting light intensity of indication LEDs
8. **SIGN:** Button for signal and activating extra signal device on substations
9. **TALK:** PTT switch for gooseneck microphone MB-30G

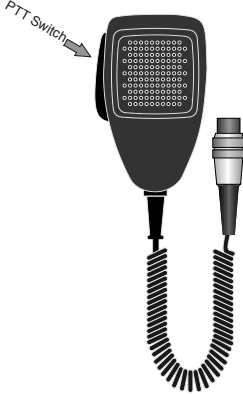
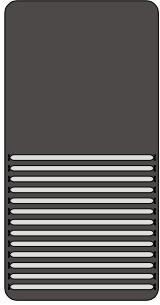
Gooseneck Microphone MB-30G	Handheld Microphone ETC-1-TB with PTT switch	Foot Switch U2410 for handsfree operation of microphone MB-30G
		

3.1.1 Making a Call to a Substation

You can select the substation by pressing the desired line push button.

A steady green LED will indicate the activated line.

If desired, the signal button **SIGN** may be pressed to send a tone signal to the selected station. Pressing the **TALK** button enables talking from the ETB central unit. The central unit will be in listening mode as soon as a station is selected. To terminate the communication, press the selected line button again. The LED will stop being lit to indicate that the selected line is terminated.

- Press the line button
 - the call is set up, indicated by a steady green LED



- Press the **SIGN** button



A tone signal will be activated at the selected station as long as the SIGN button is kept pressed.

This will also activate an extra signal to substations equipped with these devices.



ETB central unit with gooseneck microphone MB-30G

- Press the **TALK** button
- Speak clearly into the microphone

When the TALK button is released, the ETB will be in listening mode and you will hear the communication from the selected station in the panel loudspeaker.

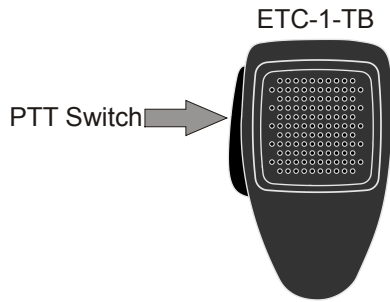

ETB central unit with handheld microphone ETC-1-TB

- Press the PTT switch on the microphone
- Speak clearly into the microphone

When the PTT switch is released, the ETB will be in listening mode and you will hear the communication from the selected station in the panel loudspeaker.



- Press the line button once more to terminate the call.

When the call terminates, the LED will stop lighting.

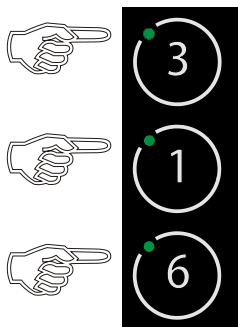

3.1.2 Making a Call to a Group of Substations

You can select a group of substations by pressing the respective line buttons.

The ETB central unit always has the 1st priority and can select between the substations.

Only the ETB central unit can switch off and terminate the call.

- Press the required line buttons
 - The call is set up, indicated by the LEDs lighted a steady green in the selected buttons.
- Press the **SIGN** button
 - A tone signal will be broadcasted to the selected station as long as the SIGN button is kept pressed. This will also activate a signal to substations equipped with extra signal devices.



ETB central unit with gooseneck microphone MB-30G

- Press the **TALK** button
- Speak clearly into the microphone

When the TALK button is released, the ETB will be in listening mode, and you will hear the communication from the selected station.

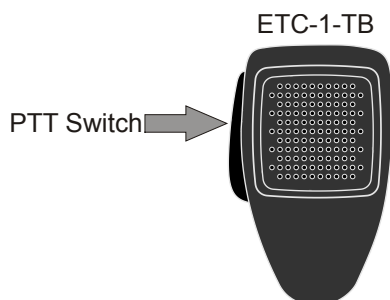
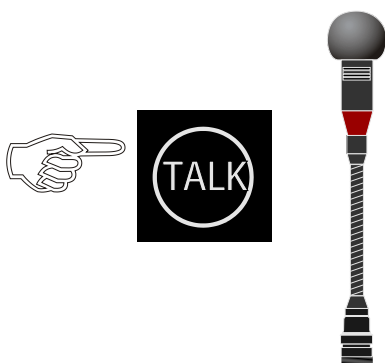

ETB central unit with handheld microphone ETC-1-TB

- Press the PTT switch on the microphone

Speak clearly into the microphone. When the PTT switch button is released the ETB will be in listening mode, and you will hear the communication from the selected station.

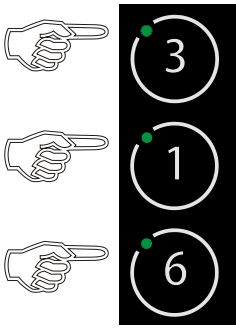

- Press the active line buttons once more to terminate the calls.

When the calls terminate, the LEDs will stop lighting.

3.1.3 Making an All Call

The message and signal from ETB will be given to all substations, as a one-way message.

It will be indicated by a steady green LED in the ALL button. Talk-back from substations is disabled in this mode.



- Press the **ALL** button
 - the call is set up, indicated by steady green LED in the ALL button



- Press the **SIGN** button
 - A tone signal will be broadcasted to the selected station as long as the SIGN button is kept pressed. This will also activate a signal to substations equipped with extra signal devices.

ETB central unit with gooseneck microphone MB-30G



- Press the **TALK** button

Speak clearly into the microphone. When the TALK button is released the ETB will be in listening mode, and you will hear the communication from the selected station.

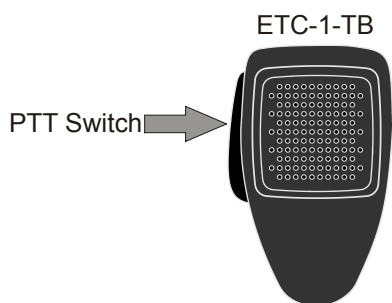

ETB central unit with handheld microphone ETC-1-TB

- Press the PTT switch on the microphone

Speak clearly into the microphone. When the PTT switch button is released the ETB will be in listening mode, and you will hear the communication from the selected station.



- Press the ALL button once more to terminate the call

When the call terminates, the LED will stop lighting.

3.1.4 Making a Handsfree Call Using Foot Switch

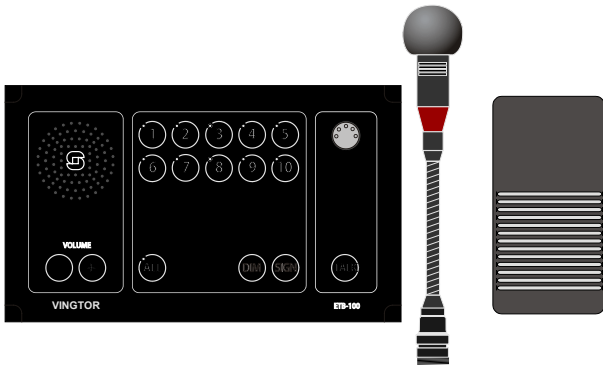

The equipment required in making a handsfree call from the ETB central unit are a gooseneck microphone (MB-30G) and a foot switch (U2410).

- Press the foot switch
- Speak clearly into the microphone

When the foot switch is released, the ETB will be in listening mode, and you will hear the communication from the selected station.

① *Jumper labeled **Jumper for foot switch** must be removed for this function.*

3.1.5 Sending Signal to Substations with Extra Signal Devices

Substations STB-3, STB-5 and STB-5GN are equipped with a relay for activating extra signal devices.

An extra signal device can be a flashing beacon, rotary light, and alarm horn and bells.

On the ETB central unit:

- Press the **SIGN** button

A tone signal will be activated on the selected station as long as the SIGN button is kept pressed.

Indication 1

There will be a tone signal from the panel loudspeaker of substation STB-5 or STB-5GN, or from the horn loudspeaker of substation STB-3.

Indication 2

A signal will also be activated on the extra signal devices such as a flashing beacon, rotary light, alarm horn and bells.

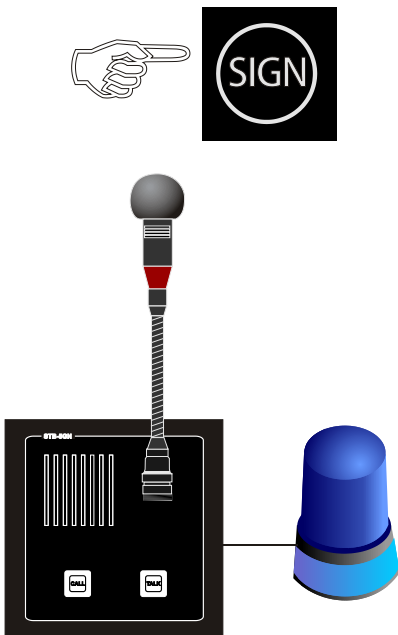



3.1.6 Receiving a Call from a Substation

An incoming call is indicated by a flashing green LED in the respective line button and a beeping tone in the panel loudspeaker.

It will also activate an extra signal unit if installed. Only the ETB central unit can terminate the call.

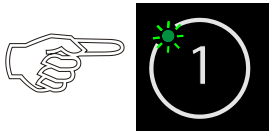

- Press the line button with the flashing green LED
- the call is set up, indicated by a steady green LED

ETB central unit with gooseneck microphone MB-30G

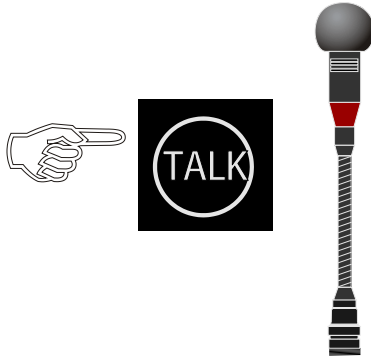

- Press the **TALK** button
- Speak clearly into the microphone

When the TALK button is released the ETB will be in listening mode, and you will hear the communication from the selected station.

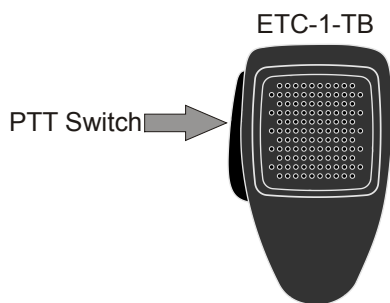

ETB central unit with handheld microphone ETC-1-TB

- Press the PTT switch on the microphone
- Speak clearly into the microphone

When the PTT switch button is released the ETB will be in listening mode, and you will hear the communication from the selected station.

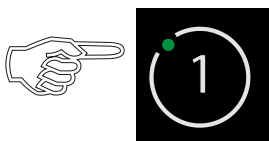

- Press the line button once more to terminate the call.

When the call terminates, the LED will stop lighting.

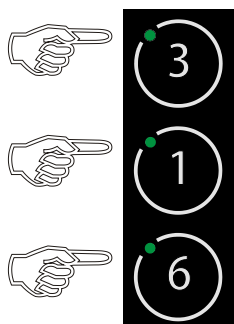
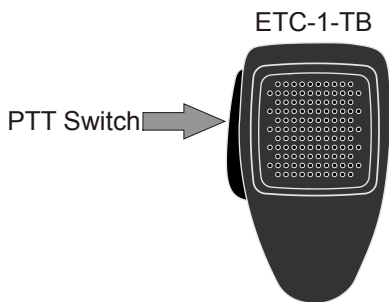
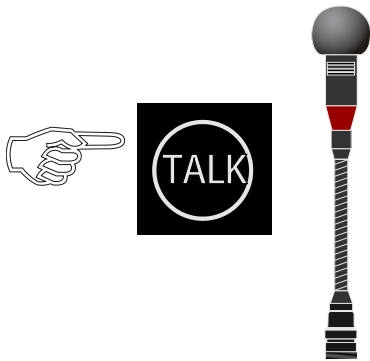
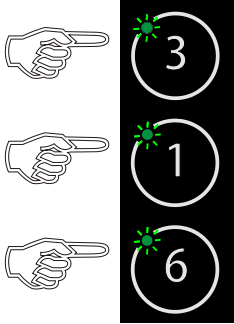

3.1.7 Receiving Calls from Two or More Substations

Calls can be received from two or more substations at the same time. The ETB central unit has the 1st priority and can select between calls from the substations. Only the ETB central unit can terminate the calls.

Incoming calls are indicated by flashing green LEDs in the respective line buttons and a beeping tone in the panel loudspeaker.

The calls will also activate an extra signal unit if installed (only for the first call).

- Press the line buttons with the flashing green LEDs
- the calls are set up, indicated by a steady green LED

The ETB central unit can select between substation lines and terminate calls by pressing the respective line buttons once more.

ETB central unit with gooseneck microphone MB-30G

- Press the **TALK** button
- Speak clearly into the microphone

When the TALK button is released the ETB will be in listening mode, and you will hear the communication from the selected station.

ETB central unit with handheld microphone ETC-1-TB

- Press the PTT switch on the microphone
- Speak clearly into the microphone

When the PTT switch button is released the ETB will be in listening mode, and you will hear the communication from the selected station.

- Press the active line buttons once more to terminate the calls.

When the calls terminate, the LEDs will stop lighting.

3.2 Parallel Communication

Parallel communication functions with the operation of the ETB central unit from parallel microphones/loudspeakers located on bridge wings or other locations near the central unit where parallel microphones/loudspeakers are needed.

Two parallel stations can be connected. Communication is set up by the ETB central unit. The bridge wing unit will be in operation mode as soon as a station is selected on the ETB central unit.

Parallel Station STB-6

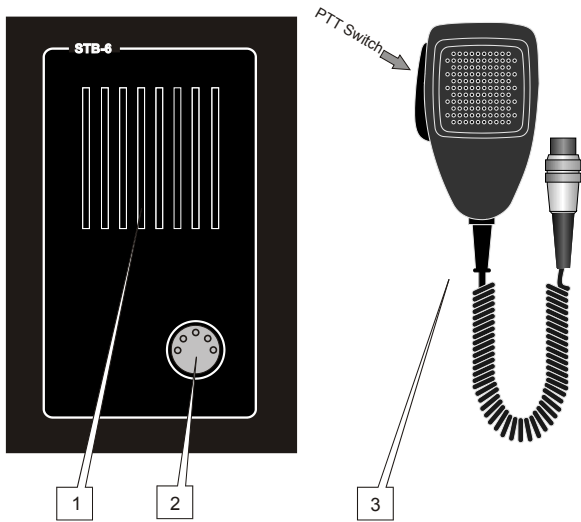

1. **Loudspeaker:** Parallel to central unit
2. **Connector:** For microphone
3. **Microphone:** ETC-1-TB with PTT switch

Parallel Station STB-6GN

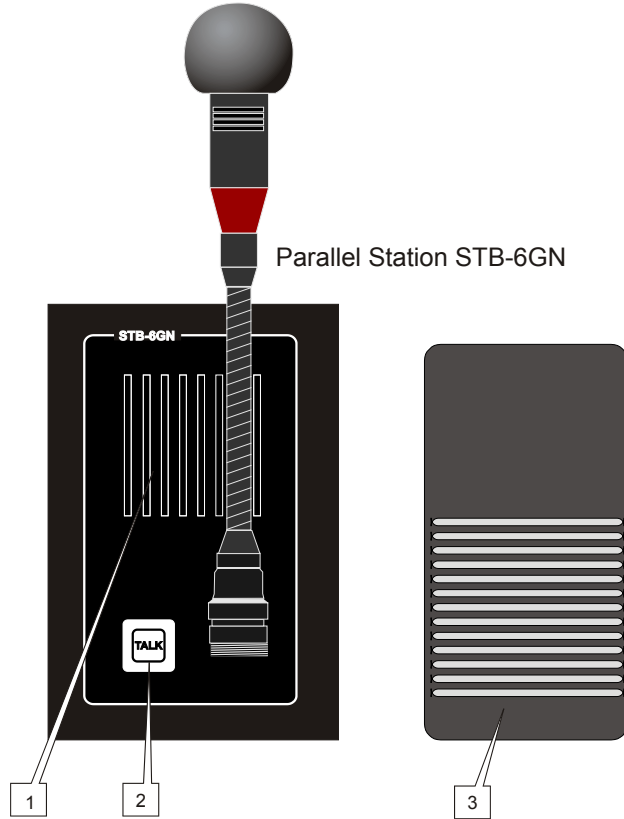

1. **Loudspeaker:** Parallel to central unit
2. **TALK:** PTT switch for microphone (Parallel to central unit)
3. **Foot Switch:** Parallel to PTT switch

Parallel Station SB-4

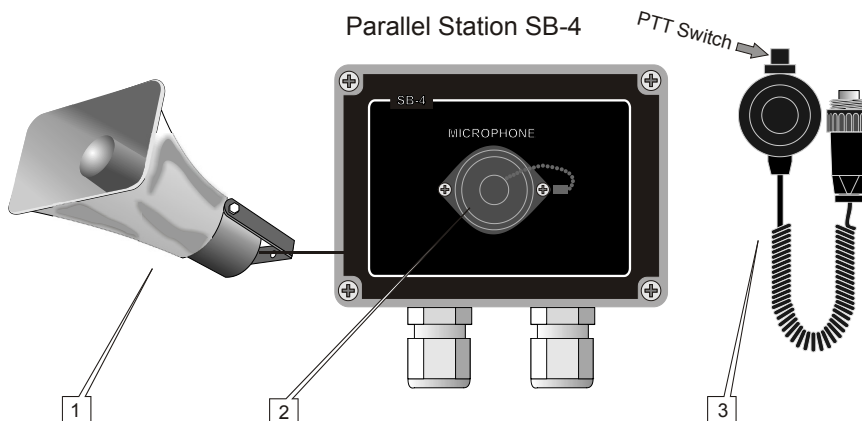

1. **Loudspeaker:** Parallel to central unit
2. **Connector:** For microphone
3. **Microphone:** P-66 with PTT switch (parallel to microphone on central unit)

3.2.1 Operation of Parallel Communication

① Note that line selection and signal have to be set up from the ETB central unit.

ETB Central Unit



- Press the line button on the ETB central unit
- the call is set up, indicated by a steady green LED



- Press the **SIGN** button on the ETB central unit

A tone signal will be sent to the selected station as long as the SIGN button is being pressed.

This will also activate a signal to substations equipped with extra signal devices.

Parallel Station STB-6 with Handheld Microphone

Ingress Protection Rating = IP44

Parallel Station STB-6

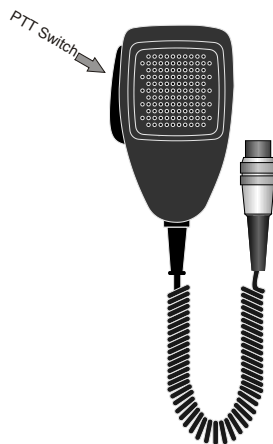
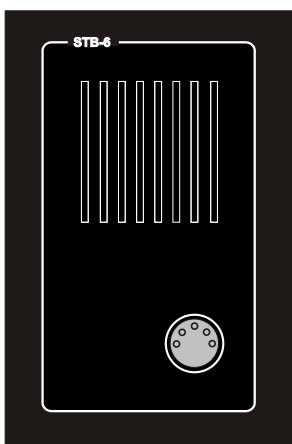

- Press the PTT switch on the handheld microphone ETC-1-TB
- Speak clearly into the microphone

When the PTT switch button is released, the parallel station will be in listening mode and you will hear the communication from the selected station in the loudspeaker.

Parallel Station STB-6GN with Gooseneck Microphone

Ingress Protection Rating = IP44

Parallel Station STB-6GN

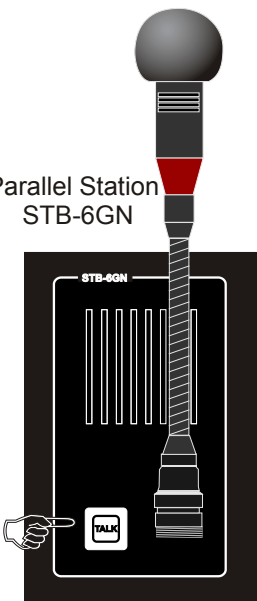

- Press the **TALK** button on the STB-6GN station
- Speak clearly into the microphone

When the **TALK** button is released, the parallel station will be in listening mode, and you will hear the communication from the selected station in the panel loudspeaker.

Handsfree Operation

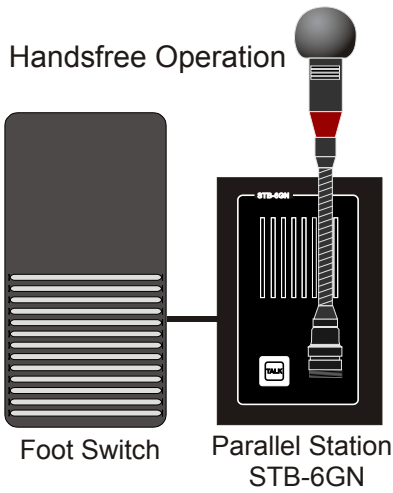

Parallel Station STB-6GN Handsfree Operation Using Foot Switch

- Press the foot switch
- Speak clearly into the microphone

When the foot switch is released, the parallel station will be in listening mode, and you will hear the communication from the selected station in the panel loudspeaker.

Parallel Station SB-4 with Microphone & Horn Loudspeaker

Ingress Protection Rating = IP66

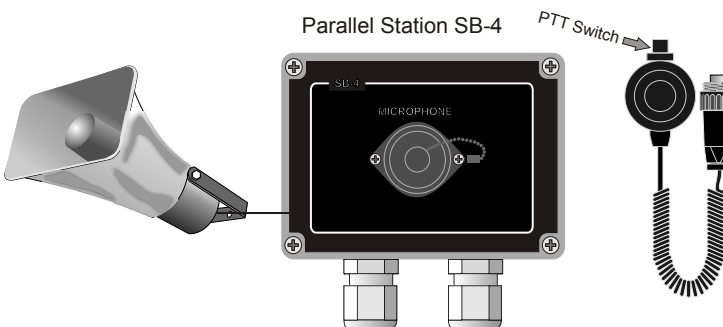

The parallel station comprises the SB-4 Plug box, P-66 microphone, and VML-1520 horn loudspeaker.

- Press the PTT switch on the handheld microphone P-66
- Speak clearly into the microphone.

When the PTT switch is released, the parallel station will be in listening mode and you will hear the communication from the selected station.



- Press the line button on the ETB central unit once more to terminate the call

When the call terminates, the line button LED will stop lighting.

3.3 Audio from External Systems (ETB-10A only)

Entertainment, message or alarm messages can be distributed by using the ETB-10A central unit and all substations.

An potential-free contact and 0 dB signal from the external system activate the ETB-10A to send the message to all substations.

The **TALK** button on ETB-10A or the PTT switch on the handheld microphone will override the external audio.

Normal talk-back functions can not be used during this mode.

An external system may be VHF radio, entertainment system, alarm system, and Public Address.

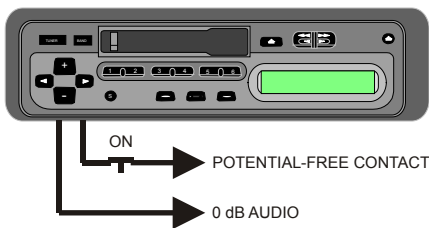

To start the function:

- Switch on the external equipment
 - the audio will be distributed to all substations and in the ETB-10A central unit.

To override the function using ETB-10A with gooseneck microphone MB-30G:

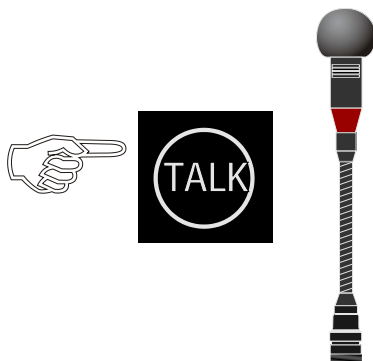

- Press the TALK button on the ETB-10A central unit
- Speak clearly into the gooseneck microphone
 - When the TALK button is released, the ETB-10A will be in external All Call mode again

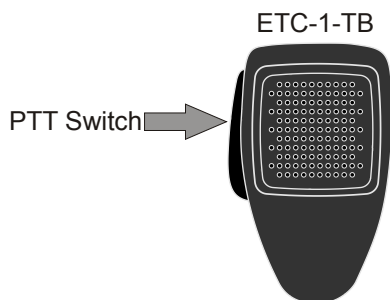

To override the function using ETB-10A with handheld microphone ETC-1-TB:

- Press the PTT switch on the handheld microphone
- Speak clearly into the handheld microphone
 - When the PTT switch is released, the ETB-10A will revert back to All Call mode.

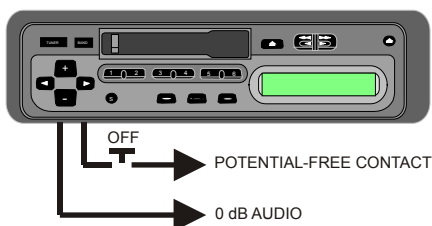

To terminate the function:

- Switch off the external equipment
 - the ETB-10A will revert back to normal Talk-Back mode

3.4 Simple Public Address (ETB-100A only)

A single line or group of loudspeaker lines must be set to Public Address as a fixed configuration.

The Public Address function is set by DIP switches (see section 3.11).

① *The Talk-Back function can not be used for the lines that are configured for Public Address.*

Single Call



- Press the line button
 - The call is set up, indicated by a steady green LED.

Group Call

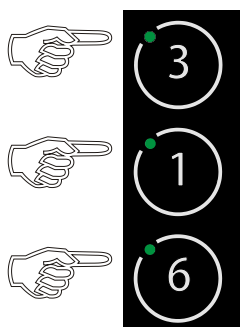

- Press the required line buttons
 - The call is set up, indicated by the LEDs lighted a steady green in the selected buttons.

ETB central unit with gooseneck microphone MB-30G



- Press the **TALK** button
- Speak clearly into the microphone

ETB central unit with handheld microphone ETC-1-TB

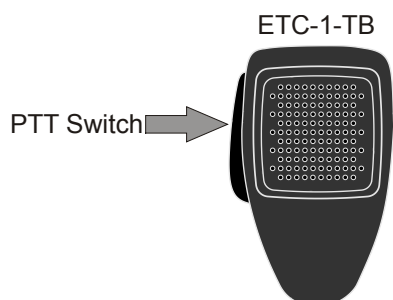

- Press the PTT switch on the microphone
- Speak clearly into the microphone

Terminating the Calls

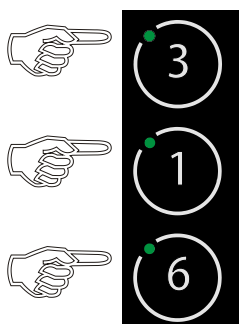

- Press the active line buttons once more to terminate the calls

When the calls terminate, the LEDs will stop lighting.

3.5 Emergency Public Address (ETB-100A only)

In order to comply with PA requirements, the system is designed with a minimum of two PA call stations. The configuration comprises an ETB-100A central unit with and call stations VMP-603 or VMT-603. The operation will mute the General Alarm system and override Talk-Back and single PA calls.

The ETB-100A central unit has 1st priority and will override PA call stations 2 and 3.

PA Call Stations Configuration with Gooseneck Microphone

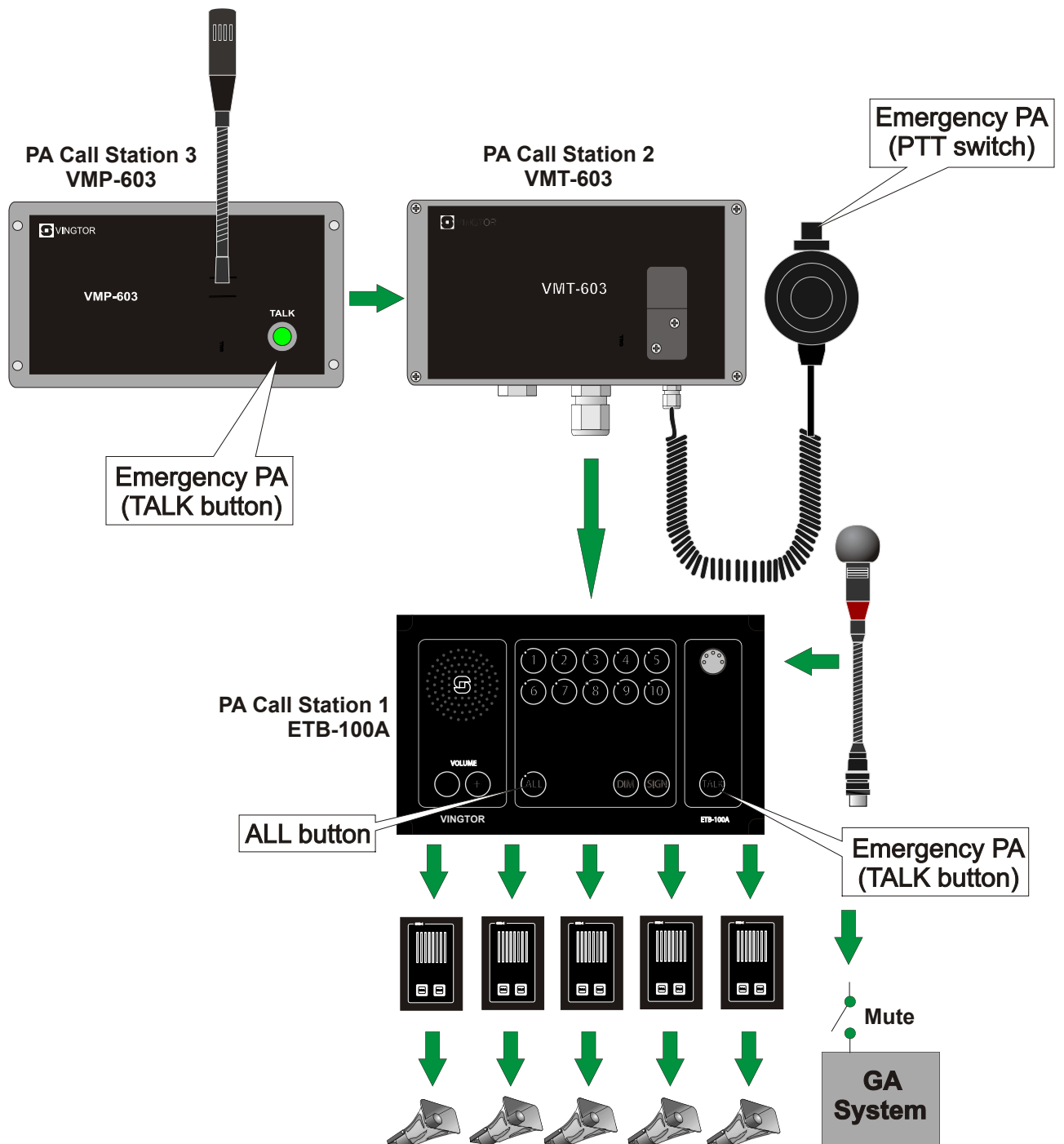

PA Call Stations Configuration with Handheld Microphone

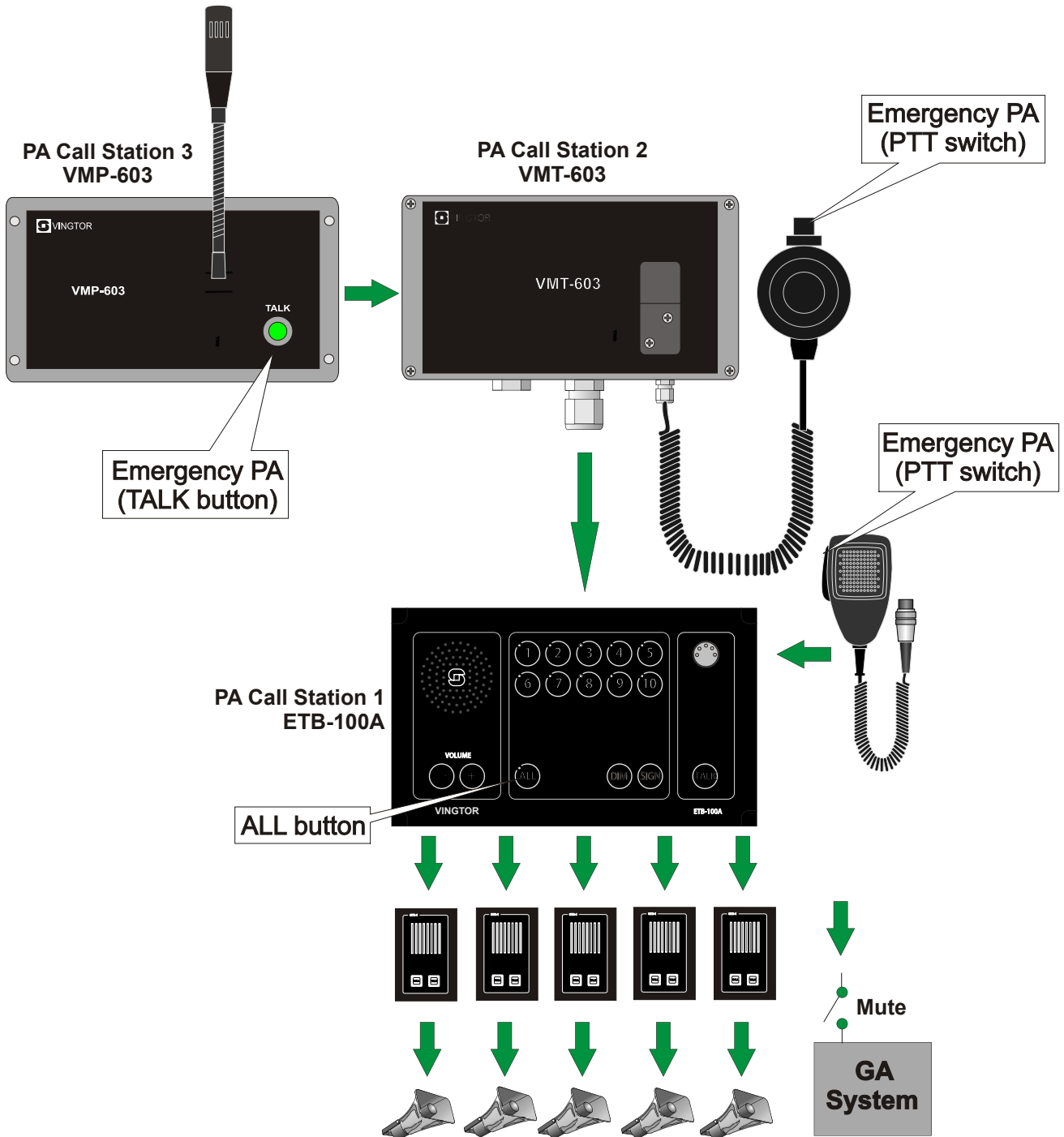

3.5.1 Operation from PA Call Station 1 - ETB-100A



- Press the ALL button
 - the call is set up indicated by a steady green LED in the ALL button

ETB central unit with gooseneck microphone MB-30G



- Press the **TALK** button for Emergency PA
 - The operation will mute the General Alarm system and override Talk-Back and single PA calls. The ETB-100A central unit has 1st priority and will override ongoing PA calls from station 2 (VMT-603).
- Speak clearly into the microphone.

ETB central unit with handheld microphone ETC-1-TB

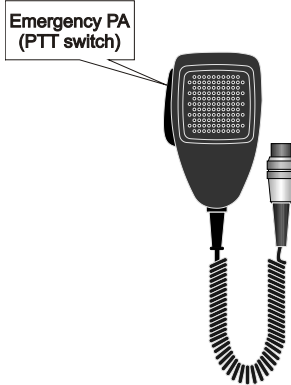

- Press the PTT switch for Emergency PA
 - The operation will mute the General Alarm system and override Talk-Back and single PA calls. The ETB-100A central unit has 1st priority and will override ongoing PA calls from station 2 (VMT-603).
- Speak clearly into the microphone

- Press the ALL button once more to terminate the PA call

When the call terminates, the LED will stop lighting.

3.5.2 Operation from PA Call Station 2 - VMT-603

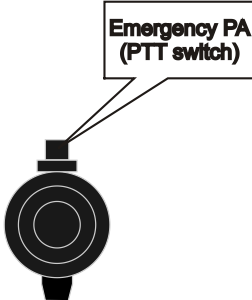

- Press the PTT switch for Emergency PA
 - The operation will mute the General Alarm system and override Talk-Back and single PA calls. The ETB-100A central unit has 1st priority and will override ongoing PA calls from station 2 (VMT-603).
- Speak clearly into the microphone

When the PTT switch is released, the ETB-100A central unit will revert to normal Talk-Back mode.

3.5.3 Operation from PA Call Station 3 - VMP-603



- Press the **TALK** button for Emergency PA
 - The operation will mute the General Alarm system and override Talk-Back and single PA calls. The ETB-100A central unit has 1st priority and will override ongoing PA calls from station 3 (VMP-603).
- Speak clearly into the microphone

When the **TALK** button is released, the ETB-100A central unit will revert to normal Talk-Back mode.

3.6 Operation from Substations

Calls can be made from substations to the ETB central unit by pressing the **CALL** button. A call is indicated by a flashing green LED and a signal in the ETB central unit. The call is confirmed when the respective line button is pressed. Only the ETB central unit can terminate the call.

3.6.1 Operation from Substation STB-1

Ingress Protection Rating = IP44

Substation STB-1

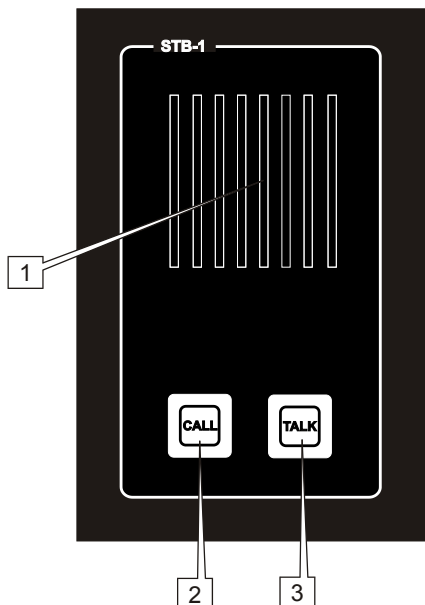

1. Re-entrant **Loudspeaker**
 - For communication from central unit
 - Microphone for communication to central unit
2. **CALL**
 - Push button switch for call to central unit
3. **TALK**
 - PTT switch for talk to central unit



Substation	Operation	ETB Central Unit
	<ul style="list-style-type: none"> • Press the CALL button <ul style="list-style-type: none"> - Indicated by flashing green LED for substation line and a signal in the ETB panel loudspeaker. • Operator of the ETB presses the respective line button has a flashing green LED <ul style="list-style-type: none"> - the call is set up, indicated by a steady green LED 	
 <p>Loudspeaker</p>	<ul style="list-style-type: none"> • Press the TALK button • Speak clearly into the re-entrant loudspeaker. <ul style="list-style-type: none"> - When TALK button is released, the STB-1 will be in listening mode and you will hear the communication from the ETB central unit. • Operator of the ETB central unit terminates the call by pressing the line button once more. 	

3.6.2 Operation from Substation STB-2

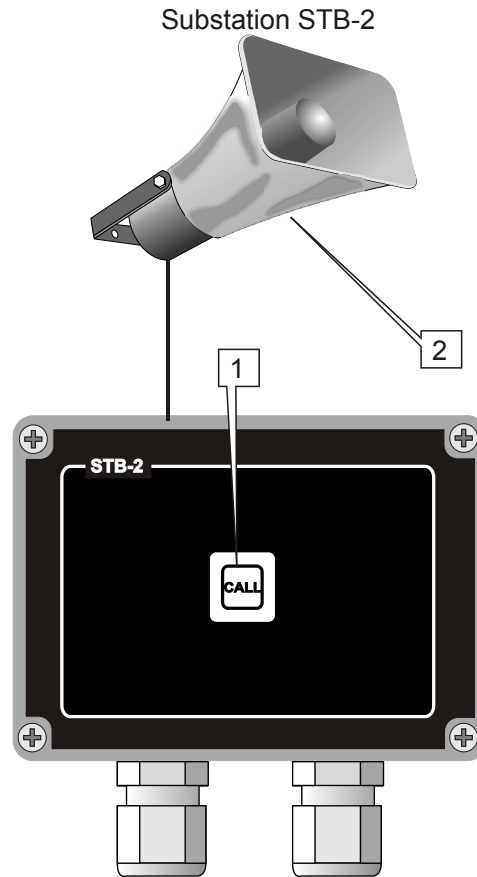
Ingress Protection Rating = IP66

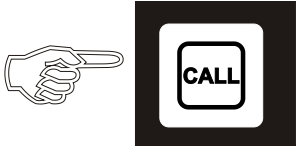
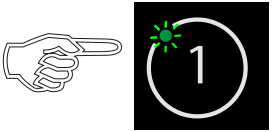
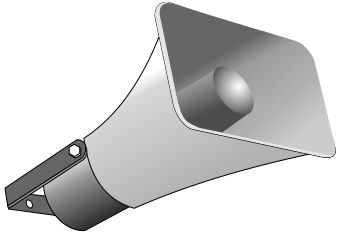

1. **CALL**
 - Push button for calling central unit.
2. **Re-entrant Loudspeaker**
 - Speaker receiving communication from central unit
 - Microphone for communication to central unit.

Substation	Operation	ETB Central Unit
	<ul style="list-style-type: none"> • Press the CALL button <ul style="list-style-type: none"> - Indicated by flashing green LED for substation line and a signal in the ETB panel loudspeaker. • Operator of the ETB presses the respective line button and the call is set up. <ul style="list-style-type: none"> - Indicated by steady green light in ETB 	
 <p>Loudspeaker</p>	<ul style="list-style-type: none"> • Speak clearly into the re-entrant loudspeaker of STB-2. <ul style="list-style-type: none"> - The same loudspeaker is used to send and receive communication to/from ETB. • Operator of the ETB central unit terminates the call by pressing the line button once more. 	



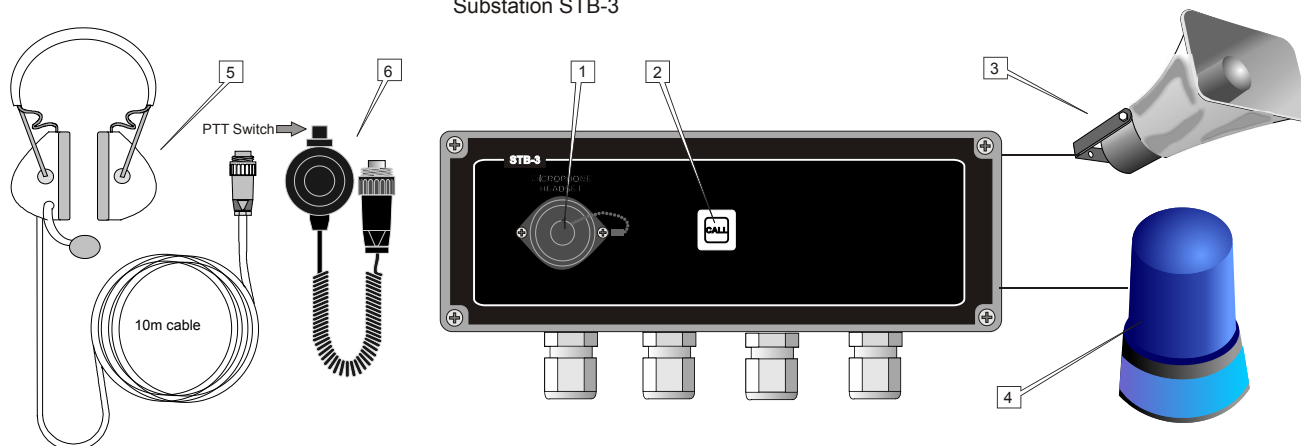

3.6.3 Operation from Substation STB-3

Ingress Protection Rating = IP66

Substation STB-3

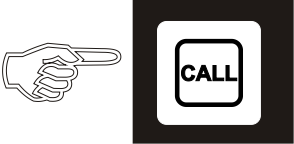
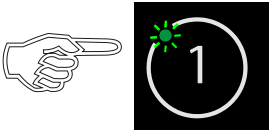
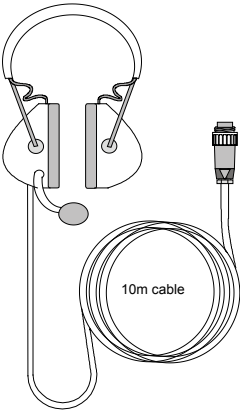

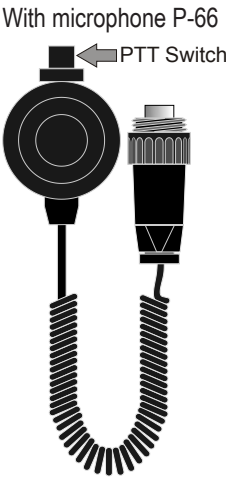
1. **Connector:** For headset or microphone
2. **CALL:** Push button for calling central unit
3. **Loudspeaker:** For receiving communication from central unit
4. **Signal device:** Activated from central unit
5. **Headset:** P-MT7 with boom microphone
6. **Microphone:** P-66 with PTT switch

Substation	Operation	ETB Central Unit
	<ul style="list-style-type: none"> • Press the CALL button <ul style="list-style-type: none"> - Indicated by flashing green LED for substation line and a signal in the ETB panel loudspeaker. • Operator of the ETB presses the respective line button, setting up the call. <ul style="list-style-type: none"> - Indicated by steady green light in ETB 	
<p>With headset P-MT7</p> 	<ul style="list-style-type: none"> • Speak clearly into the boom microphone on the headset. <ul style="list-style-type: none"> - Receive communication from the ETB central unit in the headphones (and in the loudspeaker if installed) • Operator of the ETB central unit terminates the call by pressing the line button once more. 	
<p>With microphone P-66</p> 	<ul style="list-style-type: none"> • Press the PTT switch on the microphone. • Speak clearly into the microphone. <ul style="list-style-type: none"> - When the PTT switch is released, the microphone will be in listening mode and you will hear the communication from the ETB central unit in the loudspeaker • Operator of the ETB central unit terminates the call by pressing the line button once more. 	

3.6.4 Operation from Substation STB-5

Ingress Protection Rating = IP44
Substation STB-5

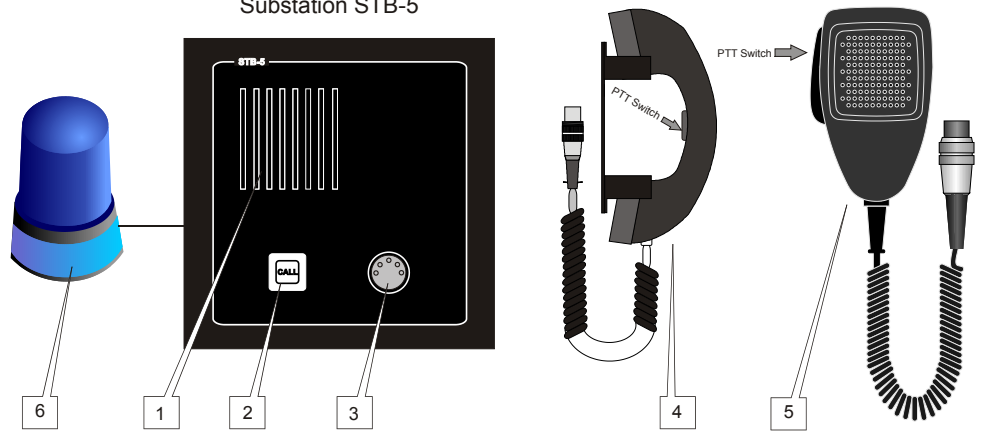

1. **Loudspeaker** : For communication from central unit
2. **CALL** : Push button for calling central unit
3. **Connector** : For handset HAS-1 or microphone ETC-STB5
4. **Handset** : HAS-1 with PTT switch
5. **Microphone** : ETC-STB5 with PTT switch
6. **Signal device** : Activated from central unit







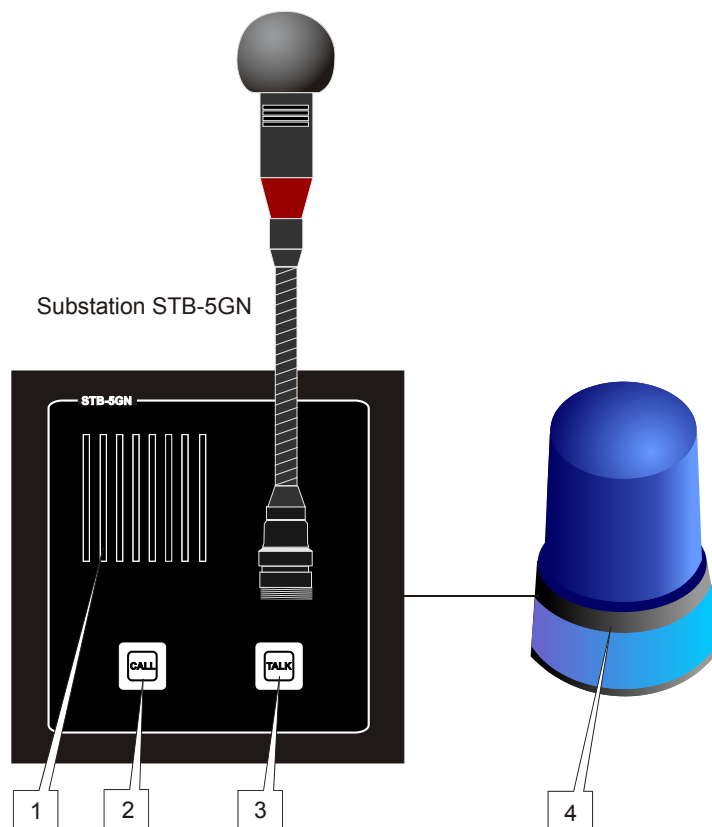

Substation	Operation	ETB Central Unit
	<ul style="list-style-type: none"> Press the CALL button <ul style="list-style-type: none"> Indicated by flashing green LED for substation line and a signal in the ETB panel loudspeaker. Operator of the ETB presses the respective line button, setting up the call <ul style="list-style-type: none"> Indicated by steady green light in ETB 	
<p>With microphone ETC-1-B ETC-1-TB</p>	<ul style="list-style-type: none"> Press the PTT switch on the microphone. Speak clearly into the microphone. <ul style="list-style-type: none"> When the PTT switch is released, the STB-5 will be in listening mode and you will hear the communication in the panel loudspeaker Operator of the ETB central unit terminates the call by pressing the line button once more. 	
<p>With handset HAS-1</p>	<ul style="list-style-type: none"> Press the PTT switch on the handset. Speak clearly into the handset. <ul style="list-style-type: none"> When the PTT switch is released, the STB-5 will be in listening mode and communication from the ETB comes from the handset's speaker Operator of the ETB central unit terminates the call by pressing the line button once more. 	
	<ul style="list-style-type: none"> Speak clearly into the re-entrant loudspeaker of STB-5. <ul style="list-style-type: none"> The same loudspeaker is used to send and receive communication to/from ETB. Operator of the ETB central unit terminates the call by pressing the line button once more. 	

3.6.5 Operation from Substation STB-5GN

Ingress Protection Rating = IP44



1. **Loudspeaker** : For communication from central unit
2. **CALL** : Push button for calling central unit
3. **TALK** : PTT switch for talking to central unit
4. **Signal device** : Activated from central unit

Substation	Operation	ETB Central Unit
 	<ul style="list-style-type: none"> • Press the CALL button <ul style="list-style-type: none"> - Indicated by flashing green LED for substation line and a signal in the ETB panel loudspeaker. • Operator of the ETB presses the respective line button and the call is set up. <ul style="list-style-type: none"> - Indicated by steady green light in ETB 	 
  	<ul style="list-style-type: none"> • Press the TALK button on the STB-5GN • Speak clearly into the microphone <ul style="list-style-type: none"> - When TALK button is released, the STB-5GN will be in listening mode and you will hear the communication the panel speaker. • Operator of the ETB central unit terminates the call by pressing the line button once more. 	 

3.6.6 Operation from Substation HE-112M / HE-112M-T

Ingress Protection Rating = IP66

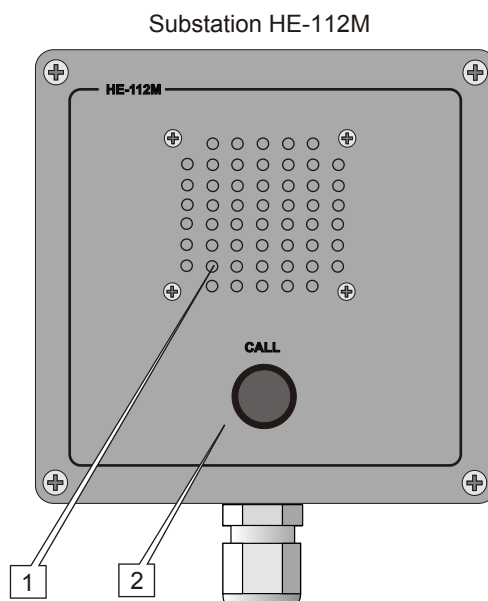

1. **Re-entrant Loudspeaker**
 - Speaker for communication from central unit
 - Microphone for communication to central unit
2. **CALL**
 - Push button for calling central unit

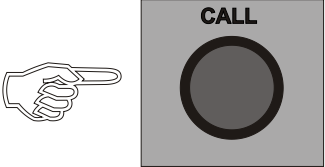
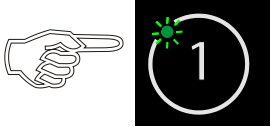
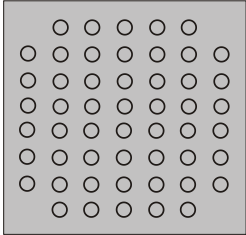
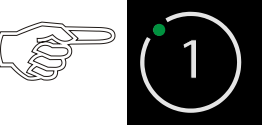
Substation	Operation	ETB Central Unit
	<ul style="list-style-type: none"> • Press the CALL button <ul style="list-style-type: none"> - Indicated by flashing green LED for substation line and a signal in the ETB panel loudspeaker. • Operator of the ETB presses the respective line button and the call is set up. <ul style="list-style-type: none"> - Indicated by steady green light in ETB 	
	<ul style="list-style-type: none"> • Speak clearly into the re-entrant loudspeaker of HE-112M/HE-112M-T <ul style="list-style-type: none"> - The same loudspeaker is used to send/receive communication to/from ETB. • Operator of the ETB central unit terminates the call by pressing the line button once more. 	

3.6.7 Operation from Substation VH-10M / VH-10M-T

Ingress Protection Rating = IP65

Substation VH-10M

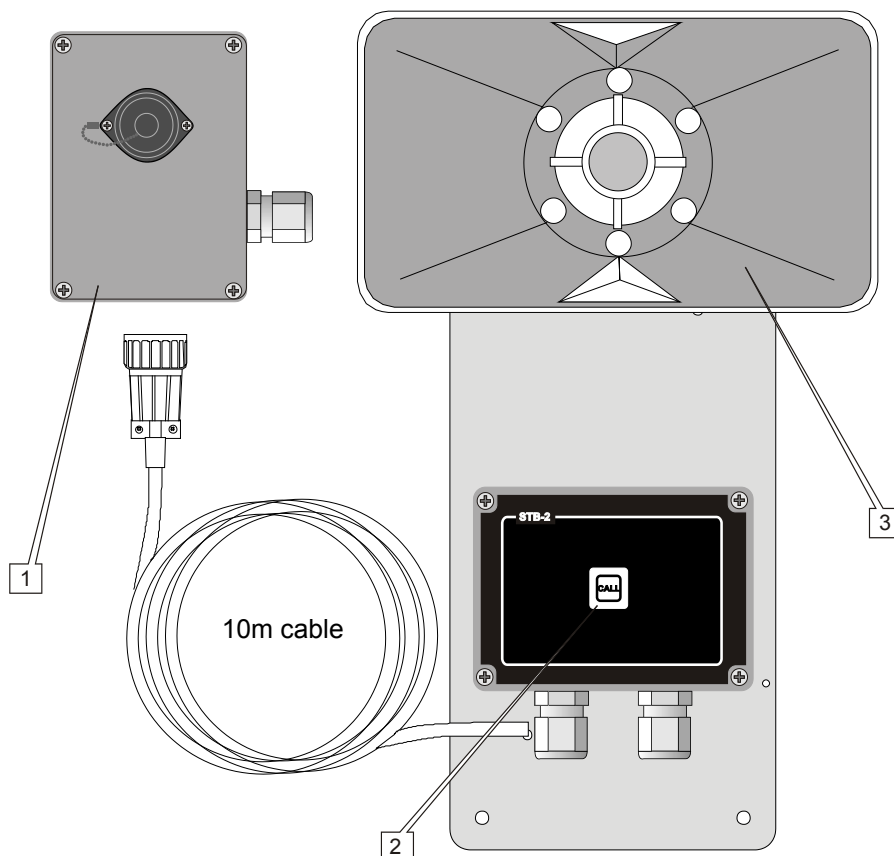

1. Plugbox

- CD-2 for VH-10M





2. CALL

- Push button for calling central unit

3. Re-entrant Loudspeaker

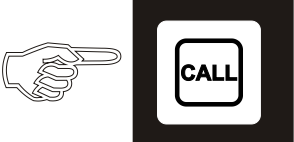
- Speaker for communication from central unit

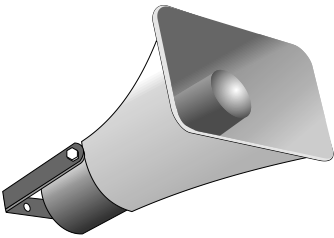
- Microphone for communication to central unit



Substation	Operation	ETB Central Unit
	<ul style="list-style-type: none"> Press the CALL button <ul style="list-style-type: none"> Indicated by flashing green LED for substation line and a signal in the ETB panel loudspeaker. Operator of the ETB presses the respective line button and the call is set up. <ul style="list-style-type: none"> Indicated by steady green light in ETB 	
	<ul style="list-style-type: none"> Speak clearly into the re-entrant horn speaker of VH-10M/VH-10M-T <ul style="list-style-type: none"> The same loudspeaker is used to send/receive communication to/from ETB. Operator of the ETB central unit ends the call by pressing the line button once more. 	

3.6.8 Operation from Substation VHM-10 / VHM-10-T

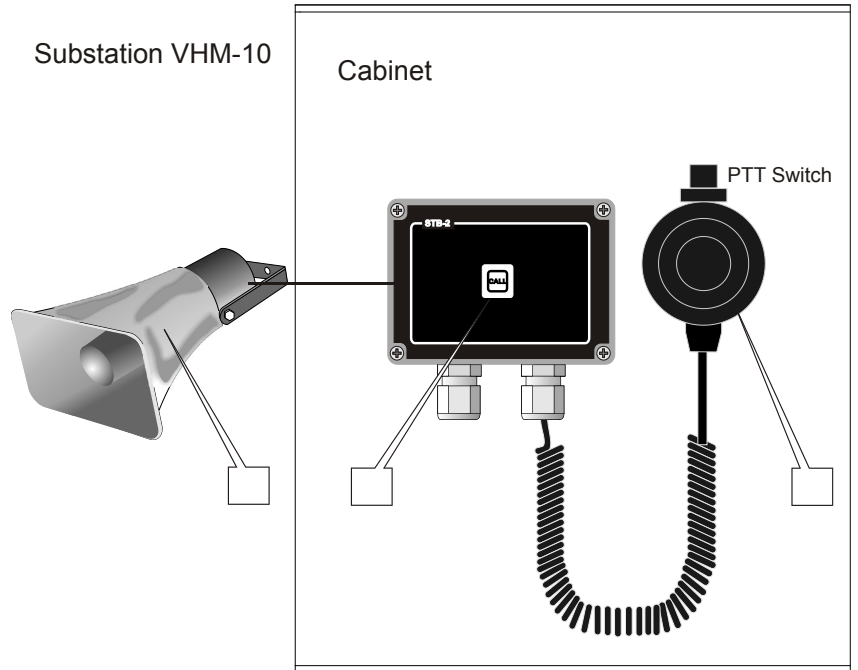
Ingress Protection Rating = IP66

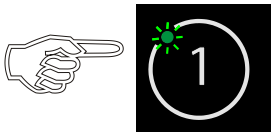
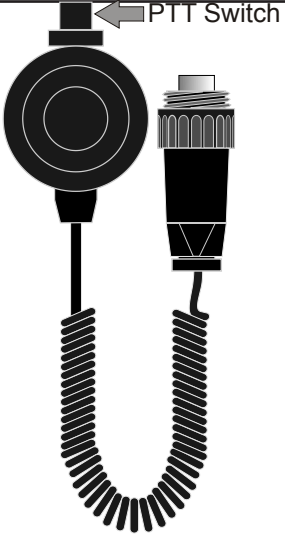

1. **Loudspeaker** : For communication from central unit
2. **CALL** : Push button for calling central unit
3. **Microphone** : P-66 fixed connected with PTT switch

Substation	Operation	ETB Central Unit
	<ul style="list-style-type: none"> • Press the CALL button <ul style="list-style-type: none"> - Indicated by flashing green LED for substation line and a signal in the ETB panel loudspeaker. • Operator of the ETB presses the respective line (1-10) button and the call is set up. <ul style="list-style-type: none"> - Indicated by steady green light in ETB 	
	<ul style="list-style-type: none"> • Press the PTT switch on the microphone. • Speak clearly into the microphone. <ul style="list-style-type: none"> - When the PTT switch is released, the VHM-10/VHM-10-T will be in listening mode and you will hear the communication in the loudspeaker • Operator of the ETB central unit ends the call by pressing the line button once more. 	



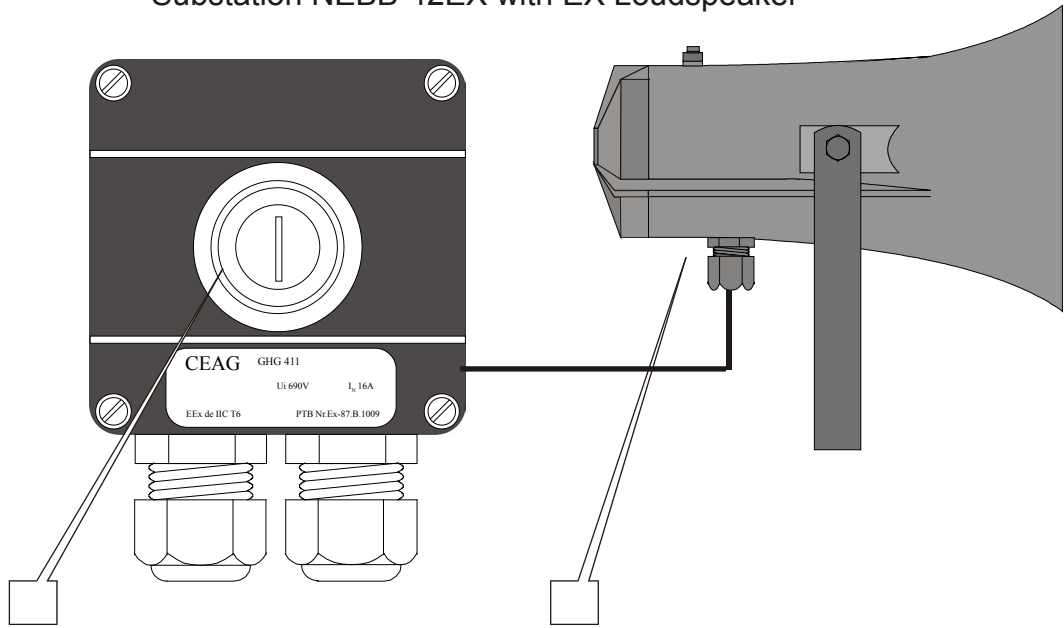

3.6.9 Operation from Substation NEBB-42EX

Ingress Protection Rating = IP67

Substation NEBB-42EX with EX Loudspeaker

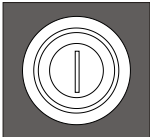

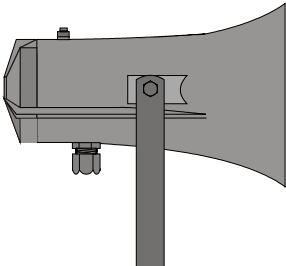
1. Call button
2. Re-entrant EX Loudspeaker

Substation	Operation	ETB Central Unit
 	<ul style="list-style-type: none"> • Press the call button <ul style="list-style-type: none"> - Indicated by flashing green LED for substation line and a signal in the ETB panel loudspeaker. • Operator of the ETB presses the respective line (1-10) button and the call is set up. <ul style="list-style-type: none"> - Indicated by steady green light in ETB 	 
	<ul style="list-style-type: none"> • Speak clearly into the re-entrant EX loudspeaker <ul style="list-style-type: none"> - The same loudspeaker is used to send/receive communication to/from ETB. • Operator of the ETB central unit ends the call by pressing the line button once more. 	 

4 Commissioning

4.1 General

The ETB central unit and all subsidiary equipment have been fully tested in our workshop before delivery.

To ensure that the system operates correctly after installation and configuration, carry out the following procedures before using the system.

4.2 Mechanical Inspection

- All equipment is well fastened in the console or wall.
- All cable and cable glands are well tightened and fastened.

4.3 Cable Inspection

All cables are connected according to cable connection diagrams in Section 7.

- All signal cables have to be min. 0.75 mm², approved ship cable of type twisted-pair with outer braided copper screen
- Terminal block on main board K1 – K10 /no. 5 is ground point for each substation
- Power cable is 0.75 mm² and connected to terminal block K11 (+ to terminal 1, - to terminal 2)
- The screen is grounded on terminal 3
- 0.75 mm² cable is used for power to signal units
- Polarity for extra signal device is connected according to cable connection diagrams in Section 7.

4.4 Check Configurations

For microphones

Jumper **J1** on the keyboard PCB has to be set to **Microphone**.

For ETB central unit with foot switch

The jumper marked **jumper for foot switch** on the main board has to be removed.

Public address operation

Jumpers **J12** to **J21** for each line (on ETB-100 board) have to be set in position **PA**.

Substation default settings

To change the default settings for substation STB-1, STB-3, and STB-5, see sections 2.12, 2.13, 2.14.

Maximum load

Maximum load of directly connected extra signal device or substation with relay is 50 mA.

Maximum load of substation with relay is 2A.

4.5 Identification Labels

- A identification label with directory/extension number for all substations should be placed close to the ETB central unit.

- A sign plate with each substation number should be placed on or close to each substation.

4.6 Starting Up the System

The system has no On/Off switch for main power. Once it is plugged in, the system powers up and is ready for use. Indications that the system is powered up are the fact that button backlight is lit and the buttons can be activated.

4.7 Functions Test Procedure

The following procedures have to be carried out before using the system. Carry out the test procedures for all equipment in the installation.

Basic Functions of ETB central unit

1. Carry out Commissioning according to sections 4.2, 4.3, 4.4 and 4.5
2. Power on ETB, 24V DC measured on terminal K11 no. 1-2
3. Power on 100V amplifier, 230V AC, indicated by green LED (ETB-100/ETB-100A)
4. Make a call to each substation. (section 3.1.1)
5. Make a call to a group of substations. (section 3.1.2)
6. Make All Call (section 3.1.3)
7. Give signal to substations with extra signal device. (section 3.1.5)
8. Receive a Call from an substation (section 3.1.6)
9. Receive a Call from two or more substations. (section 3.1.7)
10. Volume control of internal loudspeaker on ETB panel
11. Dimmer for light in Line button

Additional Functions ETB (if installed)

1. Make a handsfree call with foot switch. (section 3.1.4)
2. Simple Public Address Operation (ETB-100A). (section 3.4)
3. Emergency Public Address Operation (ETB-100A). (section 3.5)

Parallel Communication / Bridge Wing (section 3.2.1)

1. Operation with STB-6
2. Operation with STB-6GN
3. Operation with STB-6GN handsfree
4. Operation with SB-4
5. Call to two or more substations from parallel station

Power Supply SPS-4 (if installed)

1. Operating with 230V AC or 115V AC mains power supply. On terminals 3-4, check that green LED labeled **DC OK** is lit.
2. Operating with 24V DC emergency power supply.
 - Disconnect 230V AC or 115V AC mains power supply and check if the auto switch relay switches over to emergency 24V DC. On

terminals 3-4, check that power failure contact labeled NC 6-7 is activated.

- Disconnect cables to + and – on the power supply module and check if the auto switch relay switches over to emergency 24V DC. On terminals 3-4, check that power failure contact labeled NC 6-7 is activated.

Substations

1. Operation from STB-1 (section 3.6.1)
2. Operation from STB-2 (section 3.6.2)
3. Operation from STB-3 (section 3.6.3)
4. Operation from STB-5 (section 3.6.4)
5. Operation from STB-5GN (section 3.6.5)
6. Operation from HE-112M/HE-112M-T (section 3.6.6)
7. Operation from VH-10M/VH-10M-T (section 3.6.7)
8. Operation from VHM-10/VHM-10-T (section 3.6.8)
9. Operation from NEBB-42EX / EX Loudspeaker (section 3.6.9)

Volume Control

- Adjust sound pressure level to convenient level if necessary for master volume lines 1-5 and 6-10.
 - See section 2.6 and drawings in *Section 7*

5 Troubleshooting

① *Use the troubleshooting procedures together with Section 2 Installation & Configuration Procedures.*

Problems When Operating from ETB Central Unit		
Issue/Failure	Description/Indication	Recommended Action
The whole system has shut down. No light indication in ETB panel.	<ol style="list-style-type: none"> 1. No voltage measured on terminal block K11 no.1-2. 2. Correct voltage 24 – 32VDC measured on terminal block K11 no.1-2. 	<ol style="list-style-type: none"> 1. Check 24V DC mains power supply or power supply SPS-4. 2. Check fuse marked S1 2AT and S2 1AT (see PCB Layout drawings in Section 7)
SPS-4 power supply failure	Indication from failure contact X2 No. 5-6(NO) or X2 No.6-7 (NC). No light in "DC OK". Due to two possibilities: <ol style="list-style-type: none"> 1. 230V AC or 115V AC failed and has been switched to 24V DC emergency. 2. Power supply module has failed. 	<ol style="list-style-type: none"> 1. Check main power supply 2. Check fuse 5.0AT, terminal marked 3 <ul style="list-style-type: none"> - If not successful, the power module has to be repaired/replaced.
General operating problems in several stations.	System Instability	Check cable and termination blocks in the ETB panel for respective stations, and especially cable and termination blocks in junction boxes if in use.
One substation can not be operated.	No contact between ETB panel and substation	<ol style="list-style-type: none"> 1. Check cable and terminal block in the ETB panel for current extension. 2. Check cable and terminal block in the substation or plugbox. 3. Move this terminal block to another extension number. If operation on new extension is OK, the substation has to be repaired.
Operation problem from a substation.	Continuous beeping tone in the ETB central unit.	Change polarity in substation terminals no. 1-2
No signal in substation when using the SIGN button in the ETB central unit.	No audio 1 KHz tone in the substation.	<ol style="list-style-type: none"> 1. Disconnect the substation. 2. If 7V AC is measured on terminals 1-2 in the ETB central unit, this unit is OK. 3. If no voltage is measured, the ETB central unit has to be repaired 4. Connect the substation. <ul style="list-style-type: none"> - If no voltage is measured on terminals 1-2 in substation, the fault must be in cable or the substation has to be repaired.
No signal in additional signal device when using the SIGN button.	Signal in substation, but no signal in the additional signal device.	Disconnect the substation. <ol style="list-style-type: none"> 1. If no voltage is measured on terminals 3-4 in the ETB central unit, check fuse S2 1A. 2. If fuse S2 1A is OK, <ul style="list-style-type: none"> - check automatic fuse by waiting 2-3 seconds. If 24V DC is measured, the load is too high - Max. 50 mA
Feedback problems	Feedback from the ETB central unit	Move substation or parallel equipment to another position.
System generated noise 1	Occurring both in ETB central unit and substations when using own 24V DC power supply.	Disconnect 24V DC and connect a separate power supply (SPS-4) or a DC 24V / 24V DC converter.
System generated noise 2	Occurring both in ETB central unit and substations.	<ol style="list-style-type: none"> 1. Check all cable connections, especially the screens. It is important that connections are done according to requirements in Section 2.4 and connection diagrams in Section 7. 2. If problem persists, try using a capacitor 1uF between terminals no. 1-2 block K11. 3. If problem still persists, it will require service from Zenitel.

Problems When Operating from Substation or Parallel Station		
Issue/Failure	Description/Indication	Recommended Action
The substation can not be operated.	No flashing green LED nor signal in the ETB monitor loudspeaker for the selected line.	<ol style="list-style-type: none"> 1. Check cable and terminal block in the substation or plugbox. 2. Move this terminal block to another extension number. If problem persists, substation has to be repaired. If substation operation is OK, ETB central unit has to be repaired
High background sound.	Due to nearby substation.	<ol style="list-style-type: none"> 1. Replace current substation with substation with headset or with external loudspeaker STB-2. 2. Adjust master volume lines 1-5 in ETB-5 or 6-10 in ETB-10 (see PCB Layout drawings in Section 7).
Operation from a parallel station can not be done.	Operation is possible from ETB central unit.	<ol style="list-style-type: none"> 1. Check cable and connections between the parallel station and the ETB central unit. 2. Check microphones <ul style="list-style-type: none"> - If problem persists, the parallel station has to be repaired.

6 Dimension Drawings

All dimensions shown are in mm.

6.1 ETB-5

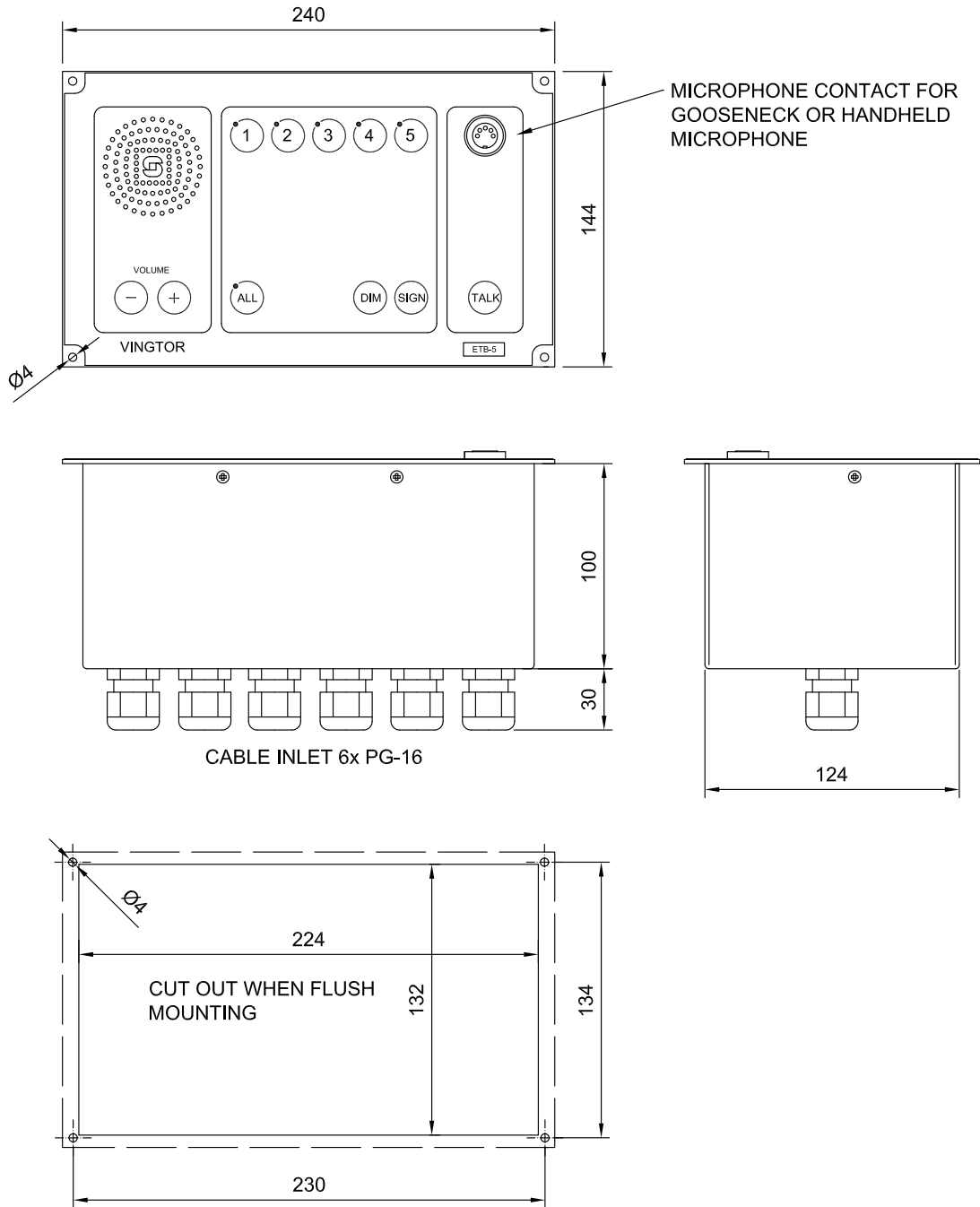

6.2 ETB-10/ETB-10A

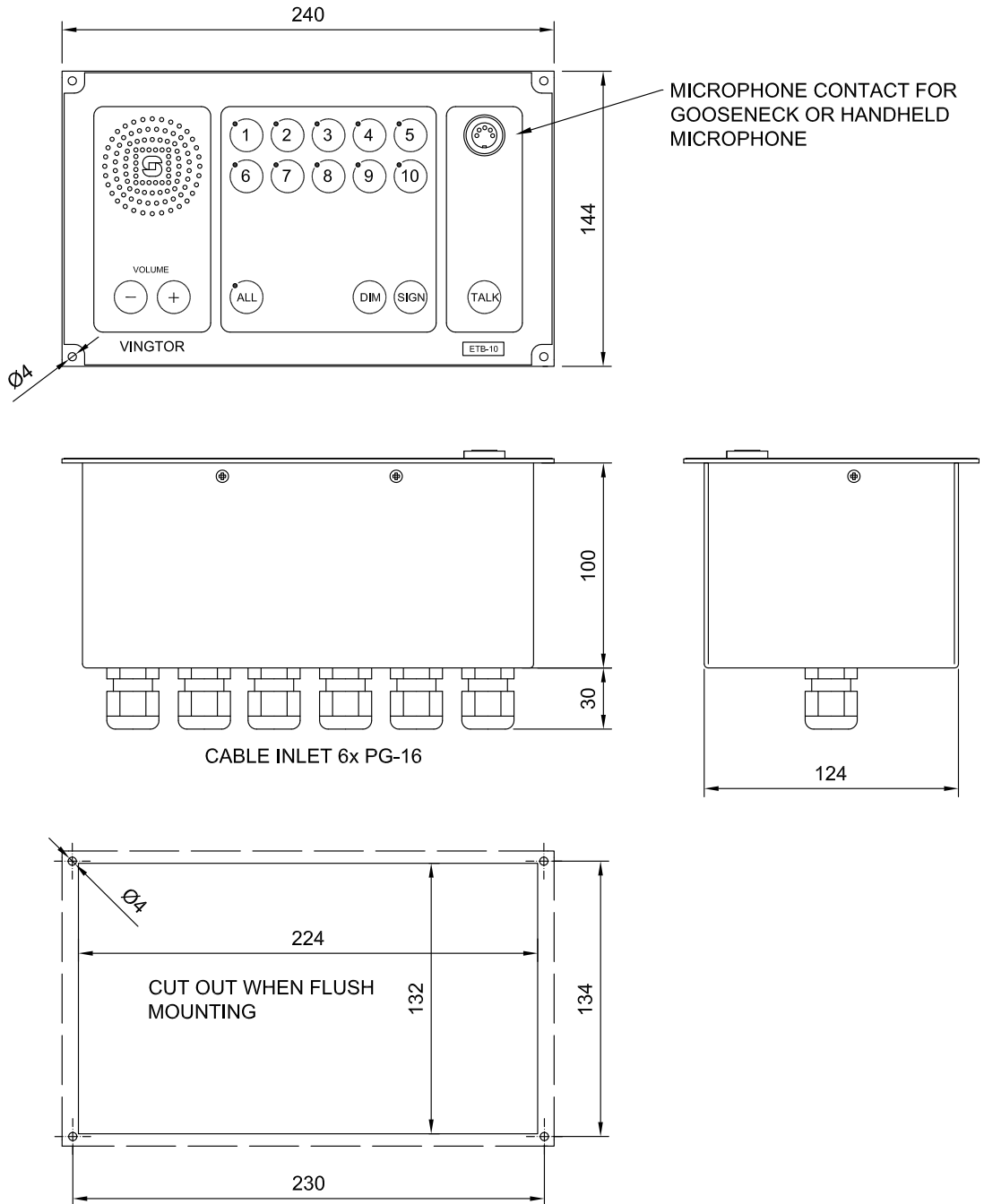

6.3 ETB-100/ETB-100A

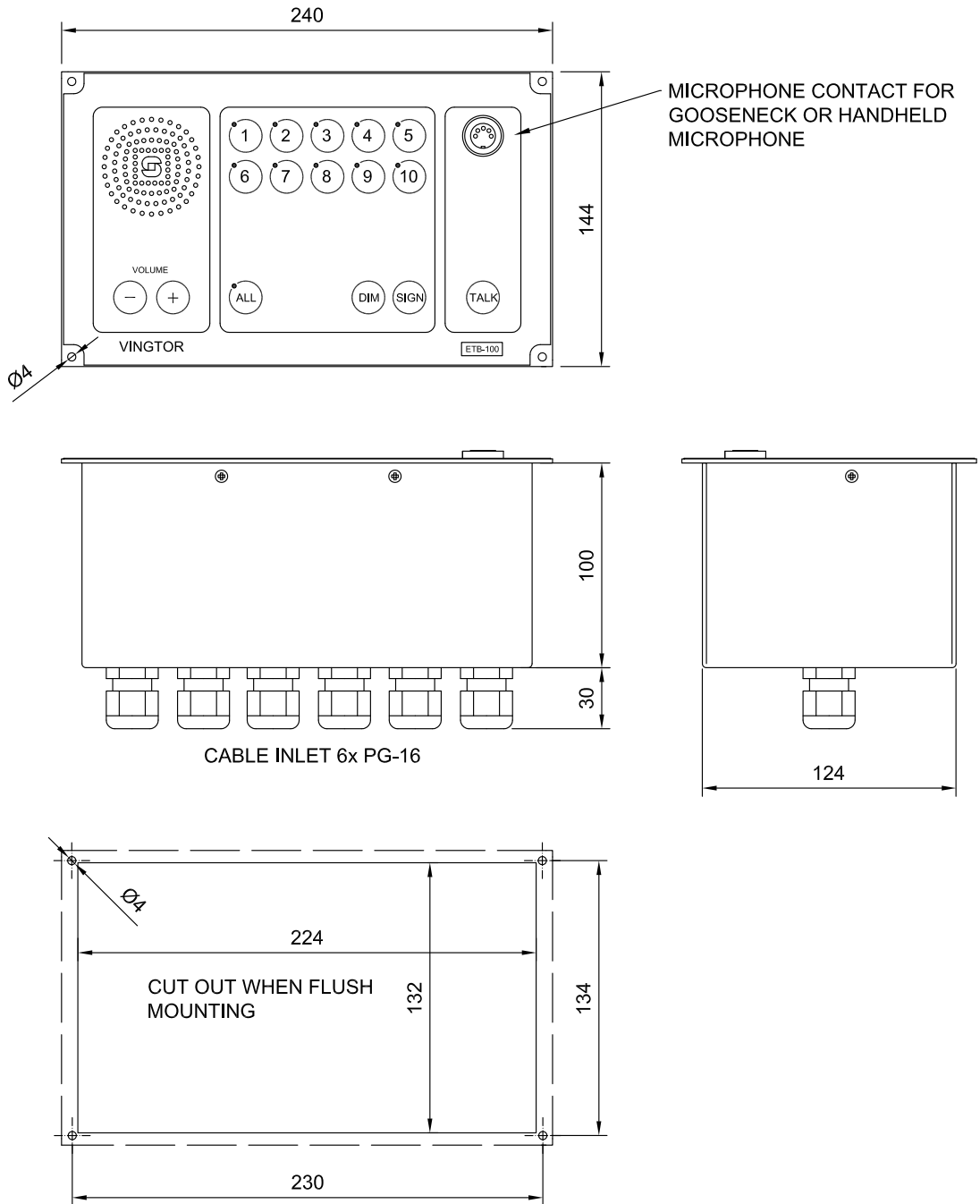

7 Connection/Block/Single Line Diagrams

7.1 ETB-100 Single Line Diagram

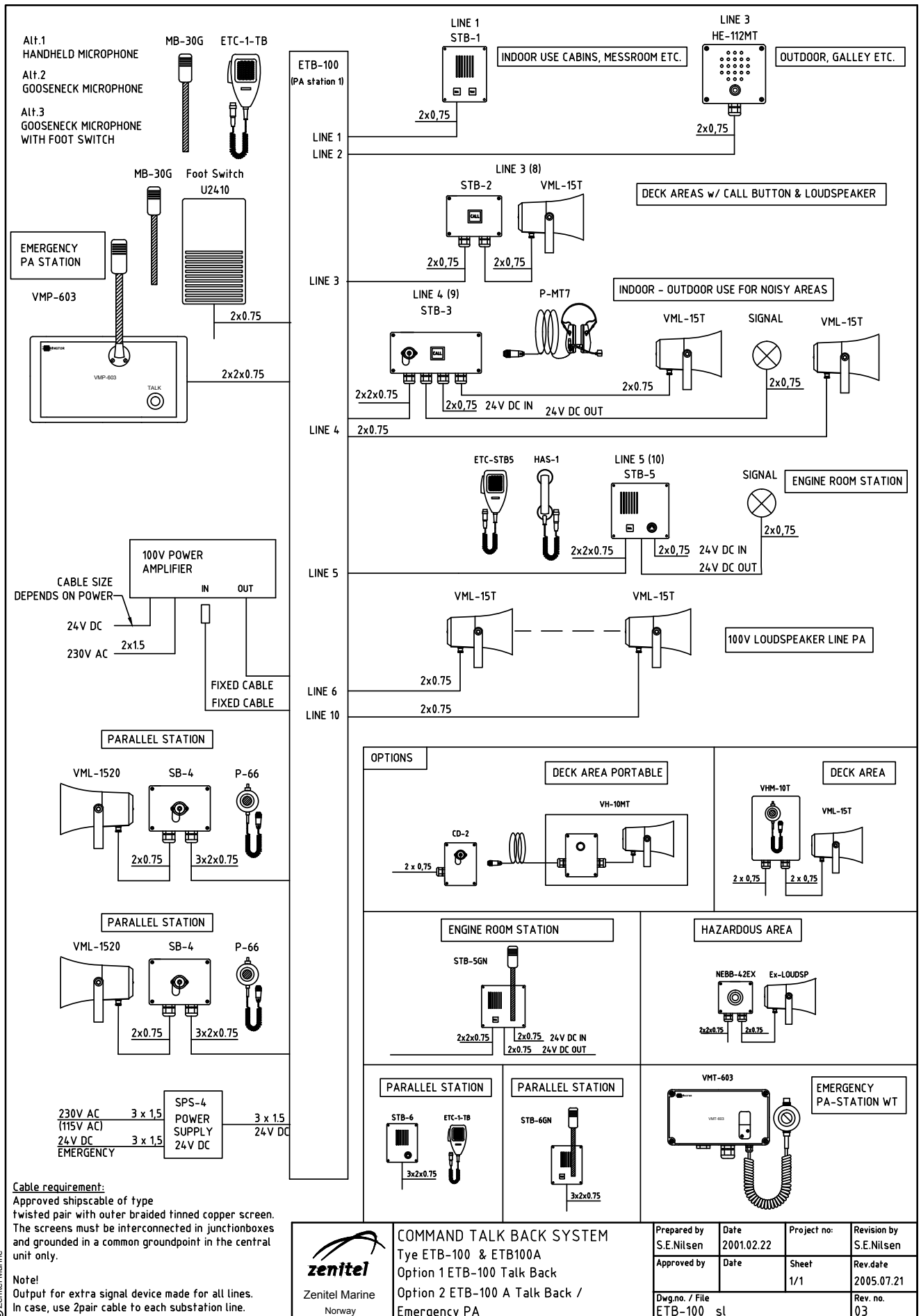

© Zenitel Marine



COMMAND TALK BACK SYSTEM
Tye ETB-100 & ETB100A
Option 1 ETB-100 Talk Back
Option 2 ETB-100 A Talk Back /
Emergency PA

Prepared by S.E.Nilsen	Date 2001.02.22	Project no:	Revision by S.E.Nilsen
Approved by	Date	Sheet 1/1	Rev.date 2005.07.21
Dwg.no. / File ETB-100_sl			Rev. no. 03

7.2 ETB-5/ETB-10 Single Line Diagram

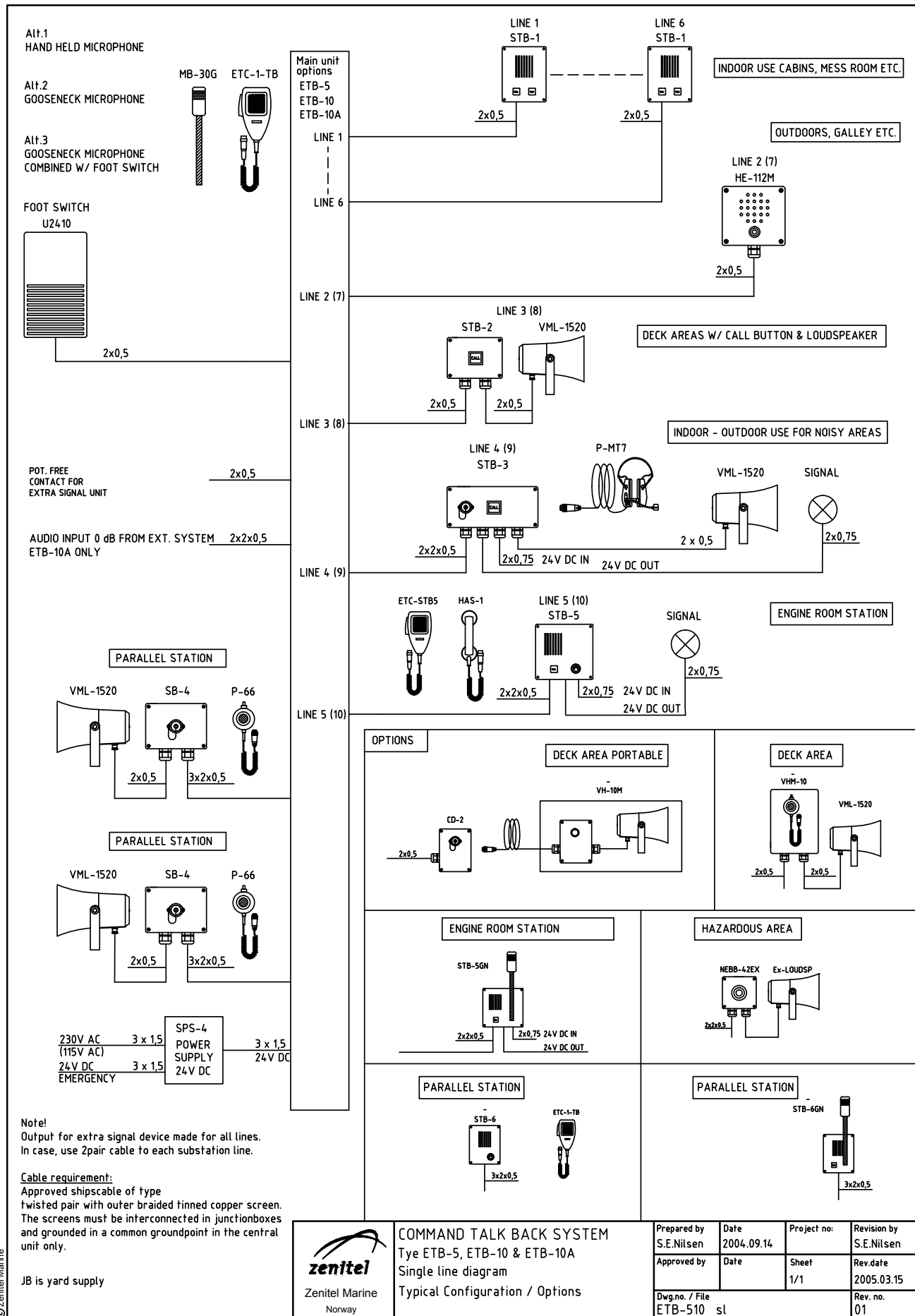



COMMAND TALK BACK SYSTEM
Tye ETB-5, ETB-10 & ETB-10A
Single line diagram
Typical Configuration / Options

Prepared by S.E.Nilsen	Date 2004.09.14	Project no:	Revision by S.E.Nilsen
Approved by	Date	Sheet 1/1	Rev.date 2005.03.15
Dwg.no. / File ETB-510_sl			Rev. no. 01

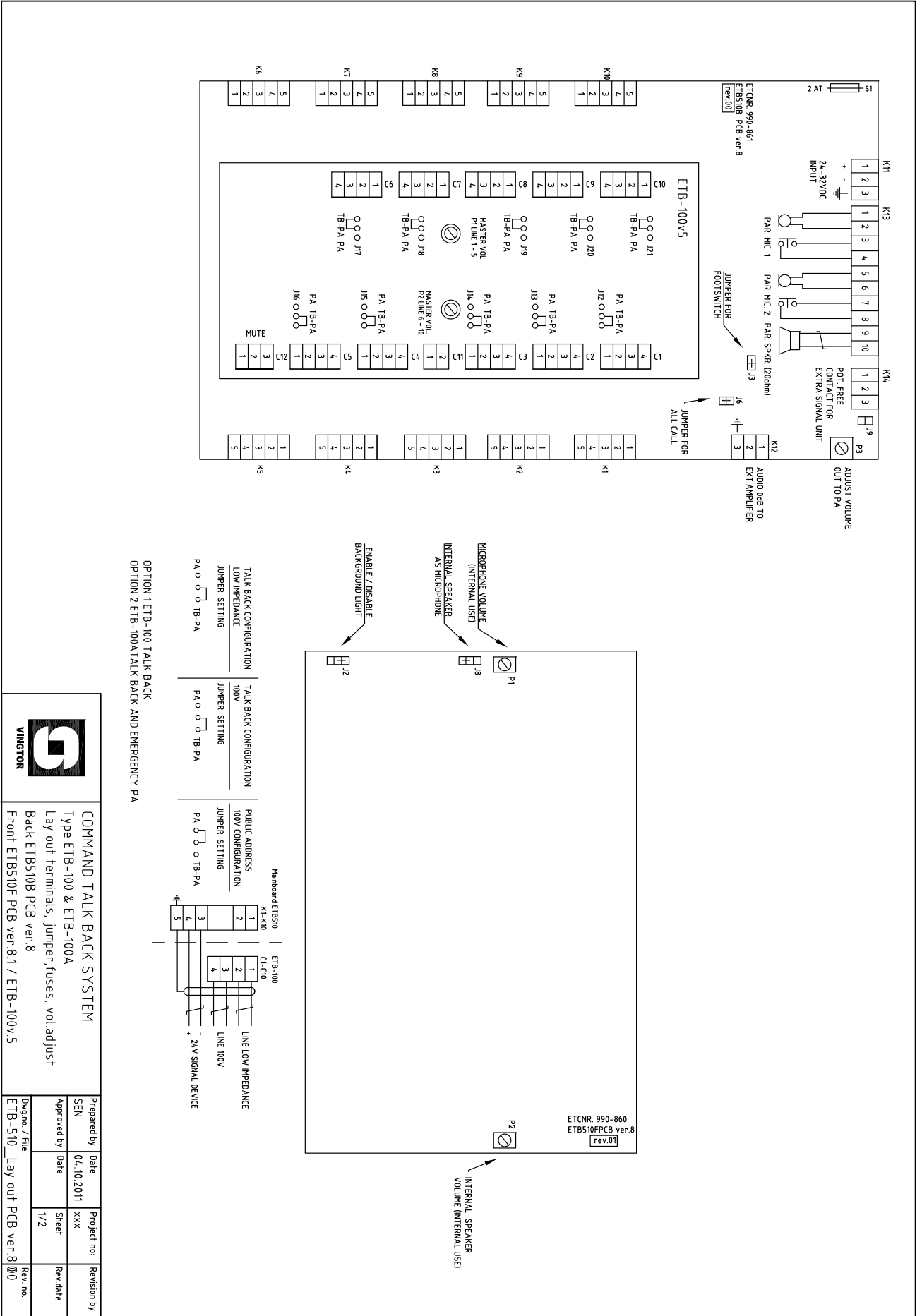
7.3 ETB-100 PCB Layout

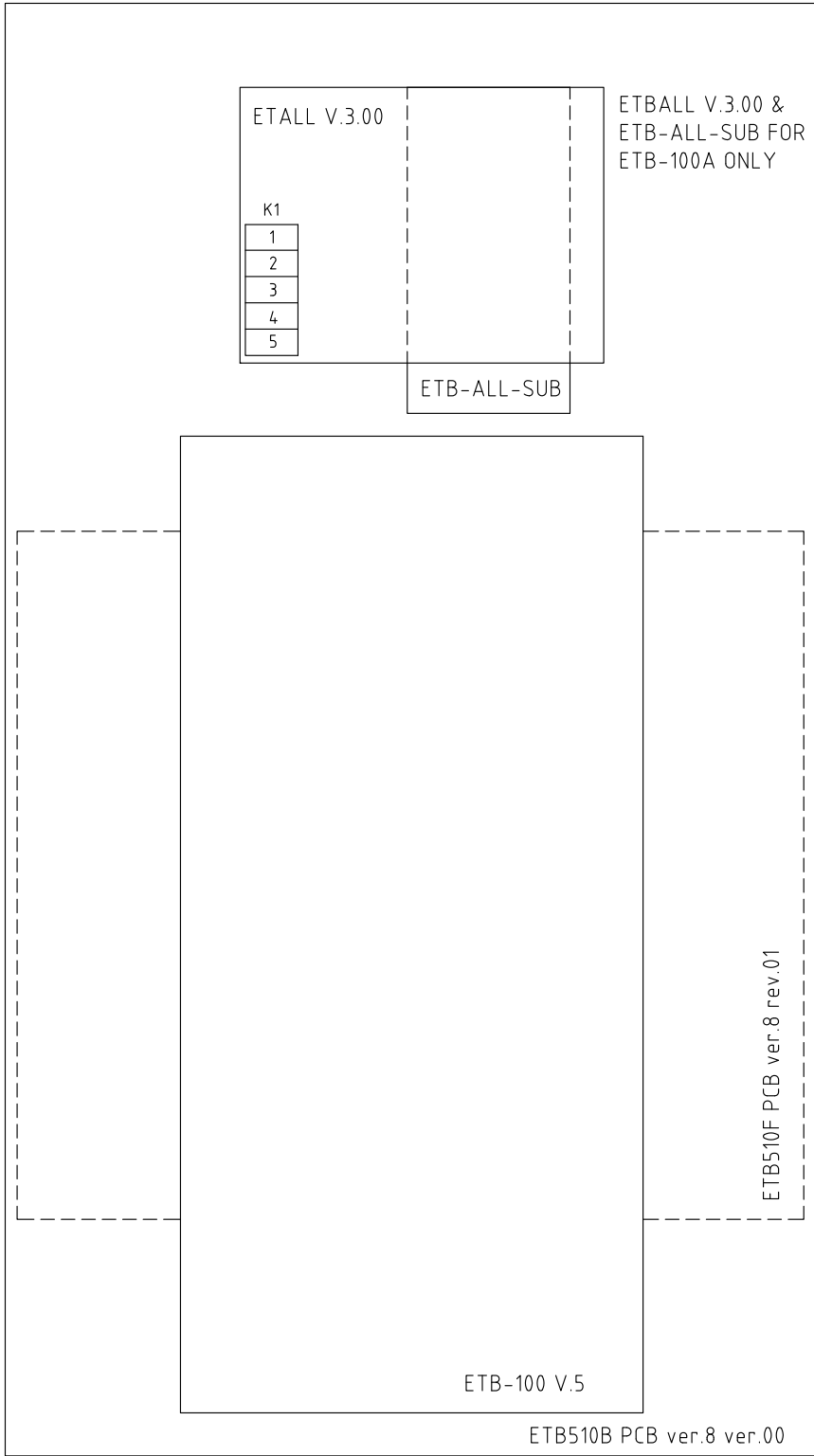



 VINGTOR	COMMAND TALK BACK SYSTEM Type ETB-100 & ETB-100A Lay out all PCB ETB510B PCB ver.8 ETB510F PCB ver.8.1 / ETB-100v.5 ETALL V3.00 / ETB-ALL-SUB				Prepared by SEN	Date 04.10.2011	Project no.	Revision by
	Approved by	Date	Sheet 2/2	Rev.date				
	Dwg.no. / File ETB-100_Lay out PCB ver.8			Rev. no. 00				

7.4 ETB-5/ETB-10 PCB Layout

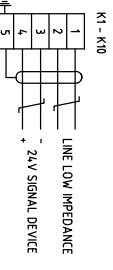
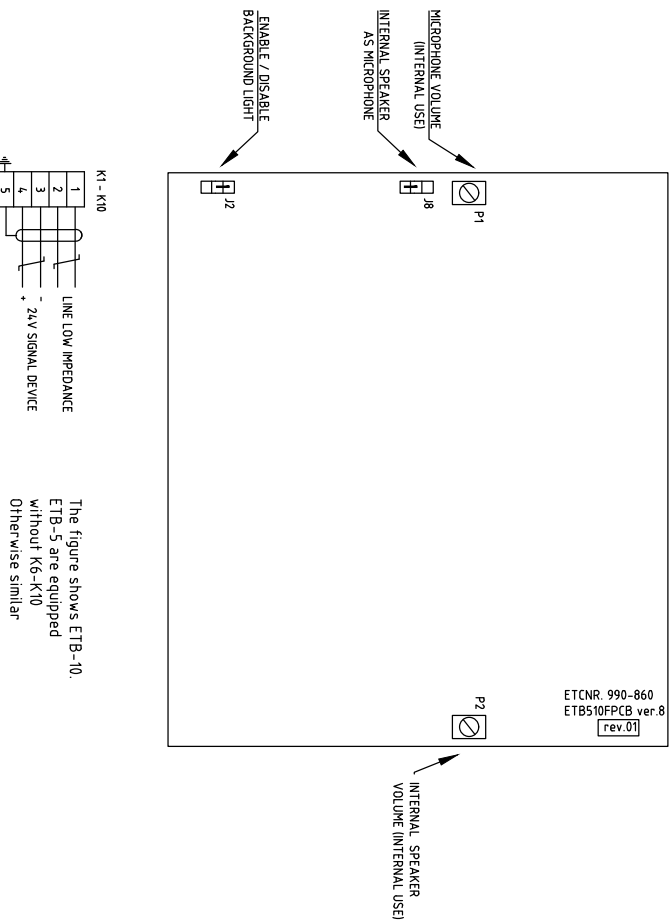
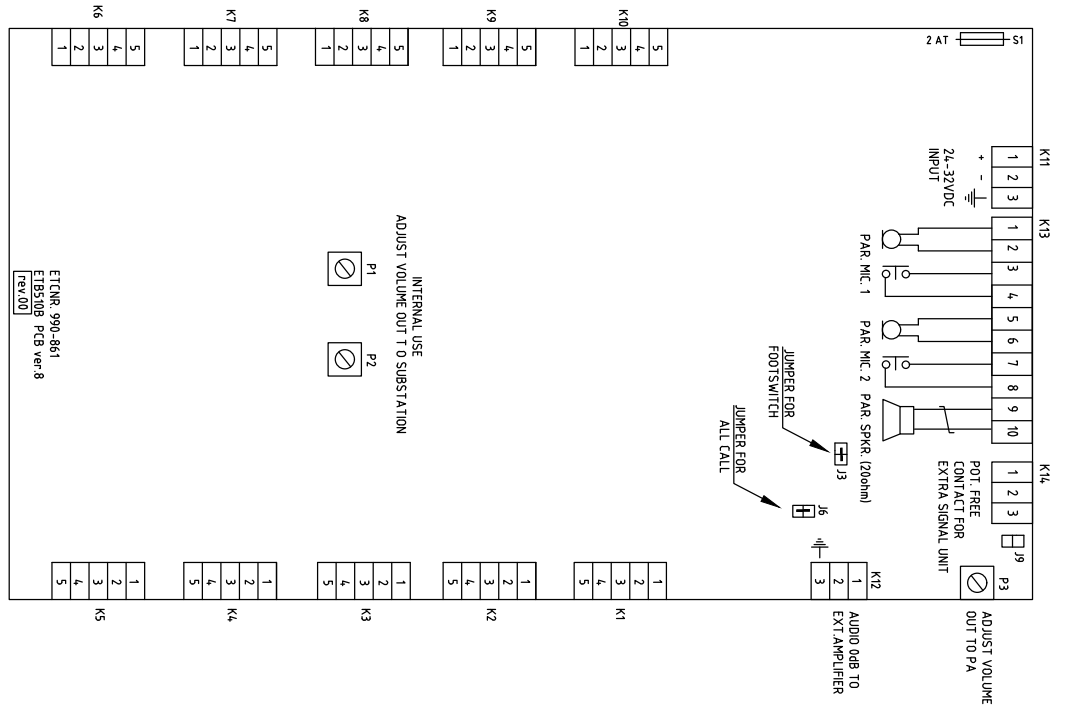

The figure shows ETB-10. ETB-5 are equipped without K6-K10. Otherwise similar.

	COMMAND TALK BACK SYSTEM			
	Type ETB-5, ETB-10 & ETB-10A Lay out terminals, jumper, fuses, vol. adjust Back ETB510B PCB ver. 8 Front ETB510F PCB ver. 8.1			
Prepared by	Date	Project no.	Revision by	
SEN	04.10.2011	xxx		
Approved by	Date	Sheet	Rev/date	
		1/2		
Dwg no. / File	ETB-510_Lay out PCB ver. 8			Rev. no.
				00

ETBALL V.3.00 &
 ETB-ALL-SUB FOR
 ETB-10A ONLY

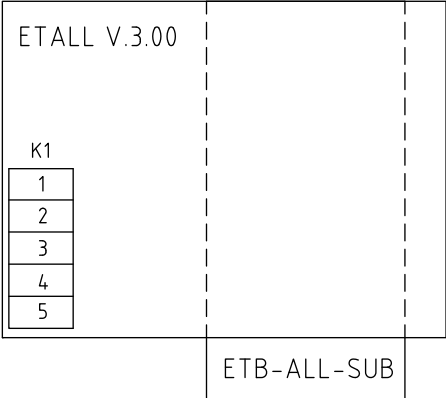

ETB510F PCB ver.8 rev.01

ETB510B PCB ver.8 ver.00

 VINGTOR	COMMAND TALK BACK SYSTEM Type ETB-5, ETB-10 & ETB-10A Lay out all PCB ETB510B PCB ver.8 ETB510F PCB ver.8.1 ETALL V3.00 / ETB-ALL-SUB		Prepared by SEN	Date 04.10.2011	Project no: 	Revision by
	Approved by 	Date 	Sheet 2/2	Rev.date 		
	Dwg.no. / File ETB-510_Lay out PCB ver.8		Rev. no. 00			

7.5 ETB-100 Block Diagram

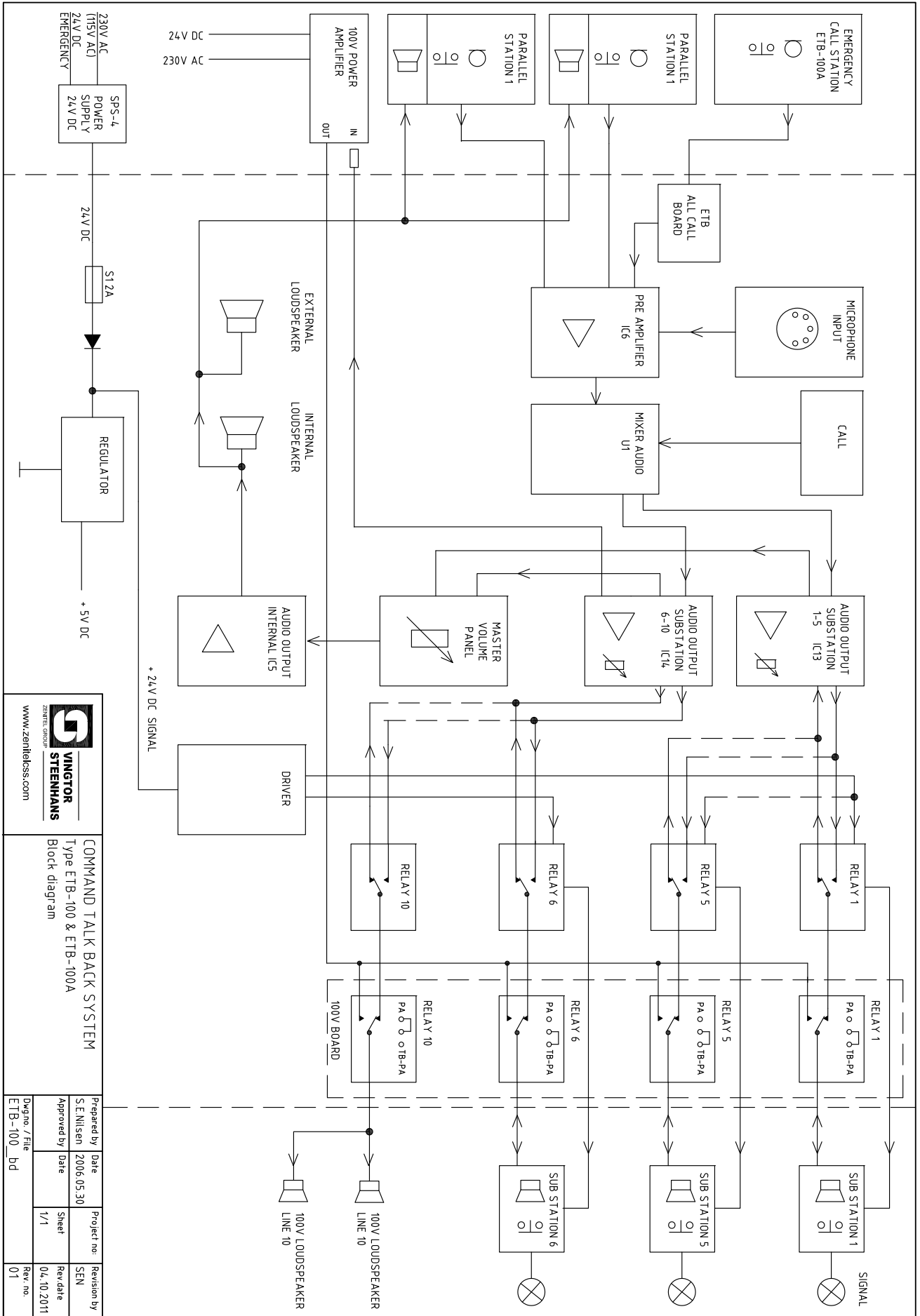

COMMAND TALK BACK SYSTEM
Type ETB-100 & ETB-100A
Block diagram

Prepared by	Date	Project no.	Revision by
S.E.NILSEN	2006.05.30	SEN	SEN
Approved by	Date	Sheet	Revdate
	1/1		04.10.2011
Dwg no. / File	Rev no.		
ETB-100_bd	01		

7.6 ETB-5/ETB-10 Block Diagram

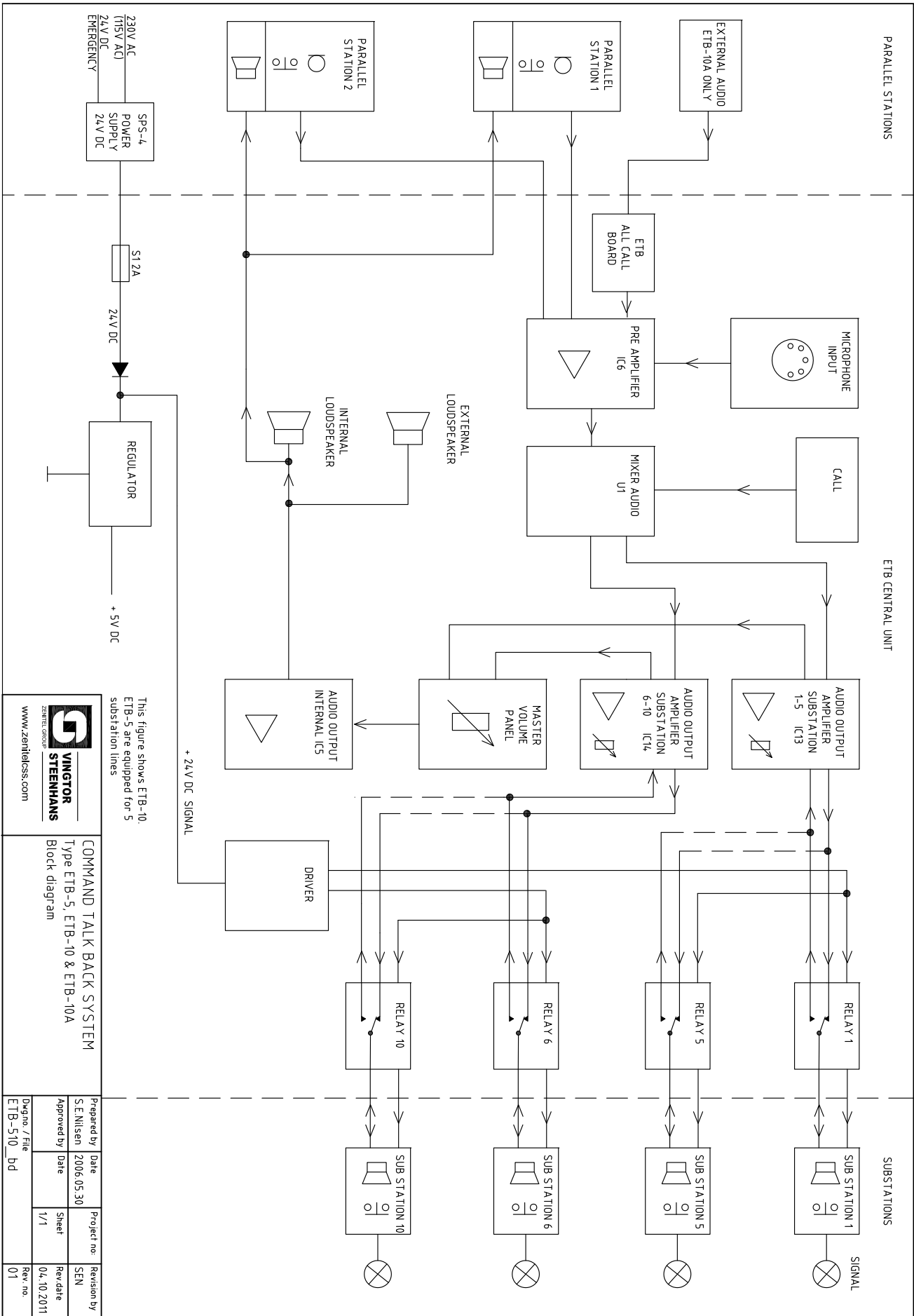

7.7 ETB-100 Cable Connection Diagrams

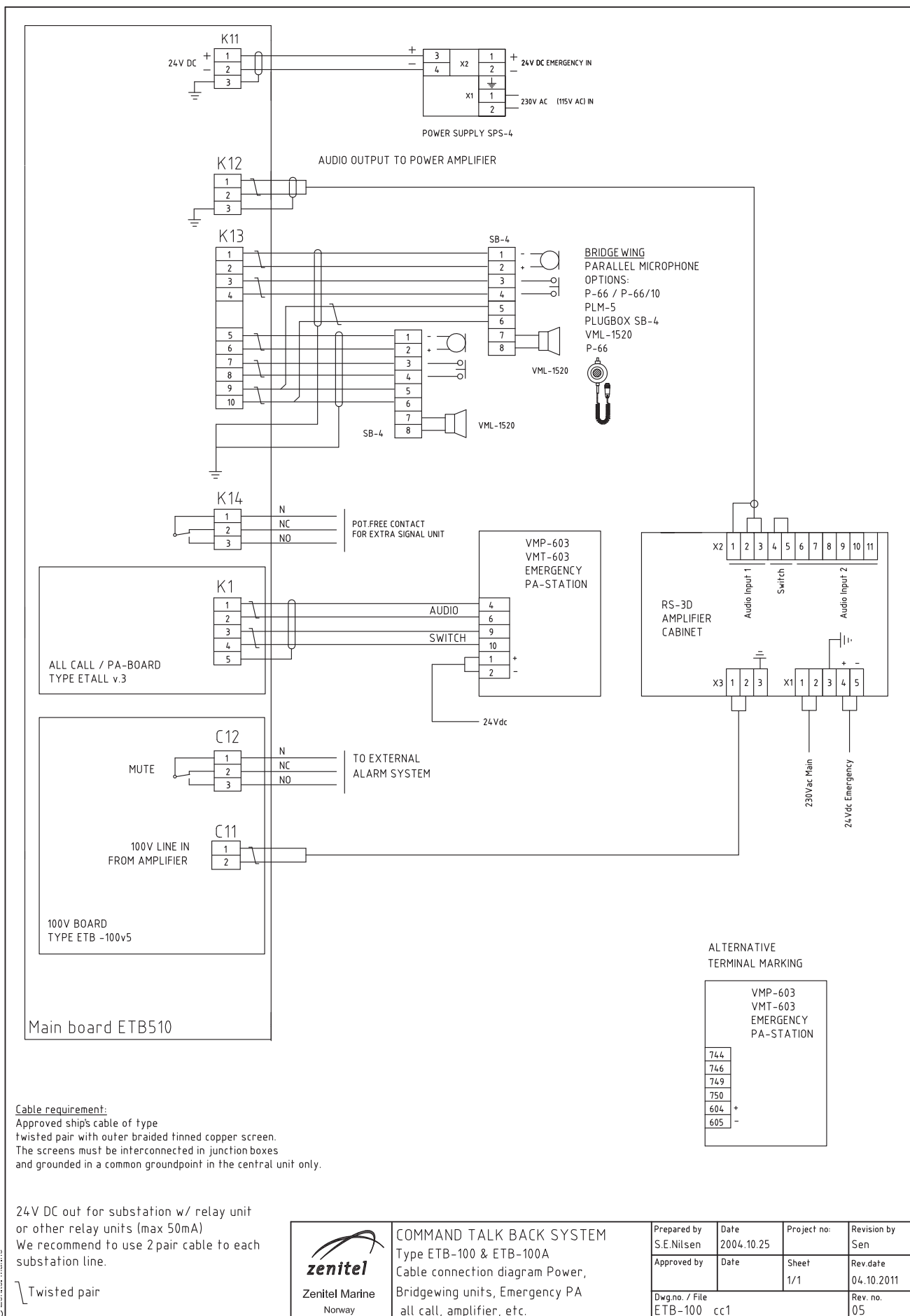

**TALK BACK CONFIGURATION
LOW IMPEDANCE**

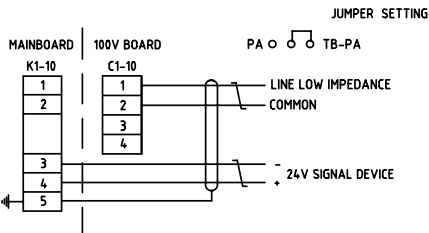

TALK BACK CONFIGURATION 100V

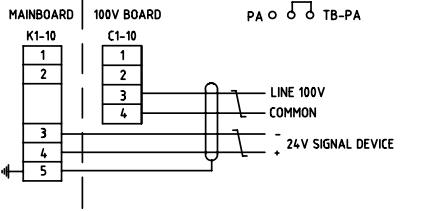

PUBLIC ADDRESS CONFIGURATION 100V

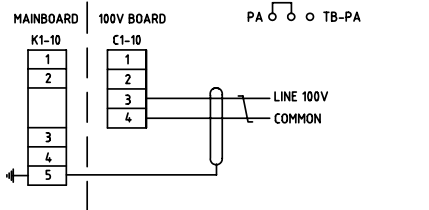



Cable requirement:

Approved shipscale of type twisted pair with outer braided tinned copper screen. The screens must be interconnected in junctionboxes and grounded in a common groundpoint in the central unit only.

Output for extra signal device for all lines. We recommend to use 2pair cable to each substation line.

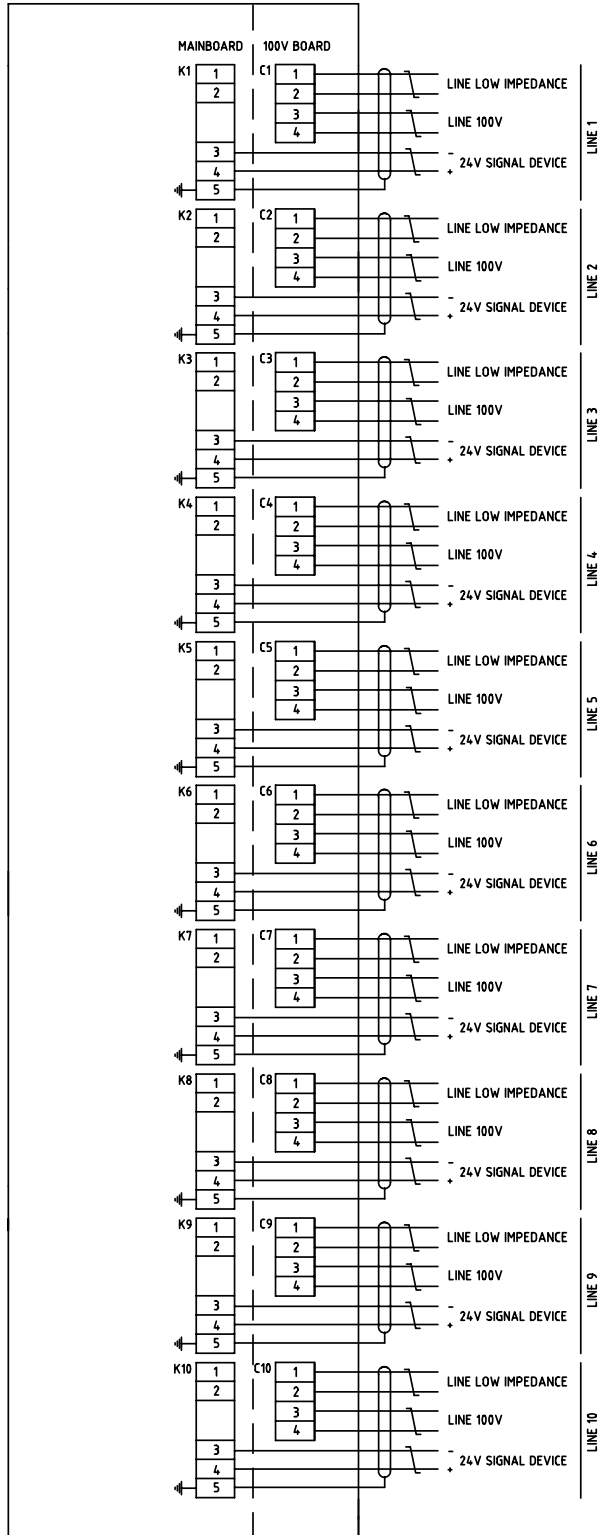
Twisted pair



 Zenitel Marine Norway	COMMAND TALK BACK SYSTEM Type ETB-100 Cable connection diagram Substations		Prepared by S.E.Nilsen	Date 2004.10.20	Project no: Sen	Revision by Sen
			Approved by	Date	Sheet 1/1	Rev.date 2005.07.11
			Dwg.no. / File ETB-100_cc2		Rev. no. 01	

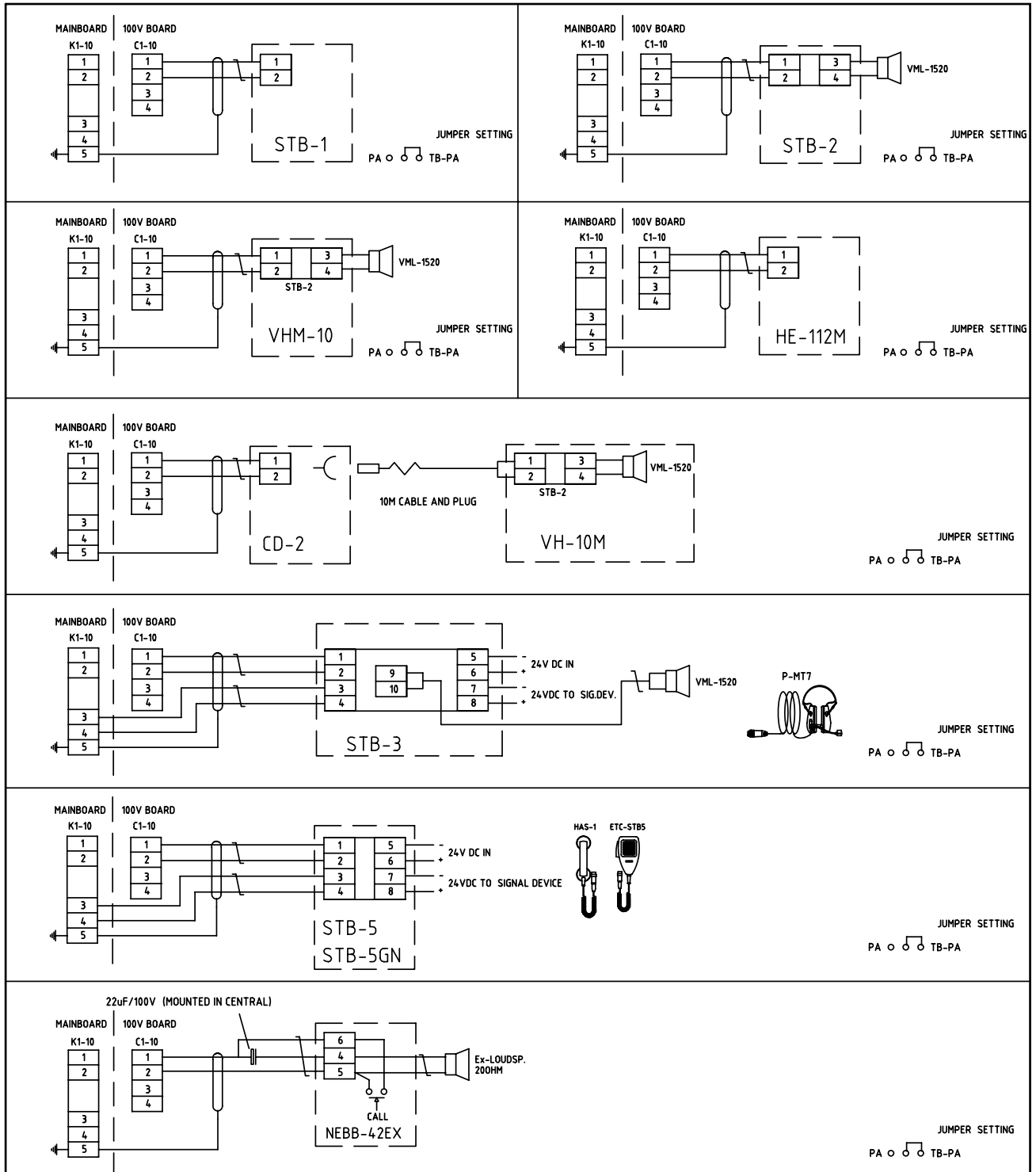

Cable requirement:
 Approved shipscale of type twisted pair with outer braided tinned copper screen. The screens must be interconnected in junctionboxes and grounded in a common groundpoint in the central unit only.

Output for extra signal device for all lines. We recommend to use 2pair cable to each substation line.

24V DC out from substation w/ relay unit to signal device max.2A

Twisted pair



COMMAND TALK BACK SYSTEM
 Type ETB-100
 Connection substations 1
 Low impedance

Prepared by S.E.Nilsen	Date 2004.10.20	Project no:	Revision by Sen
Approved by	Date	Sheet 1/1	Rev.date 2005.07.11
Dwg.no. / File ETB-100_cc3			Rev. no. 01

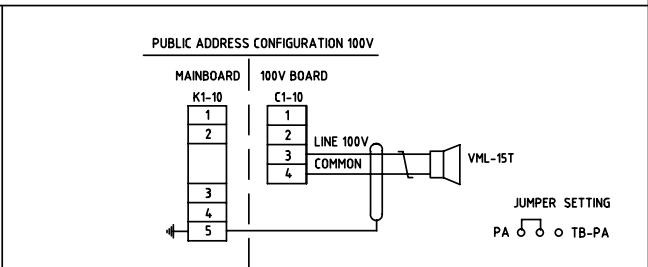
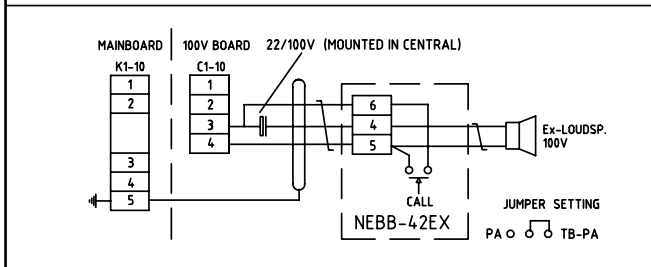
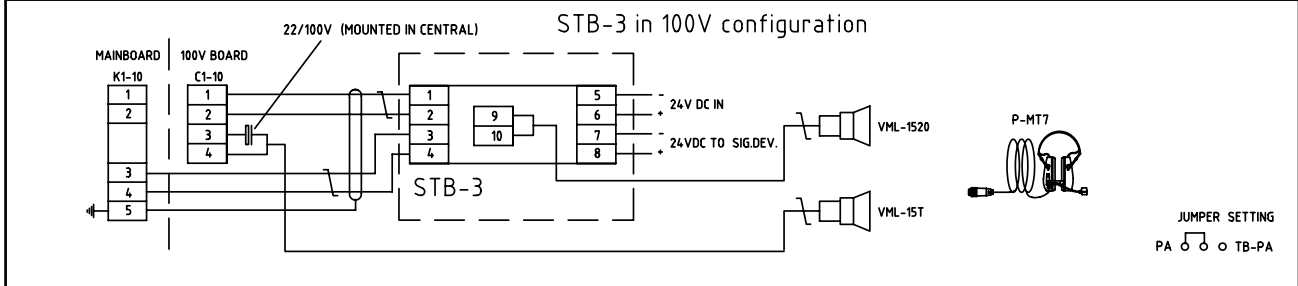
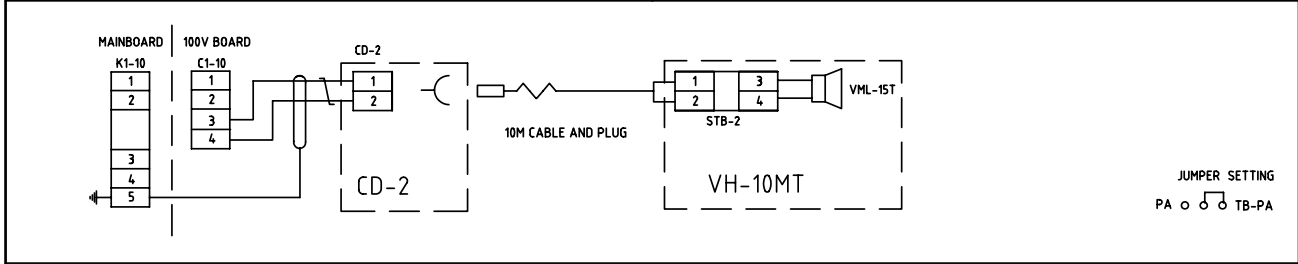
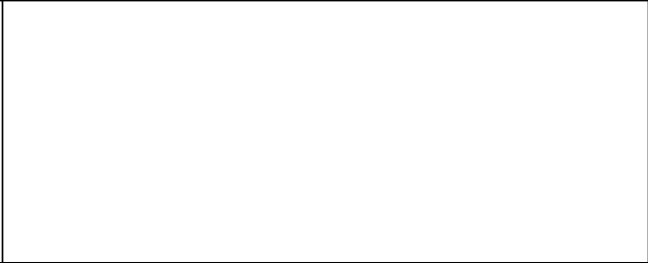
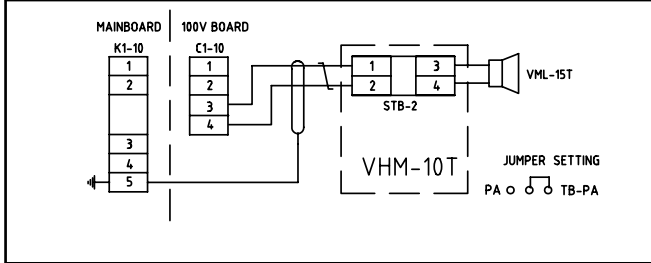
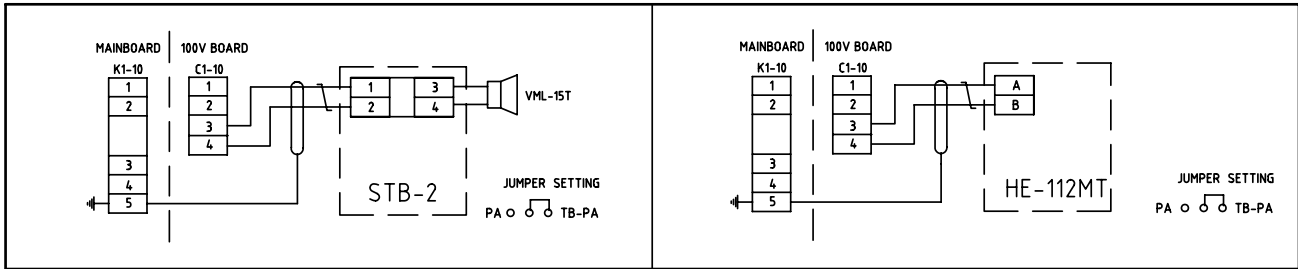

Cable requirement:

Approved shipscale of type twisted pair with outer braided tinned copper screen. The screens must be interconnected in junctionboxes and grounded in a common groundpoint in the central unit only.

Output for extra signal device for all lines. We recommend to use 2pair cable to each substation line.

24V DC out from substation w/ relay unit to signal device max.2A

Twisted pair



COMMAND TALK BACK SYSTEM
Type ETB-100
Connection substations 2
100V configuration

Prepared by S.E.Nilsen	Date 2002.09.12	Project no:	Revision by Sen
Approved by	Date	Sheet 1/1	Rev.date 2005.07.27
Dwg.no. / File ETB-100_cc4			Rev. no. 02

7.8 ETB-5/ETB-10 Cable Connection Diagrams

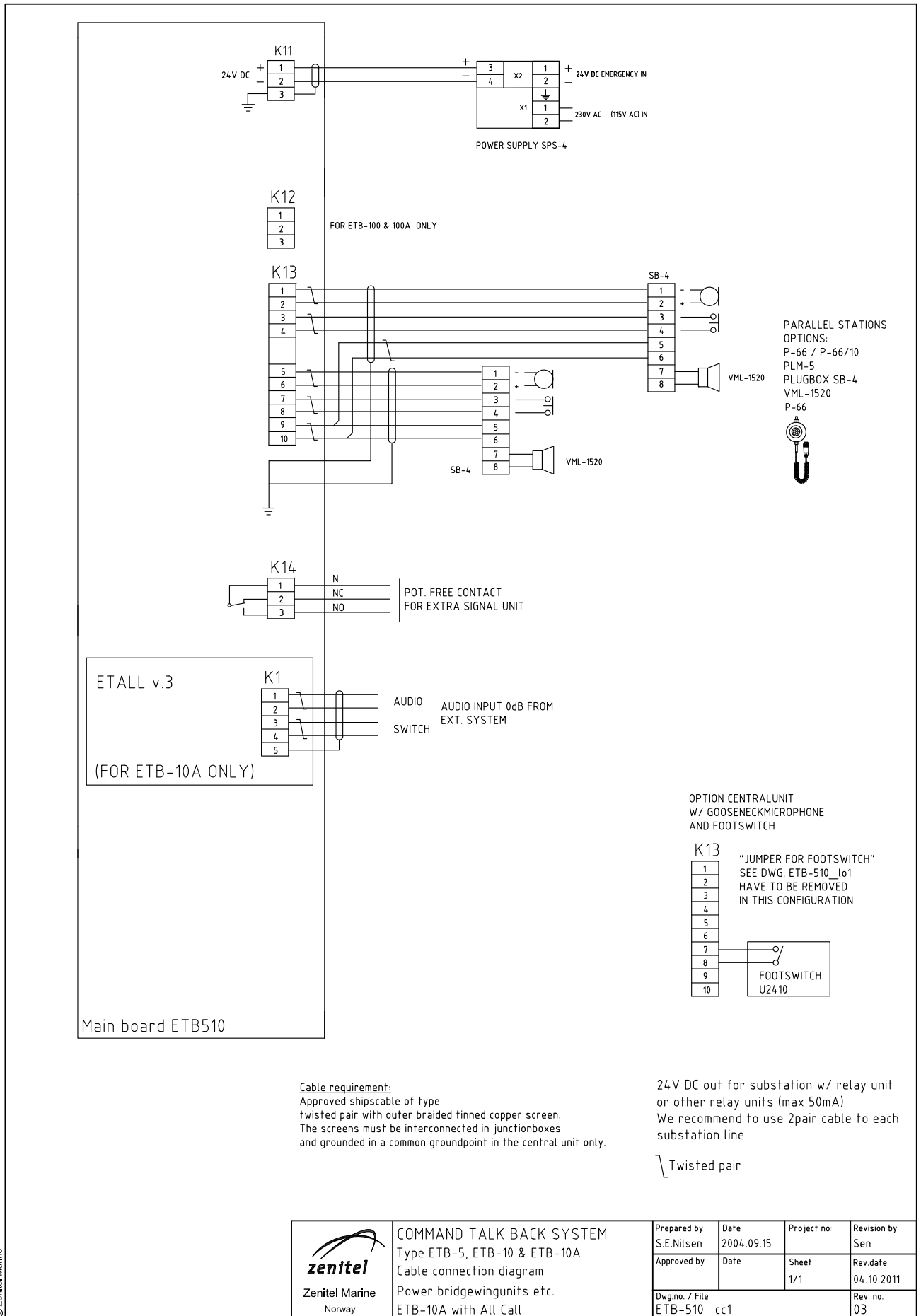

© Zenitel Marine

 Zenitel Marine Norway	COMMAND TALK BACK SYSTEM Type ETB-5, ETB-10 & ETB-10A Cable connection diagram Power bridging units etc. ETB-10A with All Call			
	Prepared by S.E.Nilsen	Date 2004.09.15	Project no:	Revision by Sen
	Approved by	Date	Sheet 1/1	Rev.date 04.10.2011
Dwg.no. / File ETB-510_cc1		Rev. no. 03		

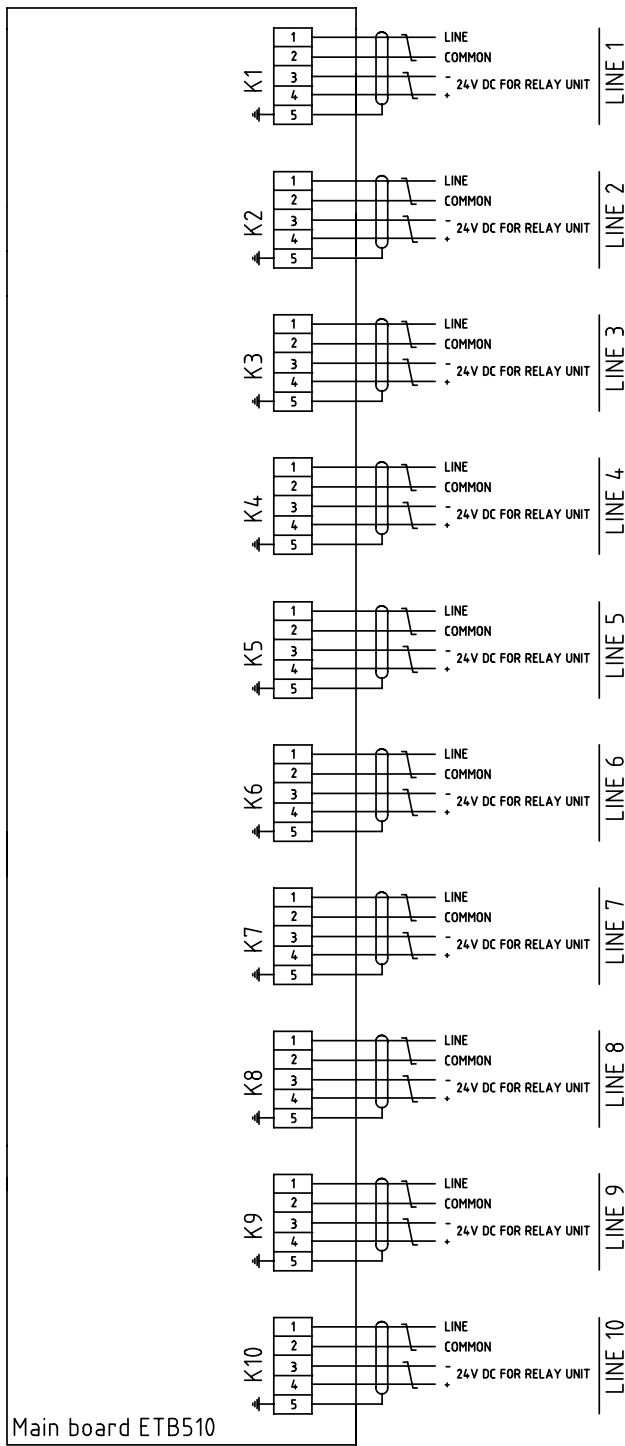

Note!

Cable requirement:

Approved shipscale of type twisted pair with outer braided tinned copper screen. The screens must be interconnected in junctionboxes and grounded in a common groundpoint in the central unit only.

Power cable 0,75mm JB is yard supply

24V DC out for substation w/ relay unit or other relay units (max 50mA)
We recommend to use 2pair cable to each substation line.

Twisted pair



COMMAND TALK BACK SYSTEM
Type ETB-5, ETB-10 & ETB-10A
Cable connection diagram substations
Line 1 - 5 ETB-5
Line 1 - 10 ETB-10

Prepared by S.E.Nilsen	Date 2004.07.23	Project no:	Revision by Sen
Approved by	Date	Sheet 1/1	Rev.date 2005.06.08
Dwg.no. / File ETB-510_cc2		Rev. no. 01	

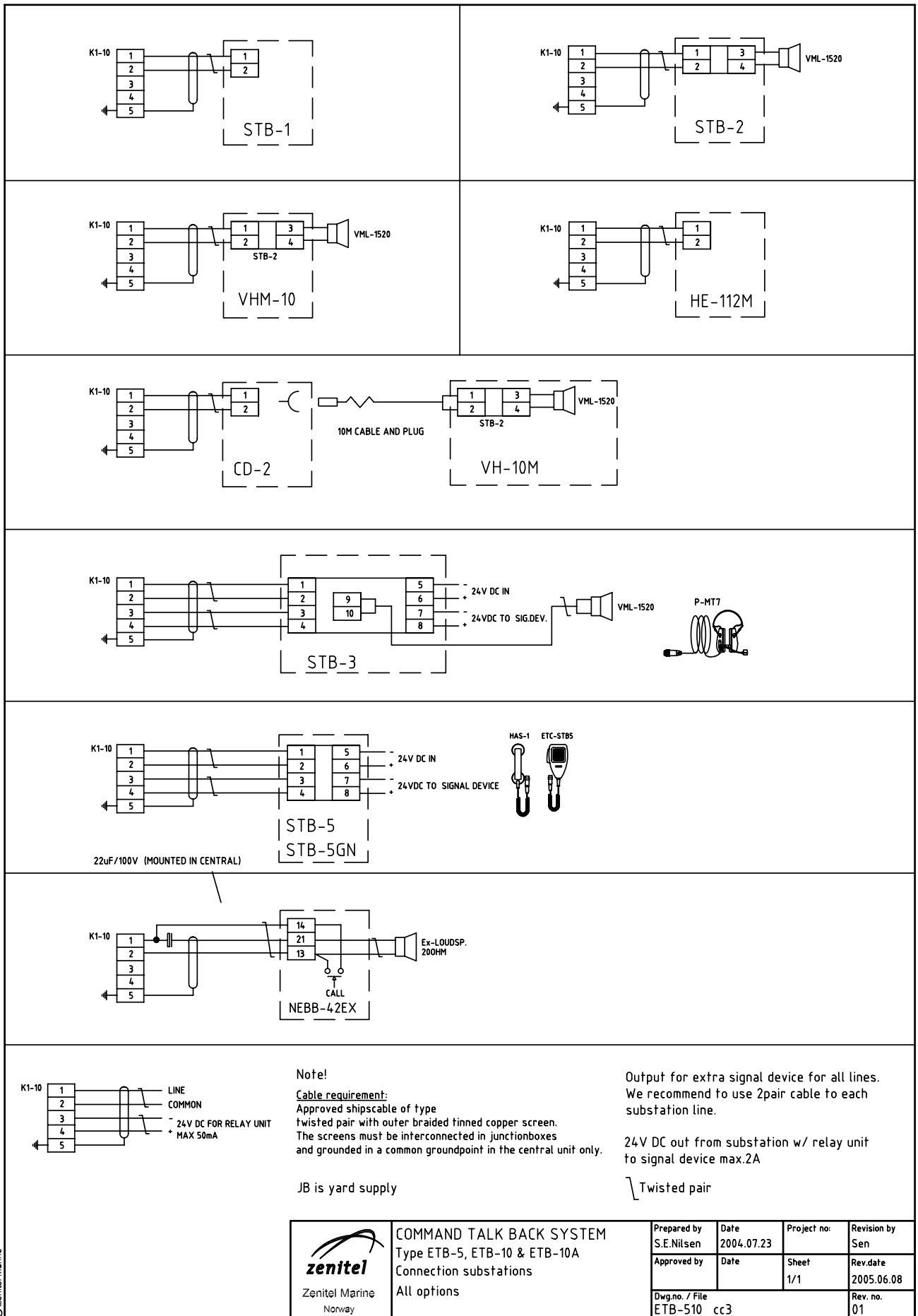

© Zenitel Marine



COMMAND TALK BACK SYSTEM
 Type ETB-5, ETB-10 & ETB-10A
 Connection substations
 All options

Prepared by S.E.Nilsen	Date 2004.07.23	Project no:	Revision by Sen
Approved by	Date	Sheet 1/1	Rev.date 2005.06.08
Dwg.no. / File ETB-510_cc3			Rev. no. 01

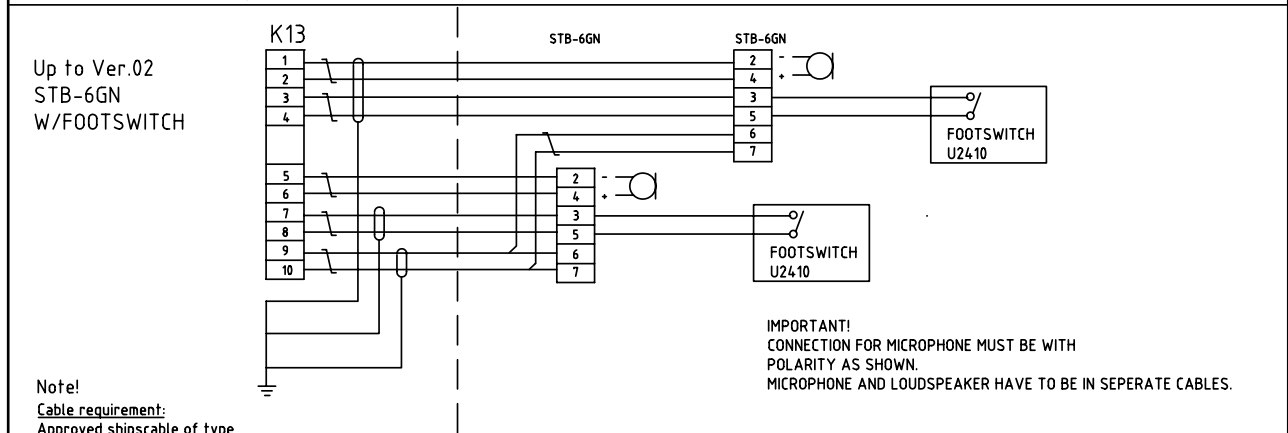
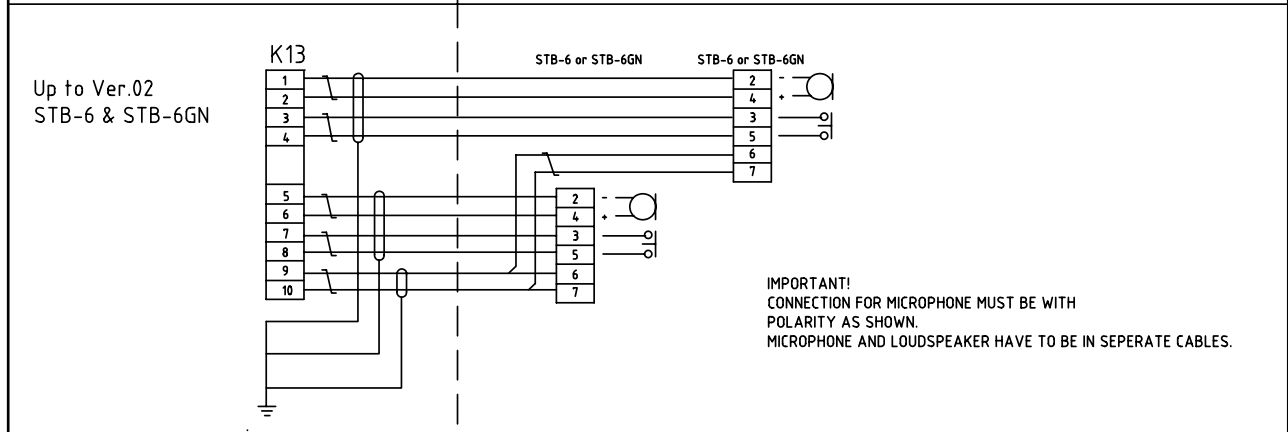
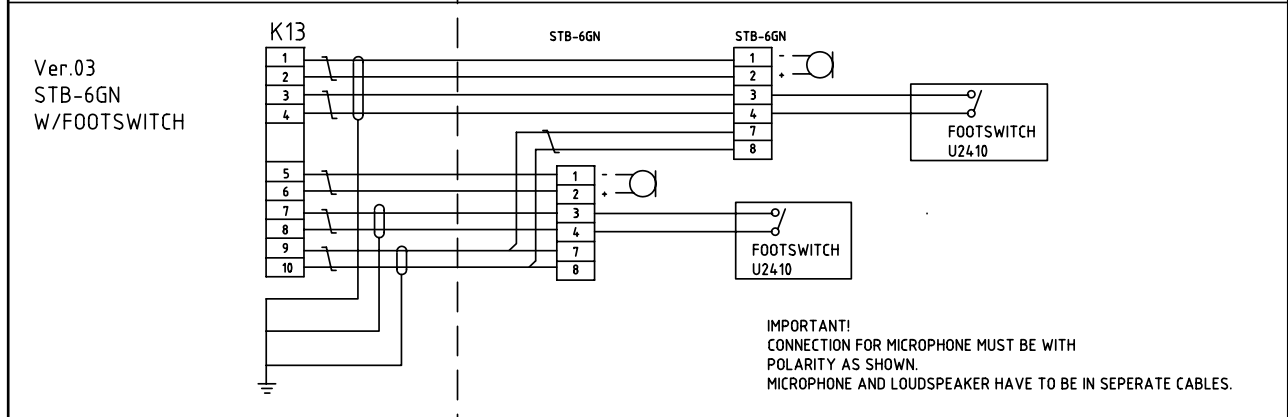
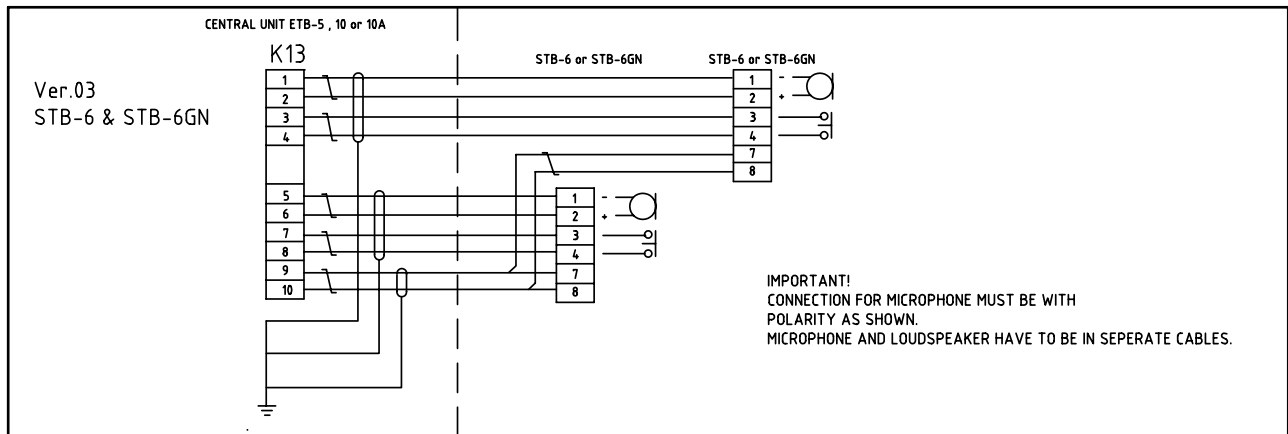

Note!

Cable requirement:

Approved shipscale of type twisted pair with outer braided tinned copper screen. The screens must be interconnected in junctionboxes and grounded in a common groundpoint in the central unit only.

Twisted pair



COMMAND TALK BACK SYSTEM
Type ETB & ETB-100
Cable connection diagram
Connection for parallel microphone
STB-6 & STB-6GN Ver.02 and 03

Prepared by S.E.Nilsen	Date 2004.10.08	Project no:	Revision by Sen
Approved by	Date	Sheet 1/1	Rev.date 2005.06.08
Dwg.no. / File ETB-STB-6_cc		Rev. no. 01	

