



Exigo Ex Access Panels
Turbine Ex Intercoms
Installation & Maintenance Procedures



 Ex schedule document.
All changes must be
approved by a Notified Body.



Contents

1	About this Document	3
1.1	Scope	3
1.2	Revision History.....	3
1.3	Certificates.....	3
2	The Ex Products	4
3	System Design Overview	5
3.1	Ex Protection Strategy.....	5
3.1.1	Marking	5
3.1.2	Specific Conditions of Use	6
3.2	Connection to Central Equipment	6
3.3	Electrical Connections	7
3.3.1	Connection of Audio Accessories.....	9
3.3.2	Earthing.....	11
3.3.3	Cable Insertion	11
3.4	Electrical Parameters	12
3.4.1	Electrical Data	12
3.4.2	Intrinsically Safe Connections for External Audio Accessories.....	12
3.4.3	Intrinsically Safe Connections for External Push Buttons.....	13
3.4.4	External Loudspeaker	13
3.4.5	Relay Output to External Signaling Device	13
3.4.6	Debug Connector.....	13
3.5	Terminals and Connectors	14
4	Maintenance Service	15
4.1	General.....	15
4.1.1	Watertight Enclosure.....	15
4.1.2	Wires.....	15
4.2	Repair / Overhaul / Modifications	15
4.3	End of Life and the WEEE directive	16

1 About this Document

1.1 Scope

This document describes the installation and maintenance procedures for the Exigo EAPFX Ex Access Panels and Turbine TFIX Ex Intercom Stations, henceforth commonly referred to as “Ex Products”, and their intended audio accessories.

The following models are covered by this manual:

Item Number	Item Name	Product Description
Exigo Ex PA Access Panels		
1023221611	EAPFX-1-V2	Exigo Ex Access Panel, 1 button, Flowire
1023221616	EAPFX-6-V2	Exigo Ex Access Panel, 6 buttons, Flowire
Turbine Ex Intercom Stations		
1008123110	TFIX-1-V2	Turbine Ex Intercom Station, Full Keypad
1008123120	TFIX-2-V2	Turbine Ex Intercom Station, 6 buttons
1008123130	TFIX-3-V2	Turbine Ex Intercom Station, 3 buttons
Ex Accessories		
AK5850HS	AK5850HS	Ex-Approved Headset with plug
1008150025	TAX-2B	Ex-Approved Plugbox & Cable for AK5850HS Headset with PTT Button
1008150030	TAX-3	Ex-Approved Handset with PTT, unterminated
1023533511	EMMAX-1H	Exigo Handheld Industrial Ex Microphone, 1 Button, IP66

1.2 Revision History

Rev.	Date	Prepared by	Comments	Approved by Ex responsible
1.0	13.1.2022	Hon Khiam Leong	V2 Turbine-Exigo, FCDC3	Erik Bjørkander

1.3 Certificates

ATEX Certificate number	DNV 21 ATEX 04699X
IECEx Certificate number	IECEX DNV 21.0097X
Certificates can be downloaded from www.zenitel.com	



2 The Ex Products

The Ex Products are approved according to IECEx and ATEX regulations, and bear the marking:
 ⚠ II 2(2)G Ex eb ib mb (ib) IIC T4 Gb (See section 3.1.1 *Marking* for detailed information).

The following models and audio accessories are approved for use in hazardous areas:

Access Panels



EAPFX-1-V2



EAPFX-6-V2

Intercoms



TFIX-1-V2



TFIX-2-V2



TFIX-3-V2

Audio Accessories



AK5058HS



TAX-2B

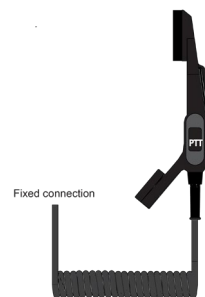

TAX-3



EMMAX-1H

3 System Design Overview

3.1 Ex Protection Strategy

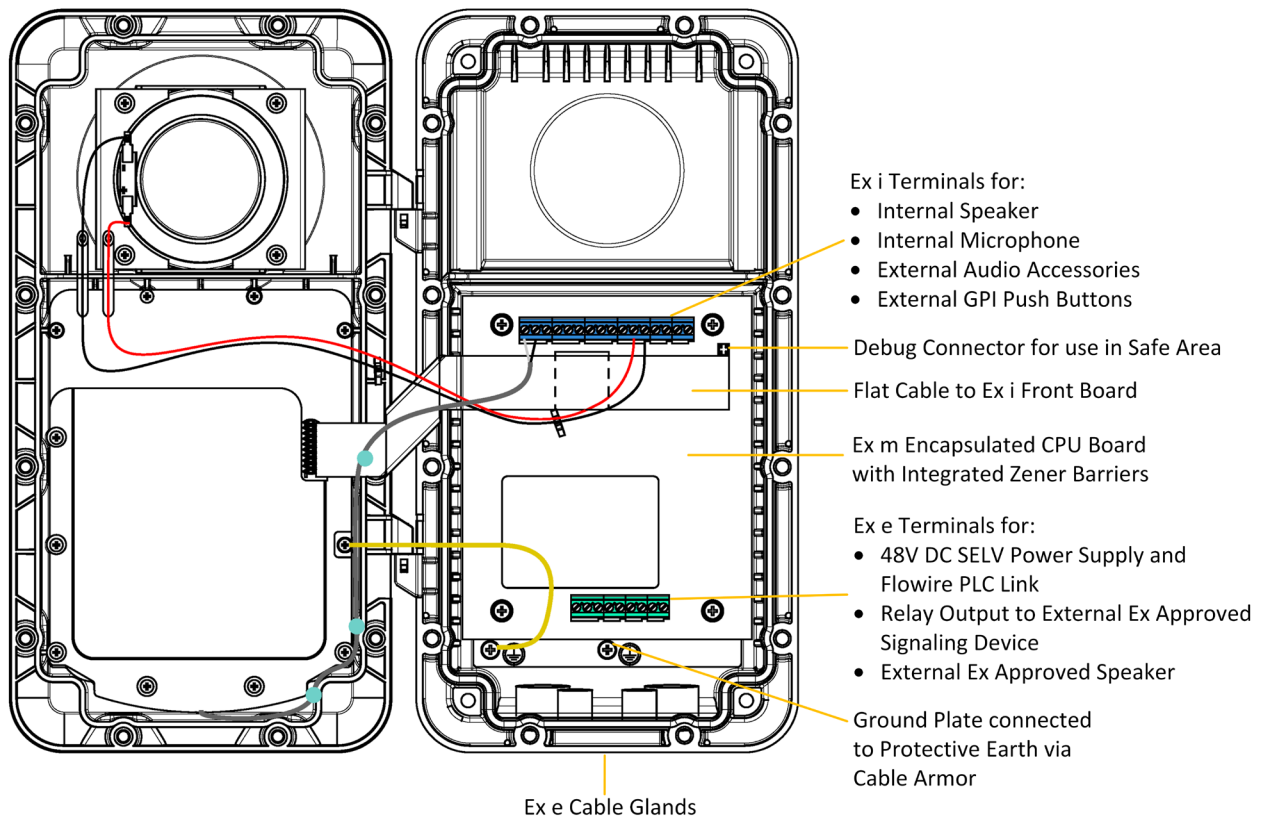

⚠ Conductors of the intrinsically safe audio accessories and GPI push buttons shall not be carried in the same cable or cable gland as conductors of the non-intrinsically safe power supply, relay and external speaker.

3.1.1 Marking

The Ex Products have the following marking:

⊕ II 2(2)G Ex eb ib mb [ib] IIC T4 Gb

zenitel		TFIX-x-V2	
Zenitel Norway AS Bromsveien 17, N3183 Horten		System: MAC: 00 13 CB XXX XX XX Flowire: MAC: 00 13 CB XX XX XX XX	
Item: XXXXXXXXXXXX.RRRR			
S/N: YYWWXXXX			
Rating: 24-48V DC SELV 2A			
Permitted supply short-circuit current: 1500A			
DNV 21 ATEX 04699X / IECEx DNV 21.0097X			
All connected accessories must conform to specifications in manual			
⊕ II 2(2)G Ex eb ib mb [ib] IIC T4 Gb Ta: -20°C to +55°C			
[] BARCODE []		2D code	
WARNING DO NOT OPEN WHEN ENERGIZED		CE 0470	

3.1.2 Specific Conditions of Use

- The Ex Products and associated cable glands are tested for low risk of mechanical hazard and shall be protected against higher impact energy levels if used.
- The cable glands shall be mounted according to the manufacturer's instructions, and additional clamping of the cable may be needed.
- Other certified cable glands than supplied with the product may be mounted and used according to the manufacturer's instructions.

3.2 Connection to Central Equipment

The Ex Products are connected to the central equipment rack using shielded 2-wire twisted pair cable. A Zenitel proprietary protocol, Flowire, is used to extend the Ethernet connection and support power distribution on the 2-wire cabling infrastructure. To support the Flowire interface, the central equipment rack must be equipped with a Flowire Converter (FCDC3).

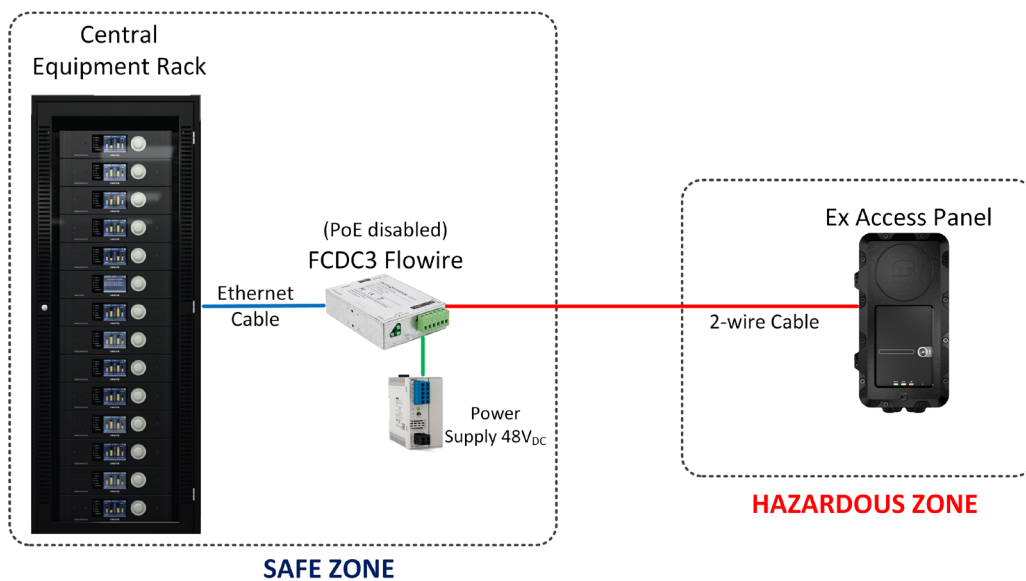

Network Configuration - Cabling in Ex Zone

3.3 Electrical Connections

All electrical connections are made on the main board inside the housing. See section 4.2 *Mounting* for instructions on opening and closing the housing

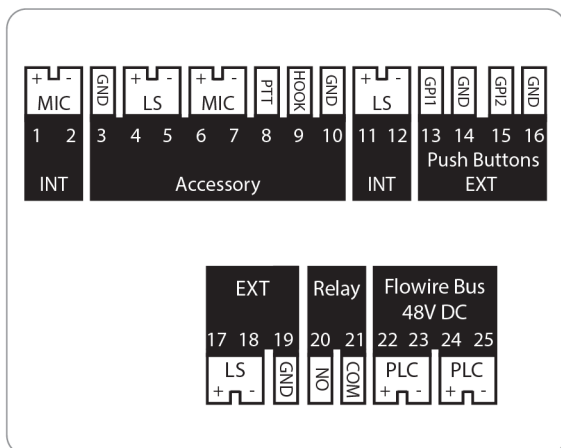
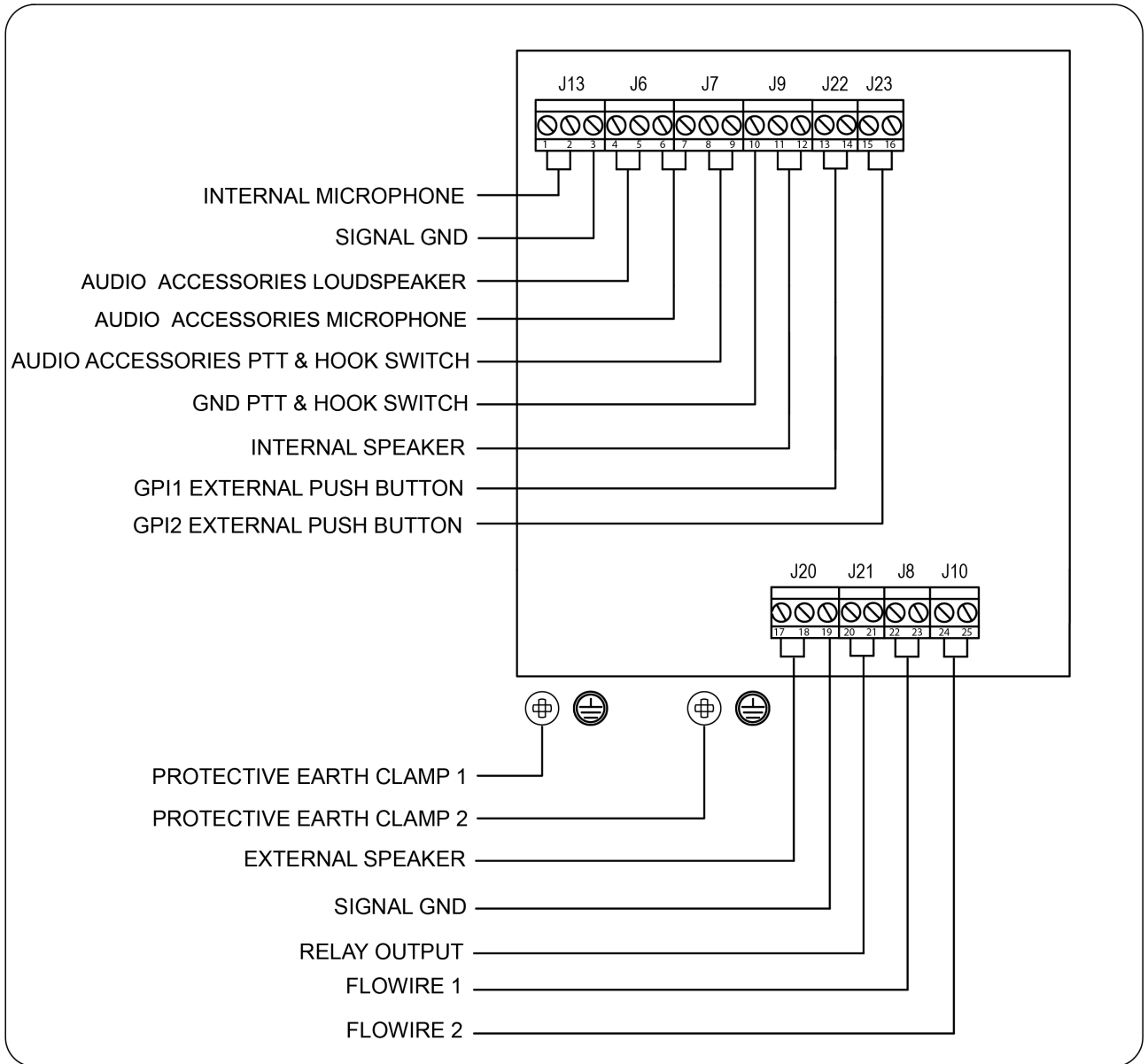

Ex i terminals:

J13	1	Internal Mic +
	2	Internal Mic -
	3	Signal GND
J6	4	Audio Accessory Speaker +
	5	Audio Accessory Speaker -
	6	Audio Accessory Microphone Mic +
J7	7	Audio Accessory Microphone Mic -
	8	Audio Accessory Push-To-Talk (PTT)
	9	Audio Accessory Hook
J9	10	Audio Accessory GND PTT/Hook
	11	Internal Loudspeaker +
	12	Internal Loudspeaker -
J22	13	GPI1 External Push Button
	14	GND External Push Button
J23	15	GPI2 External Push Button
	16	GND External Push Button

Ex e terminals:

J20	17	External Loudspeaker +
	18	External Loudspeaker -
	19	Signal GND
J21	20	Relay COM
	21	Relay NO
J8	22	Flowire PLC1 +
	23	Flowire PLC1 -
J10	24	Flowire PLC2 +
	25	Flowire PLC2 -

3.3.1 Connection of Audio Accessories

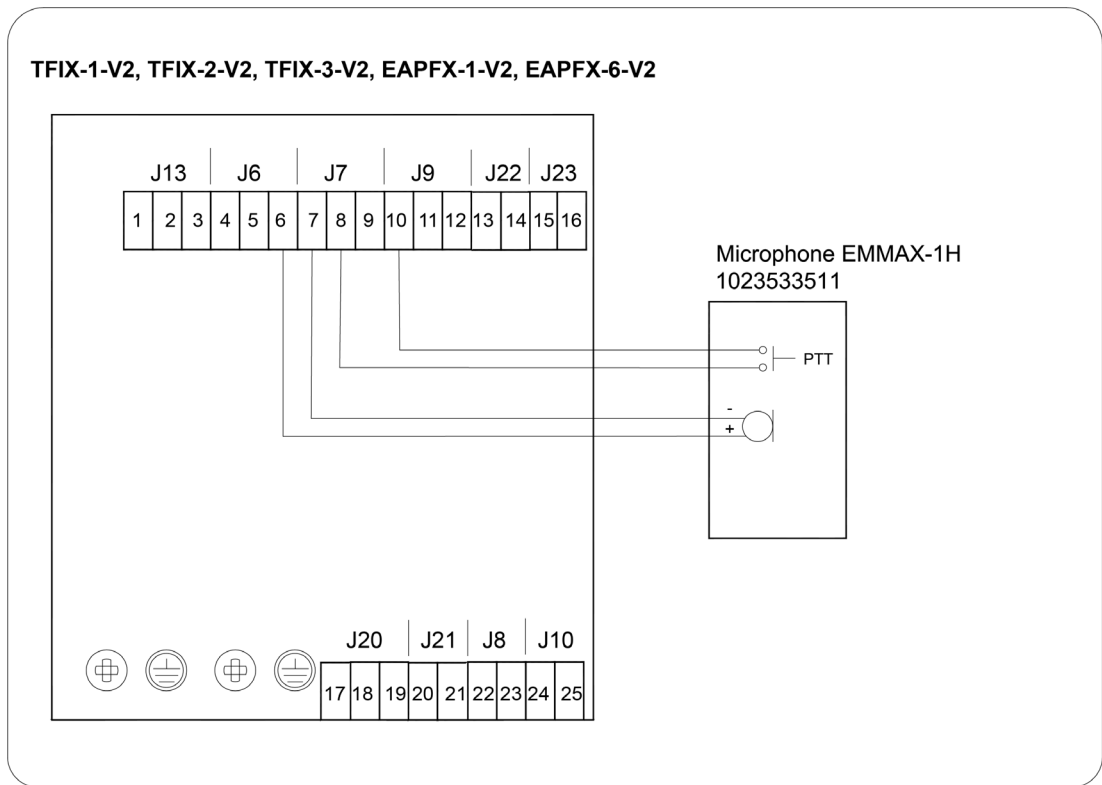

Connection of Handheld Microphone EMMAX-1H

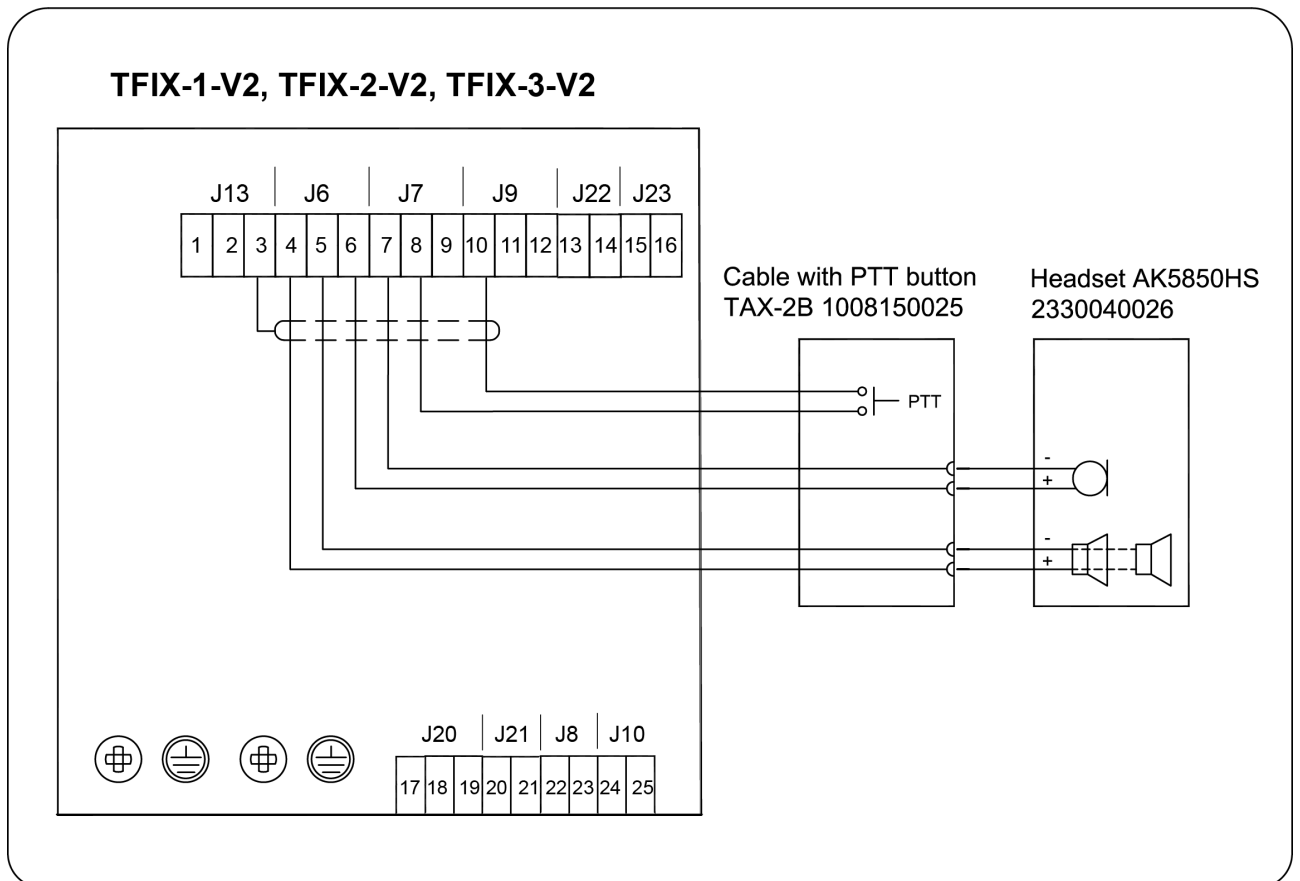

Connection of Headset AK5850HS and Plugbox TAX-2B

TFIX-1-V2, TFIX-2-V2, TFIX-3-V2

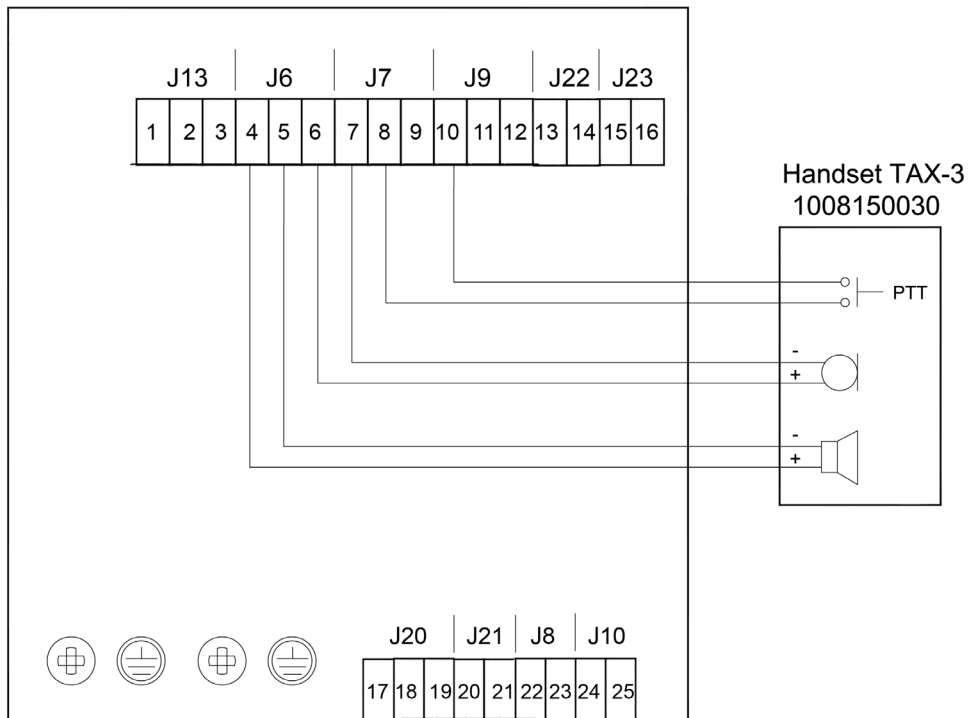

Connection of Handset TAX-3

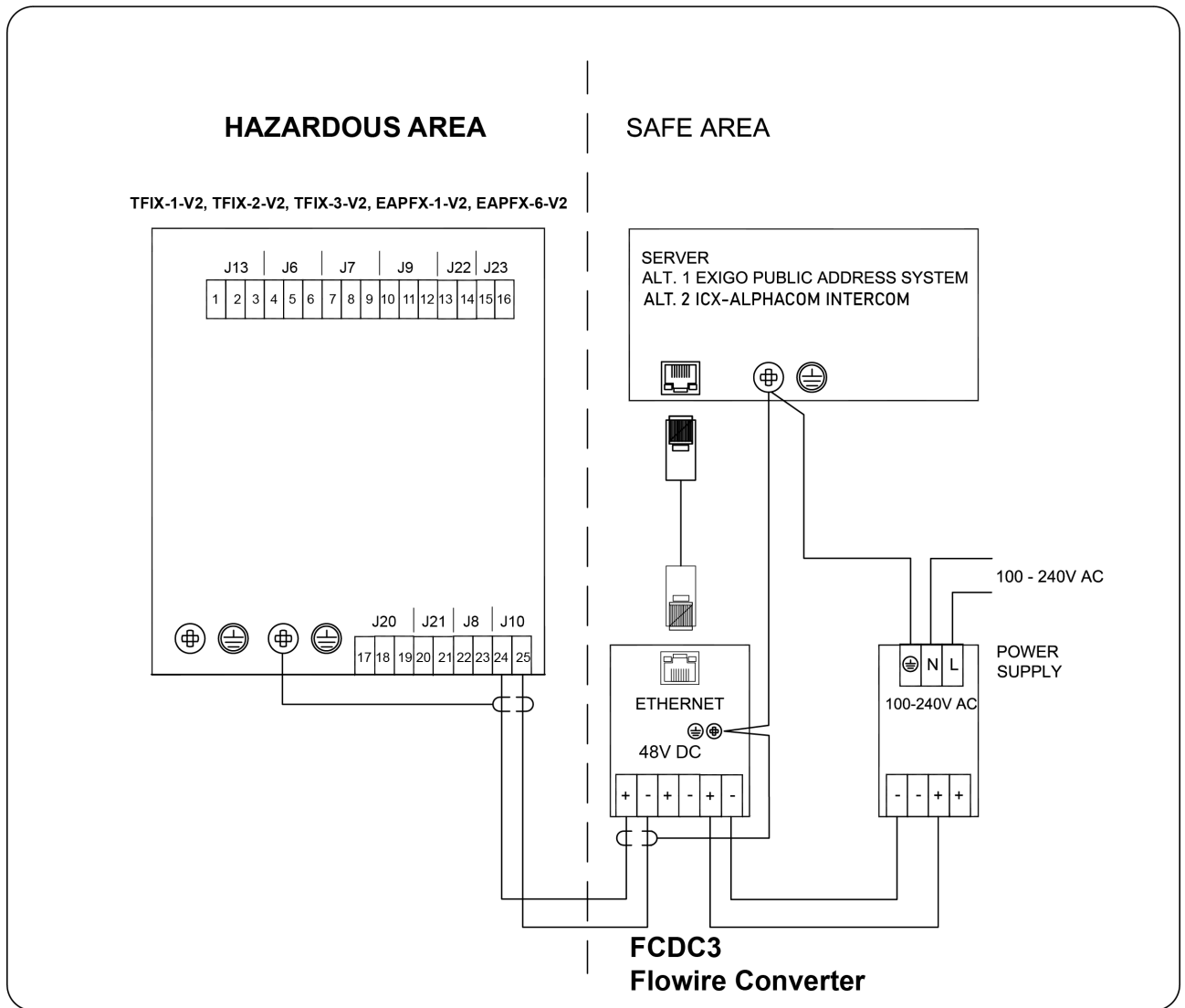

Connection of Flowire in a Single System

3.3.2 Earthing

- ⚠ The ground sheet inside the main housing must be earthed according to IEC 60079-14.

3.3.3 Cable Insertion

- ⚠ Only use cables complying with EN/IEC 60079-14.
- ⚠ Only Ex certified cable entries shall be used.
- ⚠ The relevant mounting directives for the cable entries used shall be observed.
- ⚠ Cable entries must have ingress protection IP54 or higher.

- ⚠ **When using cable entries with an ambient temperature range that differs from the ambient temperature range of the panel or intercom, the limiting temperature range shall be adhered to.**

3.4 Electrical Parameters

3.4.1 Electrical Data

Intercoms and Access Panels:

The apparatus shall be supplied with Safety Extra-Low Voltage (SELV) power supply of 24-48 VDC, 2A.

3.4.2 Intrinsically Safe Connections for External Audio Accessories

	Loudspeaker	Microphone	PTT	HOOK
Terminal	4 & 5	6 & 7	8	9
Maximum output voltage, U_o	5.8V	5.8V	5.8V	5.8V
Maximum output current, I_o	952mA	952mA	952mA	952mA
Maximum output power, P_o	1.008W	1.008W	1.008W	1.008W
Maximum external capacitance,	597nF	597nF	597nF	597nF
Maximum external inductance, L_o	40uH	40uH	40uH	40uH

The parameters above are a combination of all outputs connected together that can occur if separation distances in external accessories are below the limits in EN 60079-11:2012.

- ⚠ **Only Ex-certified audio accessories which comply with the input and output values shown in the table above may be used with the Ex Products.**
- ⚠ **Conductors of the intrinsically safe audio accessories shall not be carried in the same cable or cable gland as conductors of the non-intrinsically safe power supply, relay and external speaker.**
- ⚠ **Conductors of the intrinsically safe audio accessories shall be separated from conductors of the intrinsically safe GPI circuits by at least 0.5 mm through solid insulation.**

The following Zenitel accessories comply with the input and output values stipulated above, and are approved for use with the Ex Products:

Ex audio accessories		
2330040026	AK5850HS	Ex-Approved Headset with plug
1008150025	TAX-2B	Ex Approved Cable for Headset with PTT Button
1008150030	TAX-3	Ex-Approved Handset with PTT, unterminated
1023533511	EMMAX-1H	Exigo Handheld Industrial Ex Microphone, 1 Button, IP66

3.4.3 Intrinsically Safe Connections for External Push Buttons

	GPI1	GPI2
Terminal	13	15
Maximum output voltage, U_o	4.6V	4.6V
Maximum output current, I_o	21.2mA	21.2mA
Maximum output power, P_o	24.3mW	24.3mW
Maximum external capacitance, C_o	50uF	50uF
Maximum external inductance, L_o	100mH	100mH

The parameters above are a combination of all outputs connected together that can occur if separation distances in external accessories are below the limits in EN 60079-11:2012.

- ⚠ **Only Ex-certified accessories that comply with the input and output values shown in the table above may be used with the Ex Products.**
- ⚠ **Conductors of the intrinsically safe GPI circuits shall not be carried in the same cable or cable gland as conductors of the non-intrinsically safe power supply, relay and external loudspeaker.**
- ⚠ **Conductors of the intrinsically safe GPI circuits shall be separated from conductors of the intrinsically safe audio accessories by at least 0.5 mm through solid insulation.**

3.4.4 External Loudspeaker

Impedance	Minimum rated power
8 Ohm	25 W
20 Ohm	10 W

- ⚠ Only Ex-certified loudspeakers which comply with the minimum power ratings listed above may be used
- ⚠ Maximum load of external loudspeaker: 25 W for maximum 30 minutes
- ⚠ Maximum average load of external loudspeaker in service: 4 W

3.4.5 Relay Output to External Signaling Device

24-48 VDC SELV, max 320mA

3.4.6 Debug Connector

Debug connector, J17, for use in safe area only.

3.5 Terminals and Connectors

Hole diameter	1.3 mm
Screw thread	M3
Tightening torque, min.	0.5 Nm
Tightening torque, max.	0.6 Nm
Conductor cross section solid, min.	0.2 mm ²
Conductor cross section solid, max.	4 mm ²
Conductor cross section stranded, min.	0.2 mm ²
Conductor cross section stranded, max.	2.5 mm ²
Conductor cross section stranded, with ferrule without plastic sleeve, min.	0.25 mm ²
Conductor cross section stranded, with ferrule without plastic sleeve, max.	1.5 mm ²
Conductor cross section stranded, with ferrule with plastic sleeve, min.	0.25 mm ²
Conductor cross section stranded, with ferrule with plastic sleeve, max.	2.5 mm ²
Conductor cross section AWG/kcmil, min.	24
Conductor cross section AWG/kcmil, max.	12
2 conductors with same cross section, solid, min.	0.2 mm ²
2 conductors with same cross section, solid, max.	1.5 mm ²
2 conductors with same cross section, stranded, min.	0.2 mm ²
2 conductors with same cross section, stranded, max.	1.5 mm ²
2 conductors with same cross section, stranded, ferrules without plastic sleeve, min.	0.25 mm ²
2 conductors with same cross section, stranded, ferrules without plastic sleeve, max.	0.75 mm ²
2 conductors with same cross section, stranded, TWIN ferrules with plastic sleeve, min.	0.5 mm ²
2 conductors with same cross section, stranded, TWIN ferrules with plastic sleeve, max.	1.5 mm ²

4 Maintenance Service

4.1 General

The valid national regulations for the servicing/maintenance of electrical apparatus for use in potentially explosive atmospheres shall be observed.

Prior to opening the enclosure, it is necessary to ensure that the voltage supply has been isolated or to take suitable protective measures.

The necessary intervals between servicing depend on the specific application and shall be stipulated by the operator according to the respective operating conditions.

During servicing, explosion protection dependent parts shall be tested to ensure their correct state, such as in the following sections.

4.1.1 Watertight Enclosure

- Visual inspection to look for cracks or damages on the enclosure.
- Visual inspection of the screw inserts for the 12 screws connecting the front frame to the on-wall box. If any of these have moved out of their original positions, the integrity of the enclosure is jeopardized.
- Inspect all seals, gaskets and cable entries for efficiency and intactness.
- If water has entered the Ex unit, contact your supplier immediately and do not apply voltage to the unit until it has been inspected and/or replaced by a specialist.

4.1.2 Wires

- Inspect termination points for loose wires.
- Inspect wire isolation and jackets for cracks and signs of ageing.

4.2 Repair / Overhaul / Modifications

- ⚠ **Only original Zenitel parts shall be used for carrying out repairs that concern explosion protection.**

In the event of damage to the enclosures, replacement of these components is mandatory. Contact Zenitel for guidance.

Reconstruction or modifications to the unit is only possible within the scope of the approvals and shall be certified afterwards.

4.3 End of Life and the WEEE directive

⚠ The WEEE Directive does not legislate that Zenitel, as a 'producer', shall collect 'end of life' WEEE.

This 'end of life' WEEE should be recycled appropriately by the owner who should use proper treatment and recycling measures. It should not be disposed to landfill.

Many electrical items that we throw away can be repaired or recycled. Recycling items helps to save our natural finite resources and also reduces the environmental and health risks associated with sending electrical goods to landfill.



Under the WEEE Regulations, all new electrical goods should now be marked with the crossed-out wheeled bin symbol shown.

Goods are marked with this symbol to show that they were produced after 13th August 2005 and should be disposed of separately from normal household waste so that they can be recycled.

DOC NO.

A100K12133



Zenitel and its subsidiaries assume no responsibility for any errors that may appear in this publication, or for damages arising from the information therein. Zenitel products are developed and marketed by Zenitel. The company's Quality Assurance System is certified to meet the requirements in NS-EN ISO 9001. Zenitel reserves the right to modify designs and alter specifications without notice. **ZENITEL PROPRIETARY.** This document and its supplementing elements contain Zenitel or third-party information which is proprietary and confidential. Any disclosure, copying, distribution or use is prohibited, if not otherwise explicitly agreed in writing with Zenitel. Any authorized reproduction, in part or in whole, must include this legend: Zenitel – All rights reserved.