

PHONTECH

by ZENITEL GROUP

USER HANDBOOK

MPA 1600



Amendment Record

09	2019.8.6	Doc no. A100K11944 / 4000017956	HKL	ASK
08	2016.09.06	Added 1605,1606 and 1643, updated IP rating	RBH	SEH
07	2015.09.30	CN00550: Update, Service and Warranty, Utilization	ASK	SEH
06	2015.03.19	Unfinished Revision	--	--
05	2014.05.02	CN00344: Release p/n 4000017956	ASK	--
Version	Issue Date	Reason for issue	Made by	Approved by

MPA 1600 Handbook contents:

	Handbook page:
Service and Warranty	5
Utilization	5
SYSTEM DESCRIPTION (03118-000-DE)	6
- CONTENTS	7
- 1. INTRODUCTION	8
- 2. GENERAL DESCRIPTION	8
2.1 MPA 1600 OPERATION UNIT	8
2.2 MPA 1601 PA CONTROL UNIT	9
2.3 MPA 1604 PA CONTROL UNIT	9
2.4 MPA 1603 GA ALARM PANEL	9
2.5 MPA 1605 GA ALARM PANEL	10
2.6 MPA 1606 GA ALARM PANEL	10
2.7 MPA 1606 GA ALARM PANEL	11
2.8 MPA 1602 PA ENTERTAINMENT UNIT	11
2.9 TERMINAL BOARD	11
2.10 AMPLIFIERS	12
2.11 LOUDSPEAKERS	12
2.12 TYPE NUMBER / SYSTEM IDENTIFICATION	12
- 3. TECHNICAL DATA	12
3.1 MPA 1600 OPERATION UNIT	12
3.2 MPA 1601 PA CONTROL UNIT	13
3.3 MPA 1604 PA CONTROL UNIT	13
3.4 MPA 1603 GA ALARM PANEL	13
3.5 MPA 1605 GA ALARM PANEL	13
3.6 MPA 1606 GA ALARM PANEL	14
3.7 MPA 1643 GA ALARM PANEL	14
3.8 AMPLIFIERS	14
3.9 CABINETS	16
- 4. PERFORMANCE	16
4.1 GENERAL ALARM	16
4.2 FEEDBACK COUNTERMEASURES	16
- 5. REDUNDANCY	17
5.1 CENTRAL EQUIPMENT	17
5.2 LOUDSPEAKER DISTRIBUTION NETWORK	17
5.3 ALARM PANEL	17
5.4 CONTROL UNIT	17
- 6. EXTERNAL INTERFACES	18
6.1 GENERAL ALARM INTERFACE TO SHIPS WHISTLE / SIREN	20
6.2 MUTE OF EXTERNAL GENERAL ALARM DURING EMERGENCY PA	20
6.3 GENERAL ALARM WARNING (FLASHING) LIGHTS	20
6.4 ENTERTAINMENT MUTE PA / GA	20
6.5 VOLUME OVERRIDE	20
6.6 POWER FAILURE	20
6.7 GENERAL WARNING	21
INSTALLATION PROCEDURE (03118-000-IS)	22
- CONTENTS	23
- 1. INTRODUCTION	24
1.1 PA CONFIGURATION, CARGO VESSELS	24
1.2 PA CONFIGURATION, PASSENGER VESSELS	24
1.3 PA CONFIGURATION, ALL VESSELS	24
1.4 TYPE NUMBER / SYSTEM CONFIGURATION	24
- 2. INSTALLATION GUIDE	24
2.1 PLANNING	24
2.1.1 General	24
2.1.2 Loudspeaker selection / SPL	28

2.1.3 Amount of loudspeakers	28
2.1.4 Cable arrangement	28
2.1.5 Zones	29
2.1.6 Amplifiers	29
2.1.7 Short circuit protection	30
2.1.8 Compass Safe Distance	30
2.2 GENERAL ALARM ADJUSTMENT	30
2.3 FEEDBACK / INTERFERENCE CANCELLATION	31
2.3.1 Local Mute	31
2.3.2 Speech Delay	31
2.4 POWER	32
2.5 GLANDS	32
2.6 FERRULING	32
2.7 MARKING	32
2.8 FASTENING	32
2.9 PRESERVATION	32
2.10 CABLE REQUIREMENTS	33
OPERATION PROCEDURE (03118-000-OP)	34
– CONTENTS	35
– 1. INTRODUCTION	36
– 2. OPERATING DESCRIPTION	36
2.1 EMERGENCY PAGING	36
Figure 2-1	37
2.2 PAGING (Normal Paging)	37
Figure 2-2	38
2.3 ALARM (General Alarm)	38
Figure 2-3	39
Figure 2-4	39
2.4 PRIORITY	39
2.5 ZONES	40
2.6 LOCAL MUTE	40
2.7 VOLUME OVERRIDE	40
2.8 ALARM PRIORITY	40
2.9 ATTENTION TONE	40
2.10 ENTERTAINMENT	41
MPA 1600 SYSTEM, block diagram (03118-100-BD)	42
MPA 1600 SYSTEM, external connection (03118-025-EC)	43
– 1 of 8: Control Units and Alarm Panel Connection – Single & Dual system “A”	43
– 2 of 8: Control Units and Alarm Panel Connection – Dual system “B”	44
– 3 of 8: Zone and Loudspeaker distribution – Single & Dual system “A”	45
– 4 of 8: Zone and Loudspeaker distribution – Dual system “B”	46
– 5 of 8: Alarm Control inputs and outputs – Single & Dual system “A”	47
– 6 of 8: Alarm Control inputs and outputs – Dual system “B”	48
– 7 of 8: Intercom and PABX interconnection – Single & Dual system “A”	49
– 8 of 8: System interconnection – Dual system “A” and “B”	50
COMMISSIONING PROCEDURE (03118-100-CO)	51
– LIST OF CONTENT	51
– 1. SCOPE	52
– 2. TERMINOLOGY	52
2.1 Abbreviations	52
– 3. REFERENCE DOCUMENTS	52
– 4. INTRODUCTION	53
– 5. BRIEF SYSTEM DESCRIPTION	53
5.1 General	53
5.2 Central equipment	53
5.3 Access & Control panels	53
– 6. TEST PLAN	54
6.1 Test philosophy	54

6.2 Scope of test	54
- 7. SPECIFIC TEST PROCEDURE	54
7.1 General checks	54
7.2 Workmanship	55
- 8. FUNCTIONAL TESTING OF UNITS	55
8.1 MPA 1600 Operation unit	55
8.2 MPA 1601 Access units	55
8.2.1 Normal Paging	55
8.2.2 EMergency Paging	55
8.2.3 Indicators	55
8.2.4 Priority by normal paging "PA"	56
8.2.5 External Control outputs	57
8.3 Zones	57
8.4 MPA 1603 Alarm Panel	57
8.4.1 Alarm setting	57
8.4.2 External Control outputs	58
8.5 Paging during alarm (General Alarm)	58
8.6 Failure / warning outputs	58
8.7 Redundancy test	58
8.8 Sound Pressure Level	58
- 9. TEST INSTRUMENTS	60
- 10. PARTICIPANTS	60
- 11. PUNCH LIST	61
MPA 1600 OPERATION UNIT, mechanical layout (03118-001-ML)	62
MPA 1601 CONTROL UNIT, Ver. 05827, mechanical layout (03118-040-ML)	63
MPA 1601 CONTROL UNIT, Ver. 05827, external connection (03118-040-EC)	64
MPA 1604 CONTROL UNIT Ver. 05827, mechanical layout (03118-038-ML):	65
MPA 1604 CONTROL UNIT Ver. 05827, external connection (03118-038-EC):	66
MPA 1603 ALARM PANEL Ver. 05827, mechanical layout (03118-041-ML):	67
MPA 1603 ALARM PANEL Ver. 05827, external connection (03118-041-EC):	68
MPA 1600 SYSTEM, 1610 CABINET, mechanical layout (03118-125-ML)	69
PA-9312/24/36/48 COMMERCIAL PA AMPLIFIER, specification	70
PA-9312/24/36/48 PUBLIC ADDRESS POWER AMPLIFIER, operation manual	73
POWER AMPLIFIER 1670, data sheet	88

SERVICE AND WARRANTY

Zenitel warrants that the product sold by Zenitel substantially conform with said products written specifications for a period of up to 24 (twenty-four) months after invoice date. Notice of claims shall be made to Zenitel within 30 (thirty) calendar days after receipt of the product. The claim must be registered either online at www.zenitel.com/customer-service/claims or on RMA form provided by Zenitel through claims@zenitel.com.

- a) Delivered batteries are generally not covered by Zenitel warranty terms.
- b) Buyer also has an option to extend the 24 (twenty-four) (24) months warranty time at a separate charge. The details for this are found in the valid pricelist, and has to be settled before delivery of the products.
- c) The product must have been properly stored, installed and used to claim under the warranty.
- d) Within the warranty period, the Buyer shall give prompt written notice, if any part of the product is proven defective in material or workmanship, online either at www.zenitel.com/customer-service/claims or on RMA form provided by Zenitel through claims@zenitel.com.
- e) Zenitel shall not be liable to Buyer or third party claims relevant to accidental or improper use, wrong installation performed by uncertified technicians, from damage to the product, or from other circumstances beyond Zenitel's control.
- f) The product shall be returned to Zenitel, subject to prior written consent from Zenitel, in the form of a RMA reference number (Return Merchandise Authorization). The product shall be returned immediately, and no later than 60 days after RMA reference number has been received. Returned products in lack of such reference, will not be accepted by Zenitel and returned to Buyer at Buyer's cost.
- g) The cost of the return shipment is to be covered by the Buyer. Zenitel will cover the cost of shipment for replacement parts.
- h) Zenitel decides whether a defective part shall be replaced, returned to factory for repair or being repaired onboard the vessel or on site.
- i) If repair/change of parts is to be done onboard the vessel or on site, Zenitel shall approve by certification the company/technician doing the labor on their behalf.
After the repair is done onboard the vessel or on site, Zenitel will, based on the repair report, decide if the mentioned repair is a warranty matter or not. If it is a warranty matter, Zenitel will cover labor time up to 4 hours, and spare parts to correct the fault. Service technician's preparation, travelling time and travelling expenses, if any, are for the account of the Buyer.
- j) If Zenitel has to deliver new parts to solve a warranty matter before the claimed product is received for inspection and acceptance, Zenitel will invoice the new part with standard order terms at shipment, and then issue a credit note when the defective part has been received by Zenitel and approved as warranty by quality department.
- k) Repair or replacement of parts in a configuration done by Zenitel during the warranty period, has no effect on the expiration of the warranty for a complete project delivery, and does not give rise to a renewal or extension of the warranty period for the configuration.

UTILIZATION:

This equipment is not to be disposed in normal waste, but be handled in accordance with applicable waste disposal regulations in the country where the equipment is used

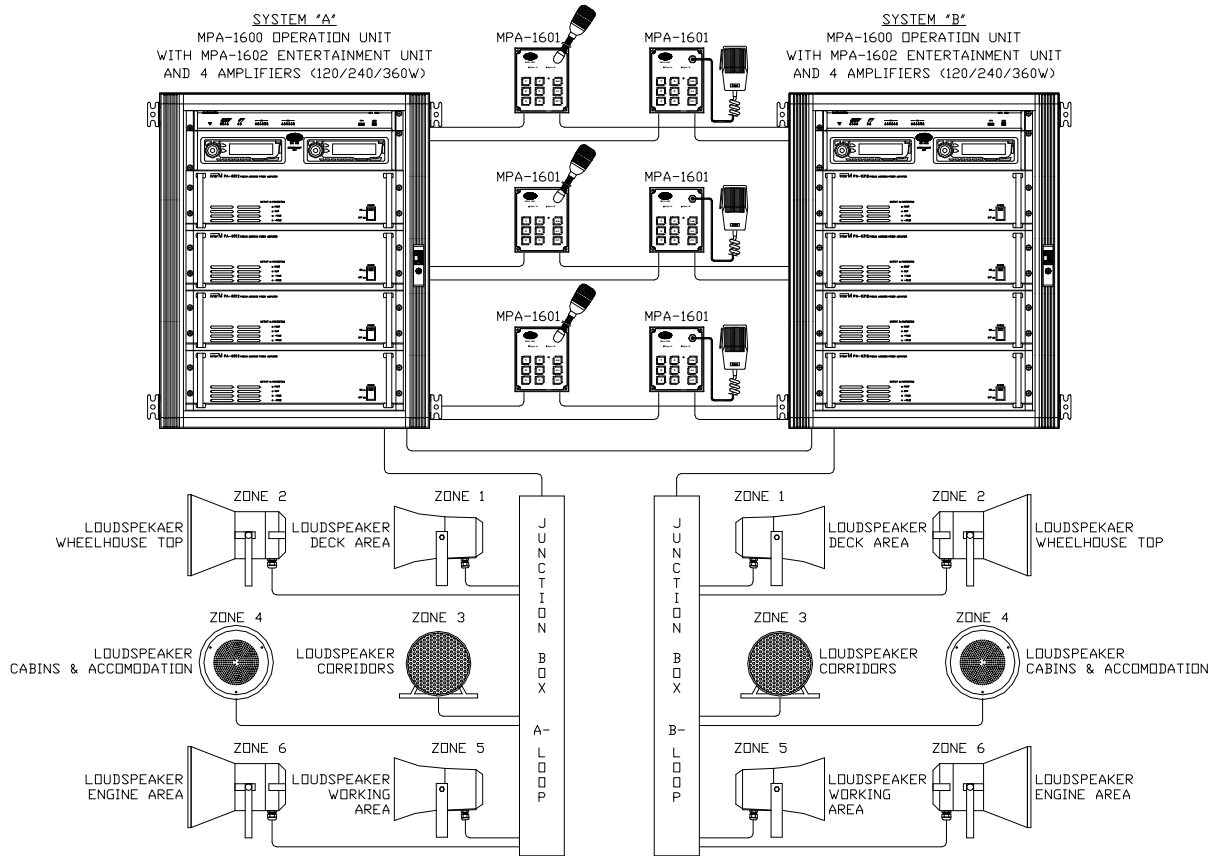

CONTENTS

CONTENTS	2
1. INTRODUCTION	3
2. GENERAL DESCRIPTION	3
2.1. MPA 1600 OPERATION UNIT	3
2.2. MPA 1601 PA CONTROL UNIT	4
2.3. MPA 1604 PA CONTROL UNIT	4
2.4. MPA 1603 GA ALARM PANEL.....	4
2.5. MPA 1605 GA ALARM PANEL.....	5
2.6. MPA 1606 GA ALARM PANEL.....	5
2.7. MPA 1643 GA ALARM PANEL.....	6
2.8. MPA 1602 PA ENTERTAINMENT UNIT	6
2.9. TERMINAL BOARD.....	6
2.10. AMPLIFIERS	7
2.11. LOUDSPEAKERS.....	7
2.12. TYPE NUMBER / SYSTEM IDENTIFICATION.....	7
3. TECHNICAL DATA	7
3.1. MPA 1600 OPERATION UNIT	7
3.2. MPA 1601 PA CONTROL UNIT	8
3.3. MPA 1604 PA CONTROL UNIT	8
3.4. MPA 1603 GA ALARM PANEL.....	8
3.5. MPA 1605 PA CONTROL UNIT	8
3.6. MPA 1606 PA CONTROL UNIT	9
3.7. MPA 1643 PA CONTROL UNIT	9
3.8. AMPLIFIERS	9
3.9. CABINETS.....	11
4. PERFORMANCE	11
4.1. GENERAL ALARM	11
4.2. FEEDBACK COUNTERMEASURES	11
5. REDUNDANCY.....	12
5.1. CENTRAL EQUIPMENT.....	12
5.2. LOUDSPEAKER DISTRIBUTION NETWORK	12
5.3. ALARM PANEL	12
5.4. CONTROL UNIT.....	12
6. EXTERNAL INTERFACES	13
6.1. GENERAL ALARM INTERFACE TO SHIPS WHISTLE / SIREN.....	15
6.2. MUTE OF EXTERNAL GENERAL ALARM DURING EMERGENCY PA.....	15
6.3. GENERAL ALARM WARNING (FLASHING) LIGHT	15
6.4. ENTERTAINMENT MUTE, PA/GA	15
6.5. VOLUME OVERRIDE.....	15
6.6. POWER FAILURE	15
6.7. GENERAL WARNING	16

1. INTRODUCTION

The MPA-system is a marine and offshore Public Address system. It meets the requirements for PA/GA, and entertainment, distribution onboard ships and mobile offshore units. The system conforms to SOLAS, IMO and IEC regulations. Based on modular design and flexible configuration, it covers a wide range of installation complexities. Ranging from, small single loop systems, to large duplicated systems.

2. GENERAL DESCRIPTION

2.1. MPA 1600 OPERATION UNIT

The MPA 1600 Operation Unit is the system central logic controller in the MPA-system. It is designed for 19" 1 Unit rack mounting.

FEATURES:

- Up to 6 zones, selectable in any configuration.
- Up to 6 MPA 1601 / 1604 /1605 / 1606 / 1643 Control Units or
- Up to 6 MPA 1603 Alarm Panels in combination with MPA 1601 panels.
- Up to 2 emergency microphones.
- External paging facility (from ICS6200/DICS6100/PABX etc.).
- Prepared for duplication - A/B dual system, with synchronisation.
- Interfaces for manual and/or automatic alarms.
- 2 entertainment sources, with free zone selection (MPA 1602)
- Signal processing capabilities.
- Configurable priority levels.
- 7 audio outputs, with unlimited amplifier expansion.
- Facility for muting of local loudspeaker during paging.
- Override of entertainment volume-controls during paging.
- Output for mute of external GA system.
- Output for activation of external GA system.
- Synchronisation with external GA tones.
- Up to 8 different alarms in the system.
- Up to 6 MPA 1603 Alarm Panels, with up to 4 different alarms.
- Chime/"ding-dong" generator.
- Alarm light signal activation.
- Mute of external alarm facility.
- Built-in loudspeaker, to monitor activity on zones.

INDICATORS

- Power status indicator with a red/green led.
- Warning/Info indication with a red/green led.
- Link/Tx indication with a green led.
- PA led indication with a green led.
- Alarm indication with a green led.
- Zone status indication with 6 red/green leds.
- MPA 1601/1603/1605/1606/1643 User status indication with 6 red/green leds.

2.2. MPA 1601 PA CONTROL UNIT

The MPA 1601 is a full facility operator control unit in the MPA system. It is designed for flush mounting.

FEATURES:

- Microphone options are Gooseneck, or Handheld.
- RS485 data communication with MPA1600 Operation Unit.
- 6 Zone-selection keys.
- PA (normal paging) key
- Emergency PA key marked with red colour
- Emergency PA key is protected against unauthorised use by means of time-trap functionality (the Emergency PA key must be held for 1 sec. before activation).
- Dimmer key
- Status-Led for system A and system B.
- Led-indicators for all keys.
- Dimmable Backlight and indication leds
- Local mute relays.

2.3. MPA 1604 PA CONTROL UNIT

The MPA 1604 is an operator control unit without Emergency PA facility in the MPA system. It is designed for flush mounting.

FEATURES:

- Microphone options are gooseneck, or handheld.
- RS485 data communication with MPA1600 Operation Unit.
- 6 Zone-selection keys.
- PA (normal paging) key.
- Status-Led for system A and system B.
- Led-indicators for all keys.
- Local mute relays.

2.4. MPA 1603 GA ALARM PANEL

The MPA 1603 is a manual alarm control unit in the MPA system. It is designed for flush mounting.

FEATURES:

- RS485 data communication with MPA1600 Operation Unit.
- 4 Alarm keys marked with the text "ALARM" and red colour
- Cancel key.
- Protection against unauthorised use by means of time-trap functionality (the alarm keys and the Cancel keys must be held for 1 sec. before activation).
- 6 leds indicating alarm status in each zone.
- Led indicators for all keys.
- Dimmable backlight and leds, remotely controlled from the adjacent MPA 1601 Control Unit.

2.5. MPA 1605 GA ALARM PANEL

The MPA 1605 is a full facility operator control unit with manual alarm controls in the MPA system. It is designed for desk-top mounting/placement.

FEATURES:

- Microphone options are Gooseneck, or Handheld.
- RS485 data communication with MPA1600 Operation Unit.
- 6 Zone-selection keys.
- 4 Alarm keys marked with the text “ALARM” and red colour
- Cancel key.
- PA (normal paging) key
- Emergency PA key marked with red colour
- Protection against unauthorised use by means of time-trap functionality (the EM/alarm keys and the Cancel keys must be held for 1 sec. before activation).
- Dimmer key
- Status-Led for system A and system B.
- Led-indicators for all keys.
- Dimmable Backlight and indication leds
- Local mute relays.

2.6. MPA 1606 GA ALARM PANEL

The MPA 1606 is a full facility operator control unit with manual alarm controls in the MPA system. It is designed for flush/19” rack mounting.

FEATURES:

- Microphone options are Gooseneck, or Handheld.
- RS485 data communication with MPA1600 Operation Unit.
- 6 Zone-selection keys.
- 4 Alarm keys marked with the text “ALARM” and red colour
- Cancel key.
- PA (normal paging) key
- Emergency PA key marked with red colour
- Protection against unauthorised use by means of time-trap functionality (the EM/alarm keys and the Cancel keys must be held for 1 sec. before activation).
- Dimmer key
- Status-Led for system A and system B.
- Led-indicators for all keys.
- Dimmable Backlight and indication leds
- Local mute relays.

2.7. MPA 1643 GA ALARM PANEL

The MPA 1643 is a full facility operator control unit with manual alarm controls in the MPA system. It is designed for wall mounting in EX areas.

The unit consists of following:

- Interface PCB for buttons.
- Interface PCB for LEDs.
- Standard PCB for 1601 User panel.
- Standard PCB for 1603 Alarm panel.
- Din rail mounted safety barriers for buttons, LEDs and audio.

FEATURES:

- Microphone options are Gooseneck, or Handheld.
- RS485 data communication with MPA1600 Operation Unit from junction box with controller boards in safe area. (Barriers in this box).
- 6 Zone-selection keys.
- 4 Alarm keys marked with the text “ALARM” and red colour.
- Cancel key.
- PA (normal paging) key.
- Emergency PA key marked with red colour.
- Protection against unauthorised use by means of time-trap functionality (the EM/alarm keys and the Cancel keys must be held for 1 sec. before activation).
- Dimmer key.
- Status-Led for system A and system B.
- Led-indicators for all keys.
- Dimmable Backlight and indication LEDs.

2.8. MPA 1602 PA ENTERTAINMENT UNIT

The MPA 1602 is a PA Entertainment Unit in the MPA system. It is designed for 19” 2 Unit rack mounting. And it is electrically isolated.

FEATURES:

- Up to 2 CD-players, or one CD-player and one external audio (TV/Video etc.)
- Configurable entertainment audio in any 6 zones per source.
- Keypad for zone selection and status indication.
- Entertainment / volume override during PA messages.

2.9. TERMINAL BOARD

Because of the high number of interfaces in the MPA system, a terminal board is necessary to interface the MPA 1600 with ship-cables. See the attached drawing 03118-025-EC and 03118-000-IS for connection and installation details.

2.10. AMPLIFIERS

The MPA system is designed to be used with a number of audio amplifiers. The amplifiers can be PA6312 (120W), PA6324 (240W), PA6336 (360W) or PA6348 (480W).

FEATURES:

- Thermal and overload protection, balanced input.
- Dual power input (AC primary / DC backup).
- (Gain adjustment 0 – [-12] service mode).

2.11. LOUDSPEAKERS

A PA/GA system like the MPA 1600 will utilize a wide variety of loudspeakers in the distribution network. Subjects like environment, topology and sound pressure requirement will determine what kind of loudspeaker type and size should be used in the specific areas.

To comply with the environment requirement all loudspeakers used in a PA/GA system must be approved according to relevant parts of IEC60945 or similar.

The topology and sound pressure requirement will be decisive for the amount of loudspeakers in the different areas, the loudspeaker type, their power rating and tapping.

See document 03118-000-IS for detailed loudspeaker selection information.

2.12. TYPE NUMBER / SYSTEM IDENTIFICATION

In order to recognise and identify different version of an MPA1600 system there is an identification system marked on all cabinets.

This system is built up as a combination of rack type and amount and type of amplifiers.

3. TECHNICAL DATA

3.1. MPA 1600 OPERATION UNIT

- 19" 1 Unit rack mounting unit.
- Operating voltage: Dual 24VDC – primary (AC through integrated Power supply module) / backup
- Current drain maximum: 5A
- Microphone input level: 5mV.
- External PA input level: 0 dBu typical (configurable)
- External entertainment input level: 0 dBu typical (configurable)
- Audio outputs to amplifiers: 0 dBu typical (configurable)
- Size: 44 x 483 x 206mm (HxWxD)
- Weight: 3kg
- Ingress Protection (stand-alone) (IP): 20
- Compass safe distance: Ref Cabinet data

3.2. MPA 1601 PA CONTROL UNIT

- Outer dimensions: 144 x 144mm.
- Operating voltage: 24VDC supplied from the MPA1600 Operation Unit.
- Current drain maximum: 300mA. (integrated in the MPA 1600)
- Microphone input level: 10mV typical (dynamic mic.)
- Ingress Protection (IP): 22
- Compass safe distance (standard): 80cm
- Compass safe distance (steering): 50cm

3.3. MPA 1604 PA CONTROL UNIT

- Outer dimensions: 144 x 144mm.
- Operating voltage: 24VDC supplied from the MPA1600 Operation Unit.
- Current drain maximum: 300mA. (integrated in the MPA 1600)
- Microphone input level: 10mV typical (dynamic mic.)
- Ingress Protection (IP): 22
- Compass safe distance (standard)¹: 80cm
- Compass safe distance (steering): 50cm

3.4. MPA 1603 GA ALARM PANEL

- Outer dimensions: 144 x 96mm.
- Operating voltage: 24VDC supplied from the MPA1600 Operation Unit.
- Current drain maximum: 100mA.
- Ingress Protection (IP): 22
- Compass safe distance (standard): 60cm
- Compass safe distance (steering): 40cm

3.5. MPA 1605 PA CONTROL UNIT

- Outer dimensions: 394 x 196 x 57,35 mm.
- Operating voltage: 24VDC supplied from the MPA1600 Operation Unit.
- Current drain maximum: 300mA. (integrated in the MPA 1600)
- Microphone input level: 10mV typical (dynamic mic.)
- Ingress Protection (IP): 22
- Compass safe distance (standard): 80cm
- Compass safe distance (steering): 50cm

¹ (The unit is physically identical to MPA 1601)

3.6. MPA 1606 PA CONTROL UNIT

- Outer dimensions: 483 x 177 x 55 mm.
- Operating voltage: 24VDC supplied from the MPA1600 Operation Unit.
- Current drain maximum: 300mA. (integrated in the MPA 1600)
- Microphone input level: 10mV typical (dynamic mic.)
- Ingress Protection (IP): 22
- Compass safe distance (standard): 80cm
- Compass safe distance (steering): 50cm
-

3.7. MPA 1643 PA CONTROL UNIT

- Outer dimensions: 160 x 360 mm.
- Operating voltage: 24VDC supplied from the MPA1600 Operation Unit.
- Current drain maximum: 300mA. (integrated in the MPA 1600)
- Microphone input level: 10mV typical (dynamic mic.)
- Ingress Protection (IP): 44
- Compass safe distance (standard): 80cm
- Compass safe distance (steering): 50cm

3.8. AMPLIFIERS

Model: PA-6336

ELECTRICAL

Power output (THD 1%)	360W (RMS)
Max load:	4 ohm (38V) 8 ohm (50V) 13,6 ohm (70V) 27,8 ohm(100V)
Frequency Response (+1/-3dB)	70Hz to 20KHz
THD at 1 KHz, Rated Output	Less than 1%
HPF	-3dB at 400Hz
Signal to Noise Ratio	Better than 95dB
Input Sensitivity/Impedance	1V/10K ohm Balanced
Input Level Adjustment (service mode)	-12dB to 0dB

GENERAL

Power source (primary)	AC 230V (220/240) 50Hz/60Hzor
(primary alternative)	AC 115V (110/120)
(backup)	DC 24V
Dimensions	W:482 x H:132 x D:280 mm
Weight	21Kg.
Compass safe distance:	Ref Cabinet data

Model: PA-6324

ELECTRICAL

Power output (THD 1%)	240W (RMS)
Max load:	4 ohm (31V) 21 ohm (70V) 42 ohm(100V)
Frequency Response (+1/-3dB)	70Hz to 20KHz
THD at 1 KHz, Rated Output	Less than 1%
HPF	-3dB at 400Hz
Signal to Noise Ratio	Better than 95dB
Input Sensitivity/Impedance	1V/10K ohm Balanced
Input Level Adjustment (service mode)	-12dB to 0dB

GENERAL

Power source (primary)	AC 230V (220/240) 50Hz/60Hzor
(primary alternative)	AC 115V (110/120)
(backup)	DC 24V
Dimensions	W:482 x H:132 x D:280 mm
Weight	19Kg.
Compass safe distance:	Ref Cabinet data

Model: PA-6312

ELECTRICAL

Power output (THD 1%)	120W (RMS)
Max load:	4 ohm (25V) 42 ohm (70V) 83 ohm(100V)
Frequency Response (+1/-3dB)	70Hz to 20KHz
THD at 1 KHz, Rated Output	Less than 1%
HPF	-3dB at 400Hz
Signal to Noise Ratio	Better than 95dB
Input Sensitivity/Impedance	1V/10K ohm Balanced
Input Level Adjustment (service mode)	-12dB to 0dB

GENERAL

Power source (primary)	AC 230V (220/240) 50Hz/60Hzor
(primary alternative)	AC 115V (110/120)
(backup)	DC 24V
Dimensions	W:482 x H:132 x D:280 mm
Weight	14Kg.
Compass safe distance:	Ref Cabinet data

3.9. CABINETS

Wall cabinet:

Type:	Rittal EL – 15U Wall Cabinet
Dimensions	W:600 x H:746 x D:615 mm
Weight	110 – 150 kg (equipment dependant).
Compass safe distance (standard):	340 cm
Compass safe distance (steering):	220 cm

Vibration Isolator:	4 x Vibratec A100216-092/6-II (Vertical against the wall) (Supports weight 110 – 150 kg)
---------------------	--

Rack:

Type:	Rittal TS8 – 42HE Equipment Rack
Dimensions	W:613 x H:2105 x D:830 mm
Weight	200 – 300kg (equipment dependant).
Compass safe distance (standard):	340 cm
Compass safe distance (steering):	220 cm

Vibration Isolator:	4 x Vibratec A100216-092/6-II (Horizontal against the floor) (Supports weight 200 – 300 kg)
---------------------	---

4. PERFORMANCE

4.1. GENERAL ALARM

The General Alarm tone in the MPA 1600 system consists of seven short followed by one long tone burst. Each short tone has approximately 1 sec. duration, each pause between tones approximately 1 sec. and the long tone has 7 sec. duration. The alarm signal sequence is continuously repeated. The alarm tone is basically generated of a 1000 Hz sinusoidal tone.

The General alarm tone can be adjusted by means of loading different configuration data. Frequencies between 200 and 2500 Hz can be selected along with triangular or sinusoidal curve form.

The configuration changes require a special administrative tool and are unavailable during normal operation.

4.2. FEEDBACK COUNTERMEASURES

In the MPA 1600 system there are three different countermeasures available in order to avoid audible feedback and disturbance during announcements.

- The MPA 1601 and 1604, Control Units are equipped with either a gooseneck or handheld microphone with close-talk characteristics with excellent background noise suppression capability.
- The MPA 1601 and 1604, Control Units, are equipped with relays for disconnecting loudspeakers in the close proximity when activated.
- Each audio interface can be programmed to be of a recording type. The message is temporarily recorded and is automatically played back when the announcement is terminated.

5. REDUNDANCY

In a PA/GA system as the MPA 1600 the design and the installation must be carried out in a way that the damage of one single failure shall be minimised as far as possible.

In the MPA 1600 such redundancy is achieved by the following measures:

5.1. CENTRAL EQUIPMENT

- All centralized equipment (MPA 1600, Amplifiers etc) is duplicated and physically separated in different fire zones – System A and B. Ref document. 03118-100-BD and 03118-100-EC.
- The A and B central equipment are connected together with a synchronisation link to coordinate alarm tone generation and other timing-related functionality. If this synchronisation link is somehow broken or damaged the systems will work individually.
- The MPA 1601 and 1604, Control Units and MPA 1603, Alarm Panel, are equipped with a duplicated interface for connection to both systems (A and B). The connection status is displayed in the System A / B led indicator of the MPA 1601 and 1604.

5.2. LOUDSPEAKER DISTRIBUTION NETWORK

- The loudspeaker distribution network is duplicated and routed separately in different cable ducts and as physically separated as possible.
- All public areas shall be covered equally from both loudspeaker distribution network.
- All cabins shall be supplied with PA/GA loudspeakers. Minimum requirement is that neighbouring cabins shall be supplied from different loudspeaker distribution network.

5.3. ALARM PANEL

In order to have a required redundancy and availability to the General alarm the minimum amount of MPA 1603 Alarm Panels is two (Alternatively 1605/1606/1643). One shall always be placed on the Navigation Bridge. At least one more shall be placed in another strategic place as an alternative position.

5.4. CONTROL UNIT

In order to have a required redundancy and availability to the Emergency PA, the minimum amount of MPA 1601 Control Units is two (Alternatively 1605/1606/1643). One shall always be placed on the Navigation Bridge. At least one more shall be placed in another strategic place as an alternative position and where it is deemed necessary.

6. EXTERNAL INTERFACES

The MPA 1600 PA/GA system is equipped with various control outputs for external equipment. This is intended for additional warnings and indicators. See also doc. 03118-025-EC:

Terminals	Name	Description	Input/output	Interface	Voltage	Current / Impedance
1 – 2	0V / AL1	Direct Alarm inputs	Input	Dry contact input	≈20VDC	2 mA
3 – 4	0V / AL2				≈20VDC	2 mA
5 – 6	0V / AL3				≈20VDC	2 mA
7 – 8	0V / AL4				≈20VDC	2 mA
9 – 10	0V / AL5				≈20VDC	2 mA
11 – 12	0V / AL6				≈20VDC	2 mA
13 – 14	0V / AL7				≈20VDC	2 mA
15 – 16	0V / AL8				≈20VDC	2 mA
17 – 18	+24V / AL1 ACT	Alarm status outputs	Output	Open collector source/sink	24VDC	40 mA
19 – 20	+24V / AL2 ACT				24VDC	40 mA
21 – 22	+24V / AL3 ACT				24VDC	40 mA
23 – 24	+24V / AL4 ACT				24VDC	40 mA
25 – 26	+24V / AL5 ACT				24VDC	40 mA
27 – 28	+24V / AL6 ACT				24VDC	40 mA
29 – 30	ALARM ON	Any Alarm ON status	Output	Dry contact output	--	0.3 A
31 – 32	ALARM SYNC IN	Alarm sequence input	Input	Dry contact input	≈20VDC	2 mA
33 – 34	ALARM SYNC OUT	Alarm sequence monitor output	Output	Dry contact output	--	0.3 A
35 – 36	GENERAL WARNING	Error monitoring output	Output	Dry contact output	--	0.3 A
37 – 38	POWER FAIL	Power monitoring output, Normally Closed	Output	Dry contact output	--	0.3 A
39 – 40	POWER FAIL	Power monitoring output, Normally Open	Output	Dry contact output	--	0.3 A
41 – 42	--	Not in Use	--	--	--	--
43 – 44	TALK USED	Any PTT is active output	Output	Dry contact output	--	0.3 A
45 – 46	EXT. PA OUT (AUDIO)	System Audio during PTT/EM PTT	Output	Galvanically balanced audio output	0dBu	230 Ω
47 – 48	EXT. PA IN (AUDIO)	System Audio for external Paging	Input	Galvanically balanced audio input	0dBu	15 kΩ
49 – 50	PA1 / 0V	Direct Paging inputs	Input	Dry contact input	≈20VDC	2 mA
51 – 52	PA2 / 0V				≈20VDC	2 mA
53 – 54	PA3 / 0V				≈20VDC	2 mA
55 – 56	PA4 / 0V				≈20VDC	2 mA
57 – 58	PA5 / 0V				≈20VDC	2 mA
59 – 60	PA6 / 0V				≈20VDC	2 mA
61 – 62	PA7 / 0V				≈20VDC	2 mA
63 – 64	PA8 / 0V				≈20VDC	2 mA
65 – 66	+24V / 0V	Power output	Output	Power supply output	24VDC	140 mA
67 – 68	--	Not in Use	--	--	--	--
69 – 70	--	Not in Use	--	--	--	--
71 – 72	+24V / EM PA	EM PTT is active	Output	Open collector source/sink	24VDC	40 mA
73 – 74	--	Not in Use	--	--	--	--
75 – 76	--	Not in Use	--	--	--	--
77 – 78	--	Not in Use	--	--	--	--
79 – 80	B-SYSTEM SENSOR	Shorted when system is System B in a dual system configuration	Input	Dry contact input	≈20VDC	2 mA
81 – 82	POWER	USER INTERFACE 1	Output	Power supply output	24VDC	140 mA
83 – 84	AUDIO		Input	Electronically balanced audio input	2Vrms	15k Ω
85 – 86	RS485		Bidirectional	Data communication tranceiver channel RS485	5V	100 Ω

Doc.No.: 03118-000-DE

Terminals	Name	Description	Input/output	Interface	Voltage	Current / Impedance
87 – 88	POWER	USER INTERFACE 2	Output	Power supply output	24VDC	140 mA
89 – 90	AUDIO		Bidirectional	Electronically balanced audio input	2Vrms	15k Ω
91 – 92	RS485		Bidirectional	Data communication transceiver channel RS485	5V	100 Ω
93 – 94	POWER	USER INTERFACE 3	Output	Power supply output	24VDC	140 mA
95 – 96	AUDIO		Bidirectional	Electronically balanced audio input	2Vrms	15k Ω
97 – 98	RS485		Bidirectional	Data communication transceiver channel RS485	5V	100 Ω
99 – 100	POWER	USER INTERFACE 4	Output	Power supply output	24VDC	140 mA
101 – 102	AUDIO		Bidirectional	Electronically balanced audio input	2Vrms	15k Ω
103 – 104	RS485		Bidirectional	Data communication transceiver channel RS485	5V	100 Ω
105 – 106	POWER	USER INTERFACE 5	Output	Power supply output	24VDC	140 mA
107 – 108	AUDIO		Bidirectional	Electronically balanced audio input	2Vrms	15k Ω
109 – 110	RS485		Bidirectional	Data communication transceiver channel RS485	5V	100 Ω
111 – 112	POWER	USER INTERFACE 6	Output	Power supply output	24VDC	140 mA
113 – 114	AUDIO		Bidirectional	Electronically balanced audio input	2Vrms	15 kΩ
115 – 116	RS485		Bidirectional	Data communication transceiver channel RS485	5V	100 Ω
117 – 118	TX A/B	Communication link between System A & B for synchronization purposes	Output	Data communication output RS485	5V	100 Ω
119 – 120	RX A/B		Input	Data communication input RS485	5V	100 Ω
121 – 122	--	Not in Use	--	--	--	--
123 – 124	--	Not in Use	--	--	--	--
125 – 126	AUDIO	MIC. STATION 1	Input	Electronically balanced audio input	10 mV	5 kΩ
127 – 128	PTT (PA)			Dry contact input	≈20 VDC	2 mA
129 – 130	GC (EM PA)			Dry contact input	≈20 VDC	2 mA
131 – 132	AUDIO	MIC. STATION 1	Input		10 mV	5 kΩ
133 – 134	PTT (PA)			Dry contact input	≈20 VDC	2 mA
135 – 136	GC (EM PA)			Dry contact input	≈20VDC	2 mA
137 – 138	Z1 / +24V	Volume Override control outputs	Output	Open collector source/sink	24VDC	40 mA
139 – 140	Z2 / +24V			Open collector source/sink	24VDC	40 mA
141 – 142	Z3 / +24V			Open collector source/sink	24VDC	40 mA
143 – 144	Z4 / +24V			Open collector source/sink	24VDC	40 mA
145 – 146	Z5 / +24V			Open collector source/sink	24VDC	40 mA
147 – 148	Z6 / +24V			Open collector source/sink	24VDC	40 mA
149 – 150	SPARE 0V	O V reference	Reference		0V	--
151 – 152	--	Not in Use	--	--	--	--
153 – 154	--	Not in Use	--	--	--	--
155 – 156	--	Not in Use	--	--	--	--
157 – 158	--	Not in Use	--	--	--	--
159 – 160	--	Not in Use	--	--	--	--

All cables used for external interfaces are to be twisted pair, outer screen, 0.75 mm² minimum.

6.1. GENERAL ALARM INTERFACE TO SHIPS WHISTLE / SIREN

In order to use the ships whistle as a part of the General Alarm system the MPA 1600 is providing a dry closing contact (NO) output that generates a control output signal synchronised with the GA tone sequence. Ref. document 03118-025-EC.

6.2. MUTE OF EXTERNAL GENERAL ALARM DURING EMERGENCY PA

During an active Emergency PA the MPA 1600 outputs a dry closing contact (NO) output as a mute signal for an alternative external GA system. This signal is activated together with the internal GA mute functionality.

Ref. documents: Ref. documents 03118-025-EC and 03118-000-OP, Section 2 (OPERATING DESCRIPTION) / Chapter 2.1 (Emergency Paging)

6.3. GENERAL ALARM WARNING (FLASHING) LIGHT

An active General Alarm in the MPA 1600 system is also indicated with a dry closing contact (NO) output for activation of external GA warning lights. This is mandatory in high noise environments. Ref. document 03118-025-EC.

6.4. ENTERTAINMENT MUTE, PA/GA

In case the MPA 1600 system has integrated entertainment functionality or this is an external system this is of very low priority and shall be muted during GA and Emergency PA. The internal MPA 1600 mute functionality is working together with a dry closing contact (NO) output for external use.

Ref. documents:

- 03118-000-OP, Section 2 (OPERATING DESCRIPTION) / Chapter 2.1 (Emergency Paging)
- 03118-000-OP, Section 2 (OPERATING DESCRIPTION) / Chapter 2.3 (Alarm)
- 03118-025-EC

6.5. VOLUME OVERRIDE

In addition to the entertainment mute functionality, the MPA 1600 is equipped with a volume override signal as a relay driver output (Open Collector source/sink) which is activated during both GA and Emergency PA. This signal is used for resetting local entertainment (etc.) volume control settings related to the GA/PA system.

Ref. documents:

- 03118-000-OP, Section 2 (OPERATING DESCRIPTION) / Chapter 2.1 (Emergency Paging)
- 03118-000-OP, Section 2 (OPERATING DESCRIPTION) / Chapter 2.3 (Alarm)
- 03118-025-EC

6.6. POWER FAILURE

The MPA 1600 is supplied from two different sources: primary and backup. The system is equipped with a dry closing contact (NO & NC) output that is activated whenever one of these sources fail, either primary or backup. This signal can either be used as an interface to external surveillance and monitoring systems or for direct signals, as rotating/flashing lights or light columns.

Ref. document 03118-025-EC.

6.7. GENERAL WARNING

The MPA 1600 system is equipped with a general warning dry closing contact (NO) output. This control output can be used as an interface to external surveillance and monitoring systems for indication of system internal module failure indications:

- The synchronisation link between system A and B is defect
- A control unit is defect or disconnected
- Amplifier failure (in case the system is equipped with the optional amplifier failure detection module)

Ref. document 03118-025-EC.

MPA 1600 SYSTEM PA / GA INSTALLATION PROCEDURE

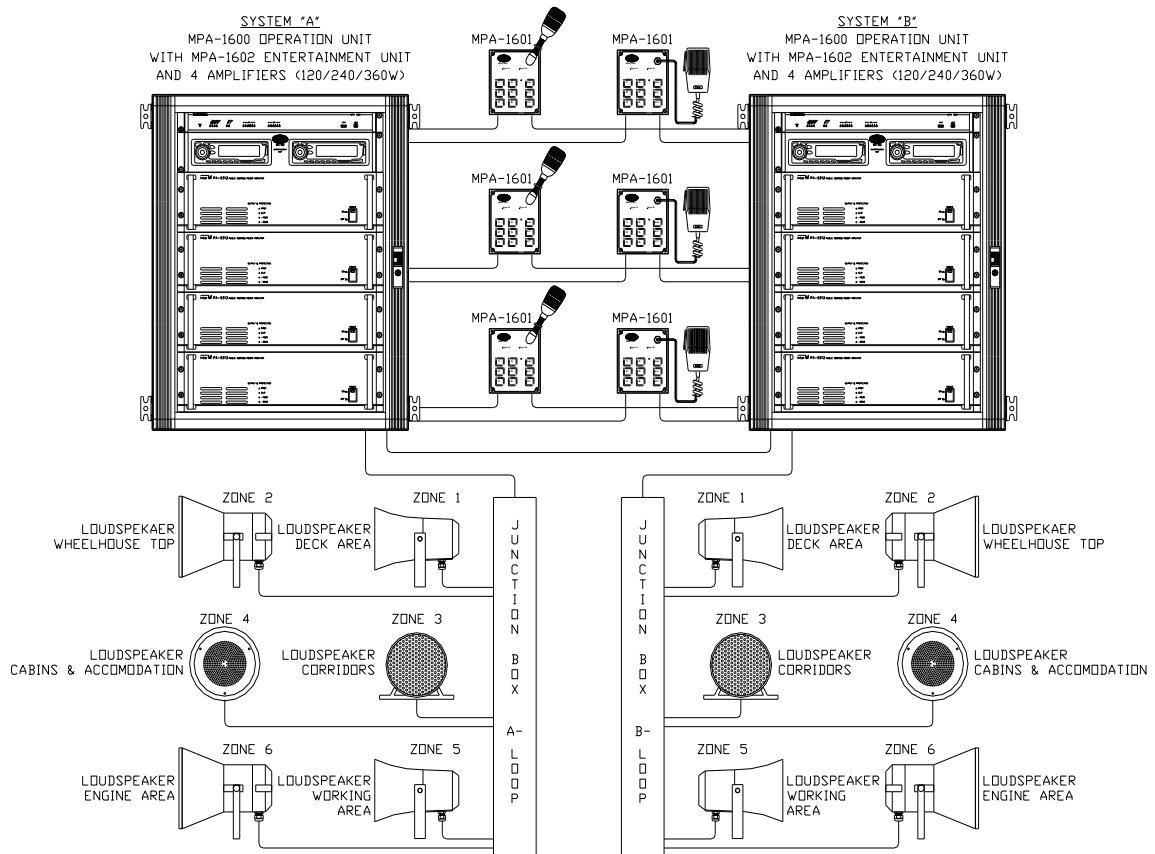

CONTENTS

CONTENTS	2
1 INTRODUCTION.....	3
1.1 PA CONFIGURATION, CARGO VESSELS	3
1.2 PA CONFIGURATION, PASSENGER VESSELS.....	3
1.3 PA/GA CONFIGURATION, ALL VESSELS.....	3
1.4 TYPE NUMBER / SYSTEM IDENTIFICATION	3
2 INSTALLATION GUIDE	3
2.1 PLANNING.....	3
2.1.1 General	3
2.1.2 Loudspeaker selection / SPL	7
2.1.3 Amount of loudspeakers.....	7
2.1.4 Cable arrangement.....	7
2.1.5 Zones	8
2.1.6 Amplifiers.....	8
2.1.7 Short Circuit proof loudspeakers.....	9
2.1.8 Compass Safe Distance:	9
2.2 GENERAL ALARM ADJUSTMENT	9
2.3 FEEDBACK / INTERFERENCE CANCELLATION.....	10
2.3.1 Local Mute	10
2.3.2 Speech delay.....	10
2.4 POWER	11
2.5 GLANDS	11
2.6 FERRULING	11
2.7 MARKING	11
2.8 FASTENING	11
2.9 PRESERVATION	11
2.10 CABLE REQUIREMENTS.....	12

1 INTRODUCTION

The MPA 1600 system is a marine and offshore Public Address and General Alarm system. It meets the requirements for PA/GA, and entertainment, distribution onboard ships and mobile offshore units. The system conforms to SOLAS, IMO and IEC regulations. Based on modular design and flexible configuration, it covers a wide range of installation complexities. Ranging from, small single loop systems, to large duplicated systems.

1.1 PA CONFIGURATION, CARGO VESSELS

In MPA 1600 system onboard cargo vessels and where GA is not integrated into the PA system there, is no requirement for a duplicated system. All loudspeaker loops however shall be arranged as closed loops.

1.2 PA CONFIGURATION, PASSENGER VESSELS

In MPA 1600 system onboard passenger vessels, the requirement is a duplicated system in order to minimize the effect of one single failure. The centralised duplicated equipment (operation unit and amplifiers) must be separated and located in different fire zones. The loudspeaker loops from each system is to be segregated throughout the ship.

All loudspeaker loops shall be arranged as closed loops.

1.3 PA/GA CONFIGURATION, ALL VESSELS

In MPA 1600 system onboard cargo vessels and where GA is integrated into the PA system as a combined PA/GA system the requirement for duplication is the same as for Pa systems onboard passenger vessels as described above. (Ch. 1.2)

1.4 TYPE NUMBER / SYSTEM IDENTIFICATION

In order to recognise and identify different version of an MPA1600 system there is an identification system marked on all cabinets.

2 INSTALLATION GUIDE

2.1 PLANNING

The installation should be planned in details before commencing. Sound pressure levels and amount of loudspeakers must be decided. The cables should be listed in a cable plan, with number of pairs etc. The location of each unit in the communication system should be planned to obtain maximum performance and user availability.

2.1.1 General

The major requirement of a GA / PA system is sufficient coverage and sound pressure level (SPL) for alarms and PA messages to be heard throughout the installation.

The minimum requirement during normal operating conditions for GA is 80dBA and at least 10dBA above the ambient noise level in both interior and exterior spaces. In the cabins sleeping positions and bathroom the minimum requirement is 75dBA and at least 10dBA above the ambient noise level.

For PA (Emergency PA) the minimum figures are 75dBA and at least 20 dBA above the speech interference level for interior spaces. For exterior spaces the minimum requirement is 80 dBA and at least 15 dBA above the speech interference level.

To ensure this, the MPA 1600 system makes use of the industrial standardized 100 V line distribution system. This is a distribution system that is based on a fixed line level (100V) and where the loudspeaker output power is determined by means of loudspeaker type and power tapping. Hence, each loudspeaker meeting this line specification is equipped with an audio transformer with several tapping possibilities.

In a system like this where the amount of loudspeakers, loudspeaker types (power rating) and tapping decides the coverage and sound pressure.

To comply with the environment requirement all loudspeakers used in a PA / GA system must be approved according to relevant parts of IEC60945 or similar.

Typical loudspeaker data sheets (next page):

DNH CAR6T:



DNH
N-3770 Kragero
NORWAY
Phone: (47) 35 98 56 00
Fax: (47) 35 98 56 10
E-mail: dnh@dnh.no
Web-site:..... www.dnh.no

ISO 9001 CERTIFIED

CAR-6(T)

DNH WW Ltd. England Phone:(44) 1908 275 000
Fax:(44) 1908 275 100
E-mail: dnh@dnh.co.uk

DNH GmbH Germany Phone: (49) 040 6569 30-0
Fax:(49) 040 6569 30-30
E-mail: dnh@dnh.de

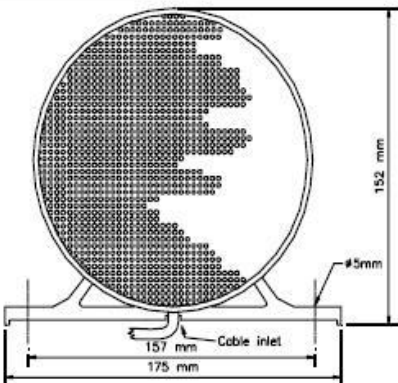

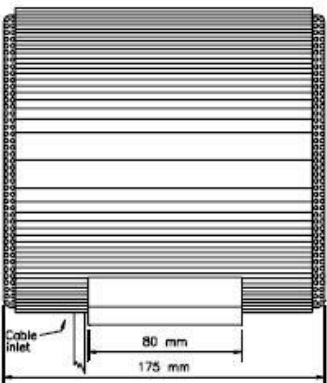

Transformer:
100 Volt line

Primary nominal
tappings:

1 : 2	6,0 W
2 : 3	3,0 W
3 : 4	1,5 W
1 : 3	1,0 W
2 : 4	0,5 W
1 : 4	0,3 W

1 = Red, 2 = Yellow
3 = Green, 4 = Blue

1W/1m sine wave smooth 1/3 octave
dB SPL vs Freq

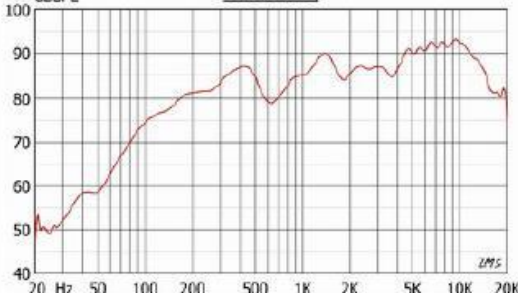

Freq (Hz)	SPL (dB)
20	50
50	60
100	70
200	75
500	85
1K	80
2K	85
5K	90
10K	90
20K	80

Material / Colour	Aluminium / RAL9010 or anodized
Mounting	Foot bracket
Termination	Cable, 1m
Weight	2,3 kg
IP-rating	
Max. / min. amb. temp	90 °C / -40 °C
Standard version	100 V transformer
Rated / max. power	6 W / 10 W
SPL 1W/1m	90 dB
SPL rated power	96 dB
Effective freq. range	150 – 20000 Hz
Dispersion (-6dB) 1kHz / 4kHz	150° / 150°
Directivity factor, Q (2kHz)	14,6

Installation, Operation and Maintenance Procedures

- Fasten loudspeaker with two screws through foot bracket.
- For optimum performance, always use the correct voltage / power and operate within the frequency limits as stated.
- This loudspeaker is supplied with a 2 year warranty against defective workmanship.

Most of our products are available in different colours, impedances and power ratings.



DNH reserves the right to alter specifications without notice.

Rev. 28.04.2004

\\nsrver2\dataark_2000\DOC-format\PROJECTOR\ProjectorMetal\CAR6T.doc

Fig. 2.1

DNH HP15T:



DNH
N-3770 Kragerø
NORWAY
Phone: (47) 35 98 56 00
Fax: (47) 35 98 56 10
E-mail: dnh@dnh.no
Web-site:..... www.dnh.no

ISO 9001 CERTIFIED

HP-15(T)

DNH WW Ltd. Phone:(44) 1908 275 000
England Fax:(44) 1908 275 100
E-mail: dnh@dnh.co.uk

DNH GmbH Phone: (49) 040 6569 30-0
Germany Fax:(49) 040 6569 30-30
E-mail: dnh@dnh.de

Bracket and all outside nuts and bolts in stainless steel

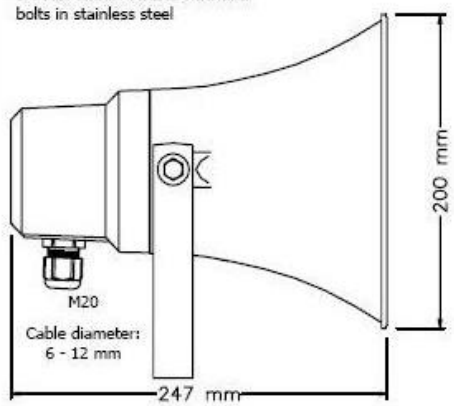

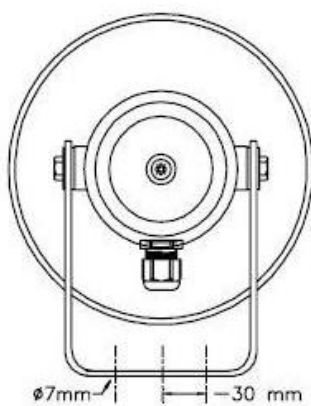

50/100 volt Combined Transformer:

Primary connections:
5 : 6 50 Volt line
5 : 8 100 Volt line

Secondary nominal tapings:
1 : 4 15,0 W
1 : 3 7,5 W
2 : 4 5,0 W
1 : 2 4,0 W
3 : 4 2,0 W
2 : 3 0,8 W

1W/1m Sine wave smooth 1/3 octave

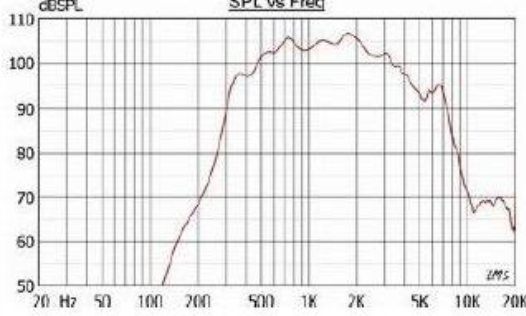

Material / Colour ABS / RAL 7035
Mounting Bracket
Termination Inside screw connections
Weight 1,7 kg
IP-rating 56
Max. / min. amb. temp 90 °C / -50 °C
Standard version 50 V / 100 V transformer
Rated / max. power 15 W / 20 W
SPL 1W/1m 108 dB
SPL rated power 118 dB
Effective freq. range 330 – 8000 Hz
Dispersion (-6dB) 1kHz / 4kHz 130° / 35°
Directivity factor, Q (2kHz) 8,3

Installation, Operation and Maintenance Procedures

- When mounting the loudspeaker please ensure that it is re-assembled in the same manner in which it was received.
- To change the position of the loudspeaker please adjust the bracket (by loosening / tightening the screws) as required.
- For optimum performance, always use the correct voltage / power and operate within the frequency limits as stated.
- Do not open loudspeaker when energized.
- Fasten lid with a torque of 1 - 2 Nm.
- This loudspeaker is supplied with a 2 year warranty against defective workmanship.

Most of our products are available in different colors, impedances and power ratings.



DNH reserves the right to alter specifications without notice.

Rev. 18.02.2004

Fig. 2.2

2.1.2 Loudspeaker selection / SPL

The calculation of sound pressure level (SPL) is also dependant of distance from the loudspeaker:
The calculation is according to the formula:

$$\text{SPL} = \text{A} + (10 * \text{LOG}_{10}(\text{B})) - (20 * \text{LOG}_{10}(\text{C}))$$

where:

- SPL : Sound Pressure Level figure at a specific point [**dB**A]
A : Loudspeaker specific data - SPL figure at 1W / 1m (according to loudspeaker data sheet **dB**A]
B : Loudspeaker specific data – Output power ((tapping according to loudspeaker data sheet) [**W**]
C : Distance from the loudspeaker to the measurement point [**m**]

An example:

The mounted loudspeaker is a DNH HP15T, (108 dB_A at 1W/1m. The distance to the loudspeaker is 10m and the tapping of the loudspeaker is 4W.

The SPL in that point is calculated to:

$$\text{SPL} = 108(\text{dB}_A) + (10 * \text{LOG}_{10}(4(\text{W}))) - (20 * \text{LOG}_{10}(10(\text{m}))) = \underline{\underline{94\text{dB}_A}}$$

Note:

Under no circumstances SPL figures in available spaces are allowed to exceed 120 dB_A.

2.1.3 Amount of loudspeakers

To determine the required amount, type and tapping of loudspeakers in a MPA 1600 system it is necessary to make an installation SPL requirement chart over the site/vessel. Within this chart noise figures must be known or estimated. This, along with the environment requirement will make a basis for the loudspeaker selection.

When this is prepared, an SPL calculation can be performed to find the requirement of loudspeaker denseness. The above SPL formula must be used.

The type and amount of loudspeakers can be established. This will also include information about tapping and output power.

It is also vital to take duplication into consideration. Whenever the MPA 1600 system handles General Alarm or the vessel is intended for passenger transportation the system shall be fully duplicated (A & B system) using separately located central equipment with physically separated cables and loudspeaker segregation. All spaces shall be covered from both duplication loops.

2.1.4 Cable arrangement

In an MPA 1600 system that handles General Alarm (PA/GA) or the vessel is intended for passenger transportation each loudspeaker distribution cable shall be organised as a closed loop starting and ending at the central equipment point. This increases redundancy regarding cable problems and can make system work without disturbances during cable failure.

2.1.5 Zones

In most installation there is a requirement for dividing the system into different paging zones. The MPA 1600 has 6 zones available for paging separation. Each zone is individually controlled from the MPA 1601 / 1604 control units.

The zone selection is important for loudspeaker distribution and the cabling plan preparation.

2.1.6 Amplifiers

The amount of loudspeakers, their tapping (actual power output) and, in some cases, the zone segmentation determines the necessary amount of amplifiers in the amplifier pool.

In a fixed line level (100V) system as the MPA 1600, the requirement for amplifier power is exactly the same as the loudspeaker output figure.

During engineering of the MPA 1600 GA / PA system it is recommended to calculate 10 – 25 % headroom of the amplifier pool for installation and/or later adjustments

The available amplifiers come in 3 power output versions:

- PA 6312 – 120W output power
- PA 6324 – 240W output power
- PA 6336 – 360 W output power

Amplifier requirement calculation example:

System A (identical to B)	#	6W loudsp. (CAR 6T)	#	15W loudsp. (HP15T)	Tot. W	AMP:
Zone 1 (cabins & corridors)	20	1,5W			30W	Amp 1: 120W
Zone 2 (crew accommodation)	10	3W	4	7,5W	60W	Amp 1: 120W
Zone 3 (working areas)	5	6W	3	15W	75W	Amp 2: 240W
Zone 4 (engine room spaces)			6	15W	90W	Amp2: 240W
Zone 5 (outdoor spaces)			15	15W	225W	Amp 3: 360W
Zone 6 (passenger spaces)	20	1,5W	4	7,5W	60W	Amp 4 : 120W

System B (identical to A)	#	6W loudsp. (CAR 6T)	#	15W loudsp. (HP15T)	Tot. W	AMP:
Zone 1 (cabins & corridors)	20	1,5W			30W	Amp 1: 120W
Zone 2 (crew accommodation)	10	3W	4	7,5W	60W	Amp 1: 120W
Zone 3 (working areas)	5	6W	3	15W	75W	Amp 2: 240W
Zone 4 (engine room spaces)			6	15W	90W	Amp2: 240W
Zone 5 (outdoor spaces)			15	15W	225W	Amp 3: 360W
Zone 6 (passenger spaces)	20	1,5W	4	7,5W	60W	Amp 4 : 120W

This example gives a reasonable safety margin for miscalculation and/or headroom for future adjustment:

Amp 1 : 31 % Headroom

Amp 2 : 44 % Headroom

Amp 3 : 38 % Headroom

Amp 4 : 50 % Headroom

2.1.7 Short Circuit proof loudspeakers

A 100V line adapted loudspeaker equipped with a line transformer is regarded as a protection against loudspeaker short circuit and is required in all installations (independent of type of vessel).

2.1.8 Compass Safe Distance:

In order to not cause any unacceptable deviation of the ships standard and steering compasses or magnetometer, the nearest point of the unit and the centre of the compass or magnetometer can not be less than:

Compass Safe Distance in cm:			
	Cabinet	Control Unit MPA 1601 / 1604	GA Alarm Panel MPA 1603
Standard	340	80	60
Steering	220	50	40

2.2 GENERAL ALARM ADJUSTMENT

The MPA 1600 system has a facility for both curve form and frequency adjustment of the General Alarm. This is a part of the system setup and must be determined either in the factory (FAT) or during System installation and commissioning. The configuration is done by means of an USB stick containing the MPA 1600 Config file (text file editor generated). This USB stick is loaded into the front USB port of the MPA 1600 Operation unit (see figure below).

The MPA Configuration is set up with the reference to the file name of the General Alarm sequence specification.

The frequency can be changed between 200 to 2500Hz and the Curve form can either be sinusoidal or triangle.

MPA 1600 Operation unit:

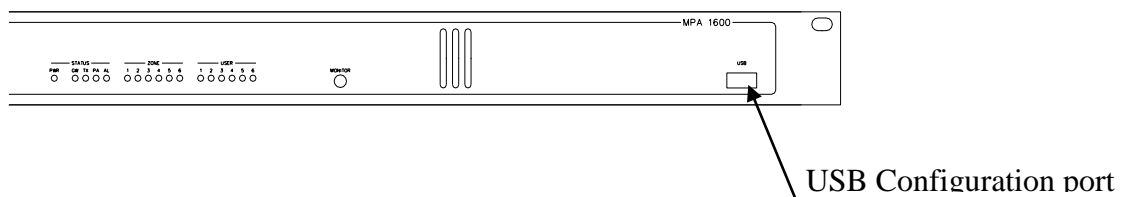

File input explanation:

GA alarm:

xxxx,yyyy - where xxxx is the tone frequency in Hz and yyyy is duration in milliseconds

GA File Example - General Alarm (7 short/ 1 long) 1000 Hz:

1000,1000	: frequency 1000 Hz, duration 1 second	- First short burst
0,1000	: frequency 0 (no tone), duration 1 second	- Pause
1000,1000	: frequency 1000 Hz, duration 1 second	- Second short burst
0,1000	: frequency 0 (no tone), duration 1 second	- Pause
1000,1000	: frequency 1000 Hz, duration 1 second	- Third short burst
0,1000	: frequency 0 (no tone), duration 1 second	- Pause

1000,1000	: frequency 1000 Hz, duration 1 second	- Fourth short burst
0,1000	: frequency 0 (no tone), duration 1 second	- Pause
1000,1000	: frequency 1000 Hz, duration 1 second	- Fifth short burst
0,1000	: frequency 0 (no tone), duration 1 second	- Pause
1000,1000	: frequency 1000 Hz, duration 1 second	- Sixth short burst
0,1000	: frequency 0 (no tone), duration 1 second	- Pause
1000,1000	: frequency 1000 Hz, duration 1 second	- Seventh short pause
0,1000	: frequency 0 (no tone), duration 1 second	- Pause
1000,7000	: frequency 1000 Hz, duration 7 seconds	- Long burst
0,1000	: frequency 0 (no tone), duration 1 second	- Pause

The system configuration file interpreter will automatically repeat the given sequence as long as the General Alarm is running.

This tone frequency and curve form alteration facility is a configuration selection only open to Zenitel or authorized personnel.

2.3 FEEDBACK / INTERFERENCE CANCELLATION

In cases where loudspeakers are placed in the near proximity of the MPA 1601 / 1604 Control units (microphones) there is a possibility of causing audible feedback making PA messages difficult or impossible to interpret. The MPA 1600 PA/GA system has two different countermeasures in order to deal with this. Either a local mute facility in each MPA 1601 Control Unit, or using a temporary recording facility within the system in order to first make a record, then automatically replay the message when finished. The latter is called speech delay and it is a configuration matter

2.3.1 Local Mute

In all Control Units, MPA 1601 / 1604 there is a "local mute" relay and related terminals. The local loudspeakers object to the mute function must be connected through this relay. As long as the Control unit is idle the relay are closed and all signal messages are passing through to the local loudspeakers. Whenever the Control unit is active (PA / Emergency PA) the relay opens and the message is disconnected from the loudspeaker and it is locally muted. Whenever the Control Units becomes idle again the loudspeaker is reconnected.

For connection details: Ref. Document 03118-025-EC

2.3.2 Speech delay

The MPA 1600 system has a facility named speech delay. When this facility is enabled in the system configuration, the MPA 1600 system will not immediately output the message when a PA or Emergency PA announcement is activated, but start a temporary recording. When the PA / Emergency PA announcement is finished the system automatically replays the message into the loudspeaker network in the selected zones (according to the initiated zone selection).

The speech delay facility is selected individually per input during installation or previously in a FAT situation. It is not object to any user selection. Once selected, it will be enabled for all messages inserted through this input. It is not dependant of any special or additional connections within the system.

The Speech delay is a configuration selection only open to Zenitel or authorized personnel.

2.4 POWER

The operating power is 115/230 VAC as primary, and 24VDC as backup. The MPA 1600 system will automatically switch between primary and secondary power source in case of mains failure. The 24VDC must be permanently present for mains transaction backup supply in order to avoid the system boot sequence of approximately 30 seconds. The system is unavailable for operation during the boot sequence.

As an optional safety precaution, the mains operating power may be pre-switched by means of a mechanical contactor/switch-over module as long as the 24VDC backup supply is present to keep the system from power fail during the switching period.

2.5 GLANDS

The cables enter the WP units by means of cable glands. Where cable glands are not supplied from factory, the installer must adapt the glands to the actual cable outer diameter. This is to obtain the specified inlet protection.

2.6 FERRULING

The conductors should be ferruled prior to termination onto the screw terminals.

2.7 MARKING

Each cable is to be marked with cable numbers.

Each conductor is to be marked with the specific termination numbers.

2.8 FASTENING

Where applicable, the cables and the conductors shall be clamped to the structure with cable ties.

2.9 PRESERVATION

Prior to, during, and after installation the equipment must be handled with care. And protected against acid holding fluids, pollution, moist, impacts etc.

This is in order to avoid damaged equipment, for which Zenitel will claim void warranty.

2.10 CABLE REQUIREMENTS

All cables used in the MPA system must be of approved ship cable type.

Requirements:

Common outer screen

Individually twisted pairs

Recommended conductor size is 0.75 mm²

All cabling in the MPA must be a separate network.

Do not combine different systems in the same cable. This is to prevent disturbance and noise caused by interference.

SCREEN CONNECTION

In order to obtain maximum performance after installation, it is necessary to terminate the cables and ground the screens in a good manner. The cables are to be de-isolated by removing approximately 500 mm of the outer insulation. Then the screen braid is cut off approximately 30 mm longer than the outer insulation. The conductors are to be de-isolated and ferruled before they are inserted into the terminals. The outer screen is clamped to the cable fixing rails inside the cabinet. Cable ties of a conductive type (metal) are recommended for best result.

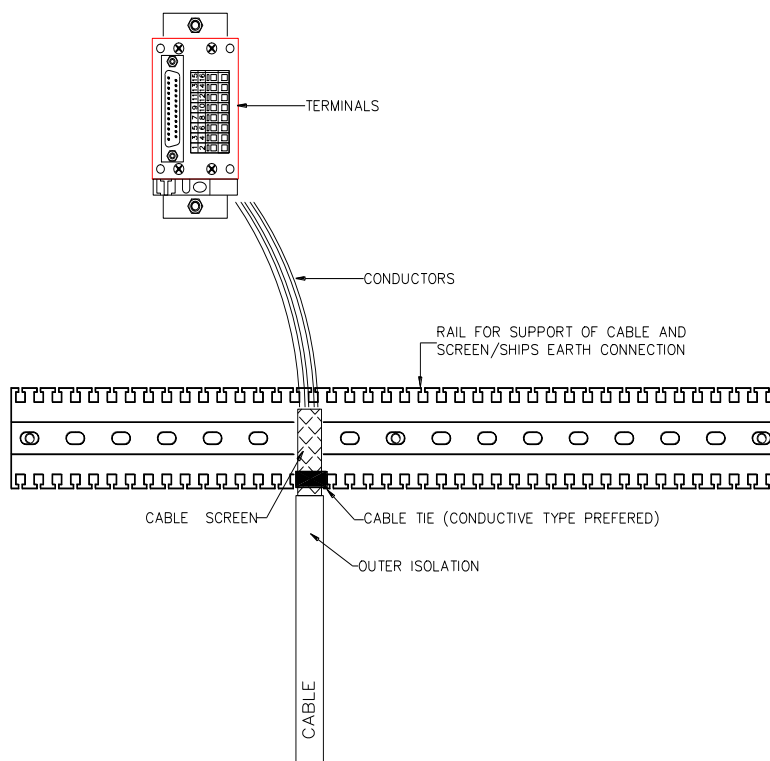
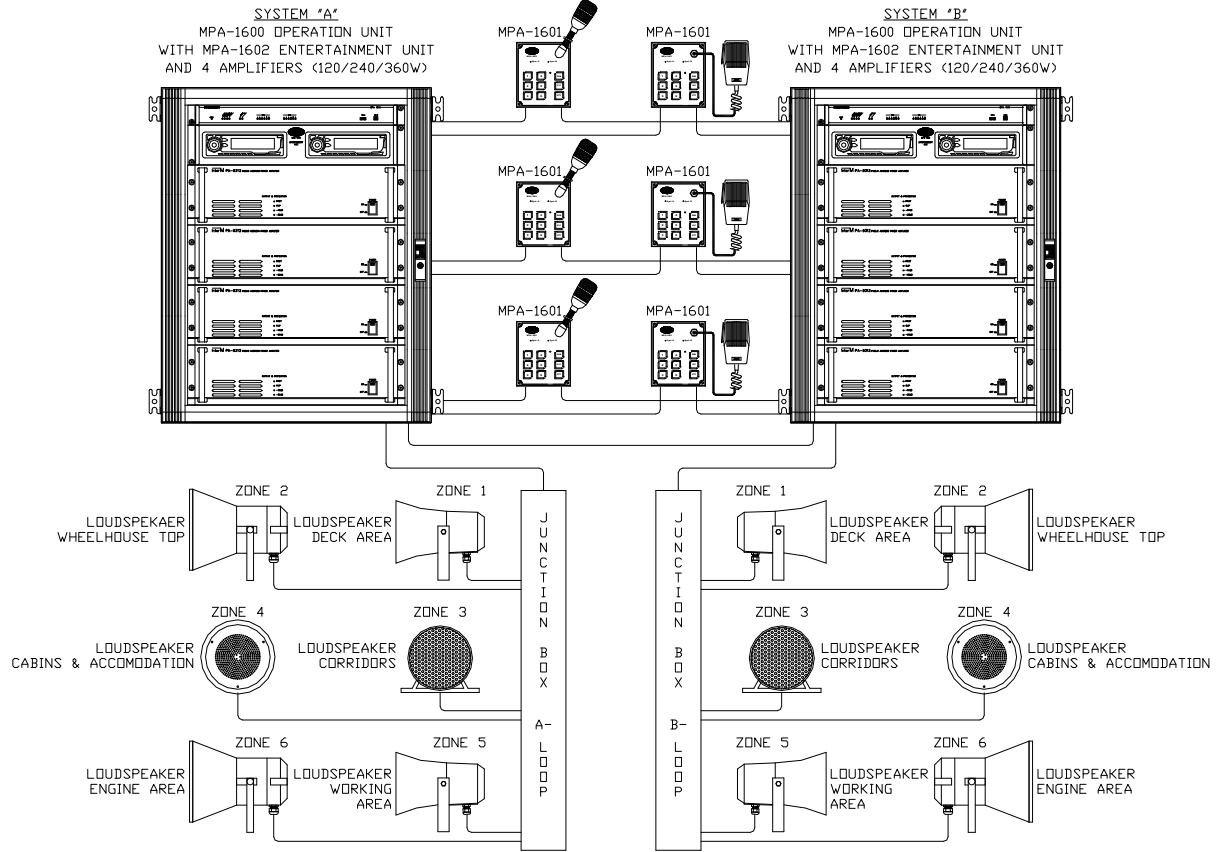

Fig. 2.3

The cable outer screens are to be terminated as shown. Conductive cable ties are recommended to obtain best possible screen connection.

MPA 1600 SYSTEM PA / GA OPERATION PROCEDURE



CONTENTS

1	INTRODUCTION	3
2	OPERATING DESCRIPTION	3
2.1	EMERGENCY PAGING	3
2.2	PAGING (Normal Paging)	4
2.3	ALARM (General Alarm)	5
2.4	PRIORITY	6
2.5	ZONES	7
2.6	LOCAL MUTE.....	7
2.7	VOLUME OVERRIDE	7
2.8	ALARM PRIORITY.	7
2.9	ATTENTION TONE	7
2.10	ENTERTAINMENT	8

1 INTRODUCTION

The MPA-system is a marine and offshore Public Address system. It meets the requirements for PA/GA, and entertainment, distribution onboard ships and mobile offshore units. The system conforms to SOLAS, IMO and IEC regulations. Based on modular design and flexible configuration, it covers a wide range of installation complexities. Ranging from, small single loop systems, to large duplicated systems. The operator panels are available in different layouts, with or without Alarm buttons. These panels are listed below:

- 1601 – Access panel with zone and EM/PA buttons, but without alarm/cancel buttons. For flush mounting.
- 1603 – Alarm panel with only alarm/cancel buttons. For flush mounting.
- 1604 – Access panel with only zone and PA buttons. For flush mounting.
- 1605 – Access panel with zone, EM/PA, and Alarm/cancel buttons. For table top mounting.
- 1606 - Access panel with zone, EM/PA, and Alarm/cancel buttons. For 19”/ flush mounting.
- 1643 - Access panel with zone, EM/PA, and Alarm/cancel buttons. For wall/desk mounting in E.X areas.

2 OPERATING DESCRIPTION

2.1 EMERGENCY PAGING

Emergency Paging (EM PA) is highest priority paging within the MPA 1600 system.

- EM PA overrides any audible entertainment channels within the system while active
- EM PA overrides any external entertainment systems by means of an entertainment signal while active (see documents 03118-100-BD and 03118-100-EC)
- EM PA overrides any volume controls (entertainment) while active
- EM PA overrides normal paging (PA)
- EM PA overrides General Alarm (GA) and other audible alarms while active
- EM PA overrides external GA systems by means of an external GA mute signal while active (see documents 03118-100-BD and 03118-100-EC)
- EM PA messages are always broadcasted to all zones/areas in the system.

Emergency paging is initiated from the Control unit MPA 1601, 1605, 1606, or 1643 by means of the EMERGENCY PA (EM PA) button. This button is marked by red colour.

To avoid unauthorised use, the EM PA button must be continuously activated (held) for one second to activate. The EM PA button must be continuously pressed during activation.

The emergency paging is released when the EM PA button is released.
During EM PA the individual zone buttons are disabled and will not affect the paging zone extent.

Figure 2-1

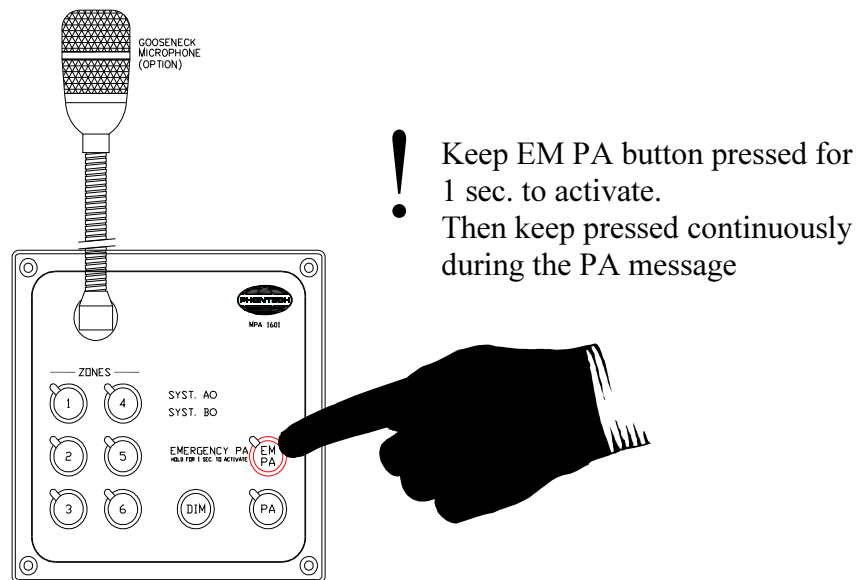

In case the General Alarm is initiated during an existing Emergency PA, the Emergency PA announcement will be interrupted and the General Alarm will be heard.
To re-establish Emergency PA as highest priority, the interrupted operator must **re-activate** the Emergency PA button. This can be done immediately.

2.2 PAGING (Normal Paging)

- PA overrides any audible entertainment channels within the system while active
- PA overrides any external entertainment systems by means of an entertainment mute signal while active (see documents 03118-100-BD and 03118-100-EC)
- PA overrides any volume controls (entertainment) while active
- PA messages can be zone controlled by means of the zone buttons for paging in separate areas. (Activate Zone buttons before PA button; green led is ON.)
- PA activation without zone control will launch the message in a system pre-programmed zone selection. (normally all zones except sleeping areas)

Normal paging is initiated from the Control units MPA 1601, 1604, 1605, 1606, or 1643 by means of the PA button.

The PA button must be continuously pressed during activation.

The normal paging is released when the PA button is released.

In case a General Alarm is active, the normal paging (PA) button will automatically change to emergency PA functionality.

Normal PA can also be activated from external microphones or other similar equipment. In that case the pre-programmed zone selection is activated.

Figure 2-2

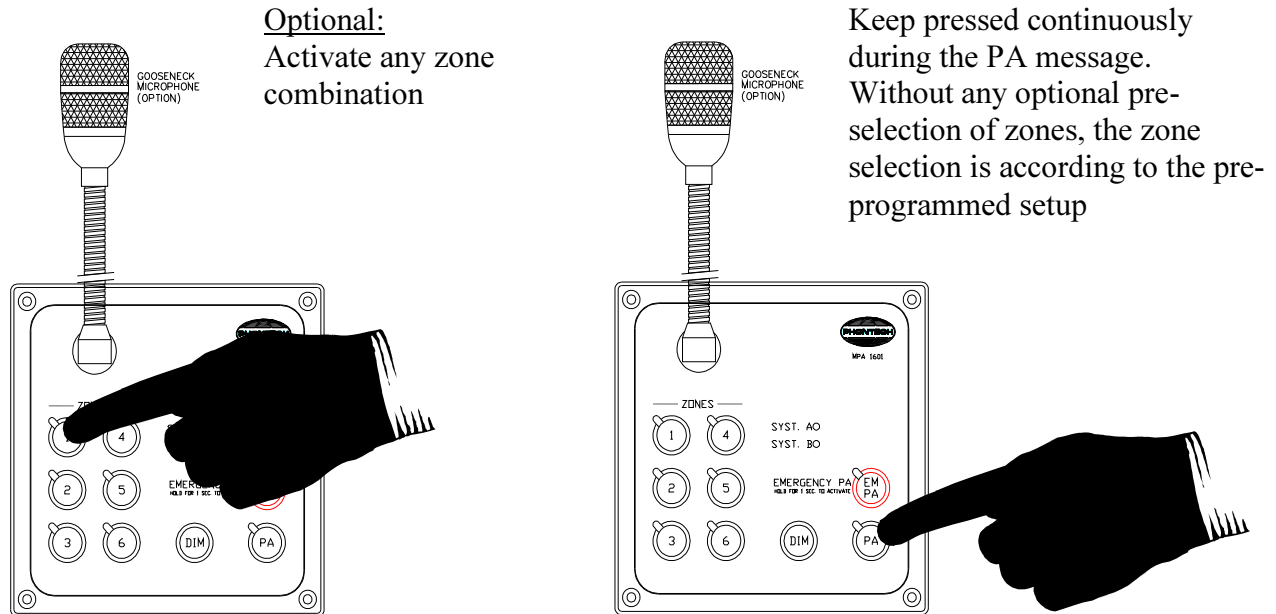

2.3 ALARM (General Alarm)

- GA overrides any other audible alarm in the system
- GA overrides any external entertainment systems by means of an entertainment mute signal while active (see documents 03118-025-EC)
- GA overrides any volume controls (entertainment) while active
- GA overrides normal paging (PA)
- GA overrides Emergency PA temporary in case EM PA is active before GA is turned on as a temporary guarantee for GA notification. (EM PA will then be able to re-activate and override GA as normal and with highest priority).
- Other system alarms (Alarm 2-4) will, if configured, behave as GA but with priority below GA.
- GA is always broadcasted to all zones/areas in the system.

The General Alarm is initiated from the MPA 1603, 1605, 1606, or 1643 by means of Alarm button 1 – GA.

This button is marked by red colour.

The GA is activated by a single push operation of the button and must be released by the Cancel (C) button.

To avoid unauthorised use, the GA button must be kept pressed for one second to activate.

Also to avoid unauthorised cancellation, the C (Cancel) button must also be kept pressed for one second to activate.

The MPA 1603, 1605, 1606 and 1643 is also equipped with 3 additional Alarm buttons for activation of optional alarms. These alarms will all have lower priority than the GA and thus be overridden whenever a GA is initiated.

Figure 2-3

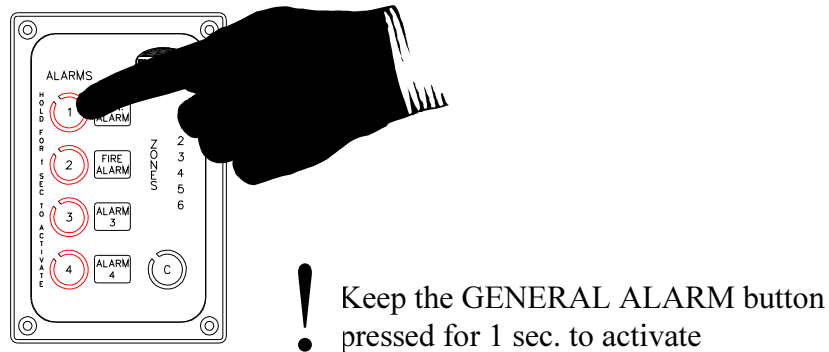

Figure 2-4



2.4 PRIORITY

The MPA 1600 system is subject to a priority configuration. This configuration is somehow flexible, but certain rules are to be maintained (highest priority on top of the list and downwards):

- Emergency PA initiated from the Bridge (MPA 1601/1605/1606/1643 – EM PA)
- Emergency PA initiated from a secondary vital position (MPA 1601/1605/1606/1643 – EM_PA)
- Emergency PA initiated from other optional positions (MPA 1601/1605/1606/1643 – EM PA)
- General Alarm (MPA 1603/1605/1606/1643)
- Additional alarms (optional) (MPA 1603/1605/1606/1643)
- Normal PA from the Bridge position (MPA 1601/1605/1606/1643 – PA)
- Normal PA from a secondary vital position (MPA 1601/1605/1606/1643 – PA)
- Normal PA from other optional positions (MPA 1601 or MPA 1604 – PA)

GA overrides Emergency PA temporary in case EM PA is active before GA is turned on as a temporary guarantee for GA notification. (EM PA will then be able to re-activate and override GA as normal and with highest priority)

- When the system is occupied the Zone buttons indicators of the Control Unit (MPA 1601 /1604/1605/1606/1643) will light up red.
- When the priority rules (above) allow override from a specific Control Unit, the Emergency PA or PA button indicators on the unit are unlit.
- When the priority rules do not allow override from a specific Control Unit, the Emergency PA or PA button indicators on the unit are lit up red

2.5 ZONES

The MPA 1600 is divided into 6 different Zones. During normal paging (not EM PA) the different areas can be selected by activating the zone keys before the PA key. Any zone combination can be selected. To disengage the selected zone selection each activated zone must be manually turned off. If the PA button is activated without any previous zone selection the pre-programmed default zone selection is activated.

2.6 LOCAL MUTE

Each MPA 1601/1604/1605/1606/ Control Unit has built-in mute relays, which will be active during paging from this user. Routing local speakers through these relays will minimize the risk of audible feedback.

2.7 VOLUME OVERRIDE

Each zone has a "volume override" output that will disable local volume settings. In an entertainment system it is convenient to have local volume controls at the loudspeaker. However, alarms and PA messages needs to be distributed at full volume and will activate this override while activated.

2.8 ALARM PRIORITY.

The General Alarm has priority over Normal PA messages and any entertainment source. The General Alarm has normally priority below Emergency PA in order to make authorised operators able to give important messages during alarm.

2.9 ATTENTION TONE

Each paging will be announced with an initial attention tone. This attention tone is different, dependant of the PA situation in order to distinguish between normal and emergency paging.

2.10 ENTERTAINMENT

The MPA1602 (optional) can have up to 2 entertainment sources. This can be either two CD-players. Or one CD-player and an external source like TV or video signals. Both sources can be distributed to any of the 6 zones. Configuration is done through the keypad on the MPA 1602 front-panel. Status in each zone is also indicated on the same keypad. Any Entertainment source is muted during PA/Emergency PA and Alarm (GA).

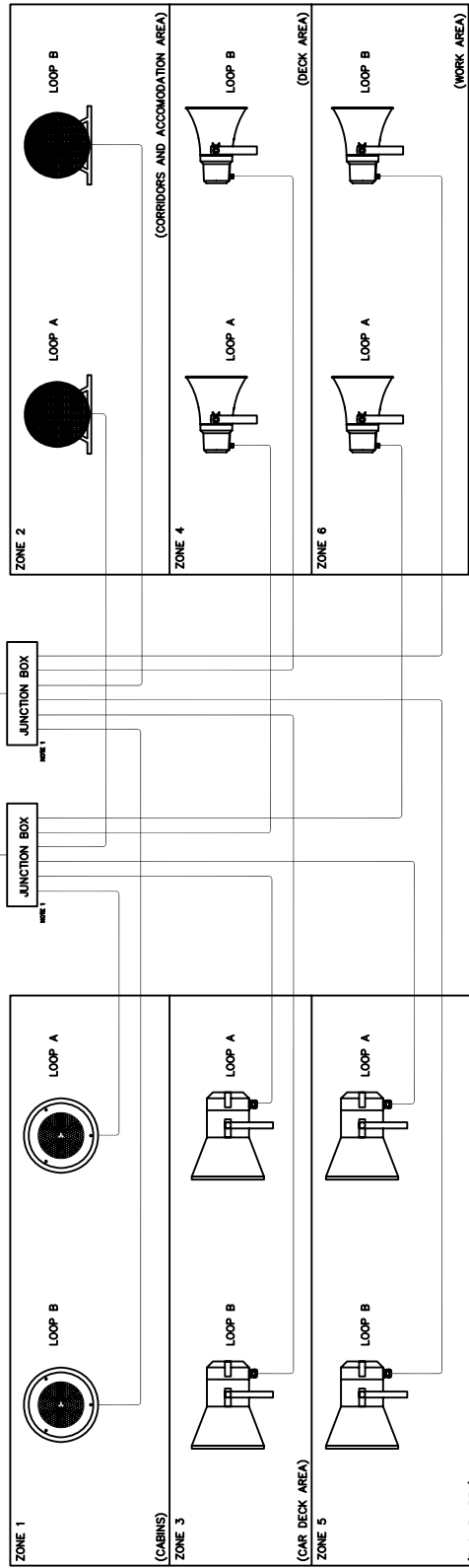
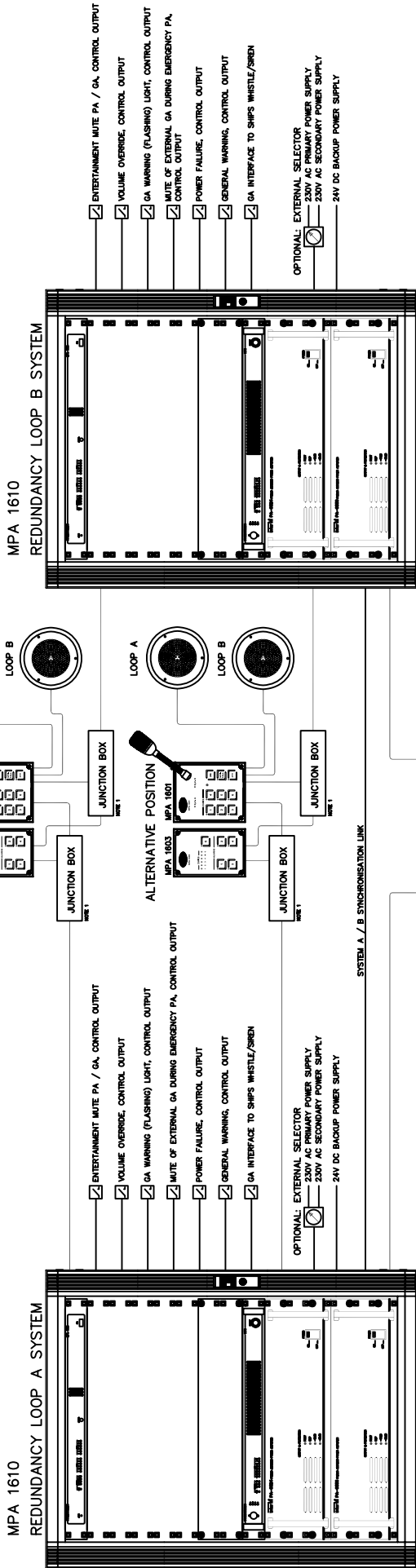

NOTE 1:
JUNCTION BOXES ARE YARD SUPPLY

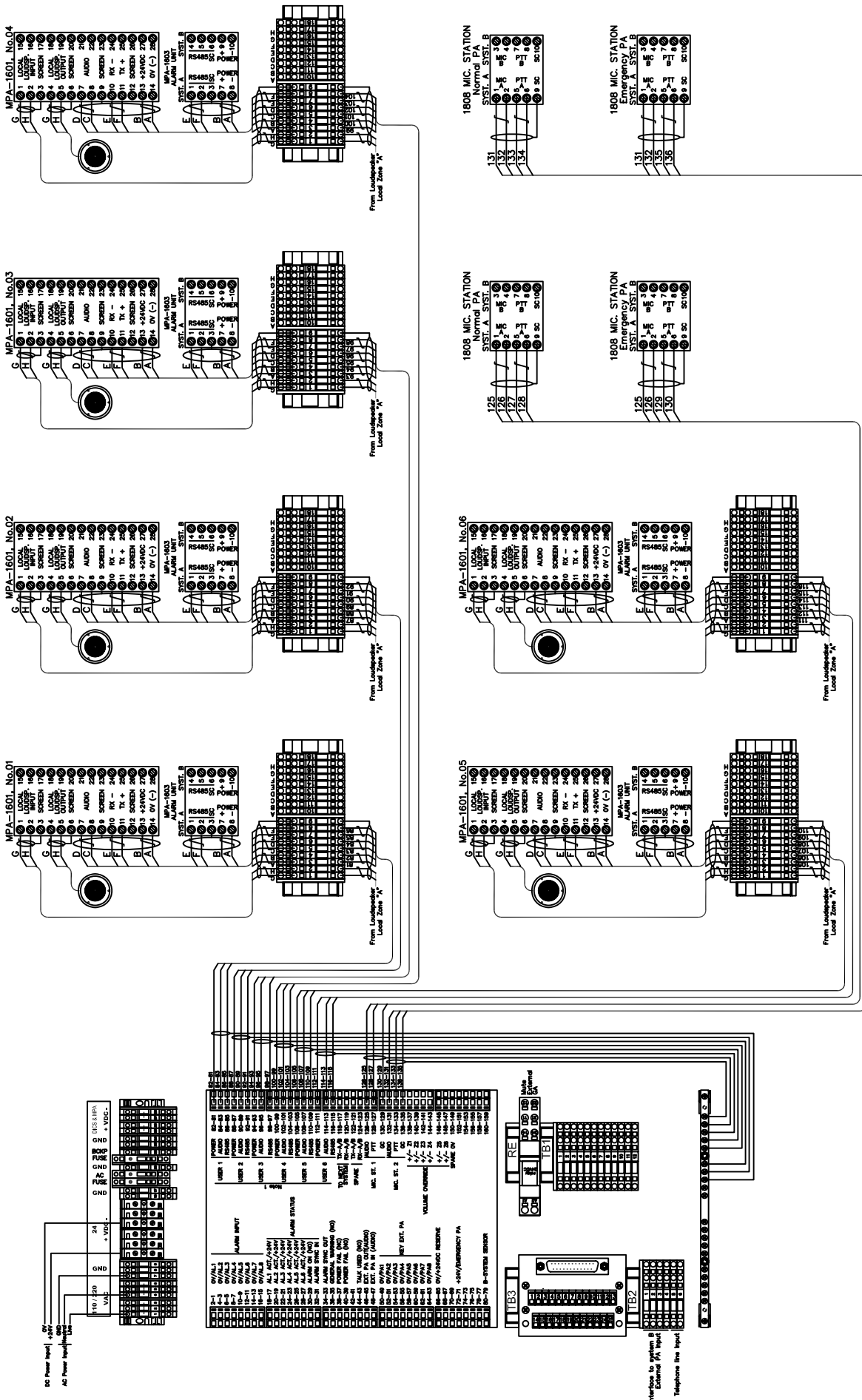

NOTE 1:
 Each USER Interface can support up to 4 Control Units, 1601/1604 and alarm panels 1603.
 Using more than One 1601/1604 will require modification to the units in order to terminate
 the RS485 Data communication interface correctly. This will be Project dependant

TB2 and TB3 are optional and/or project dependent

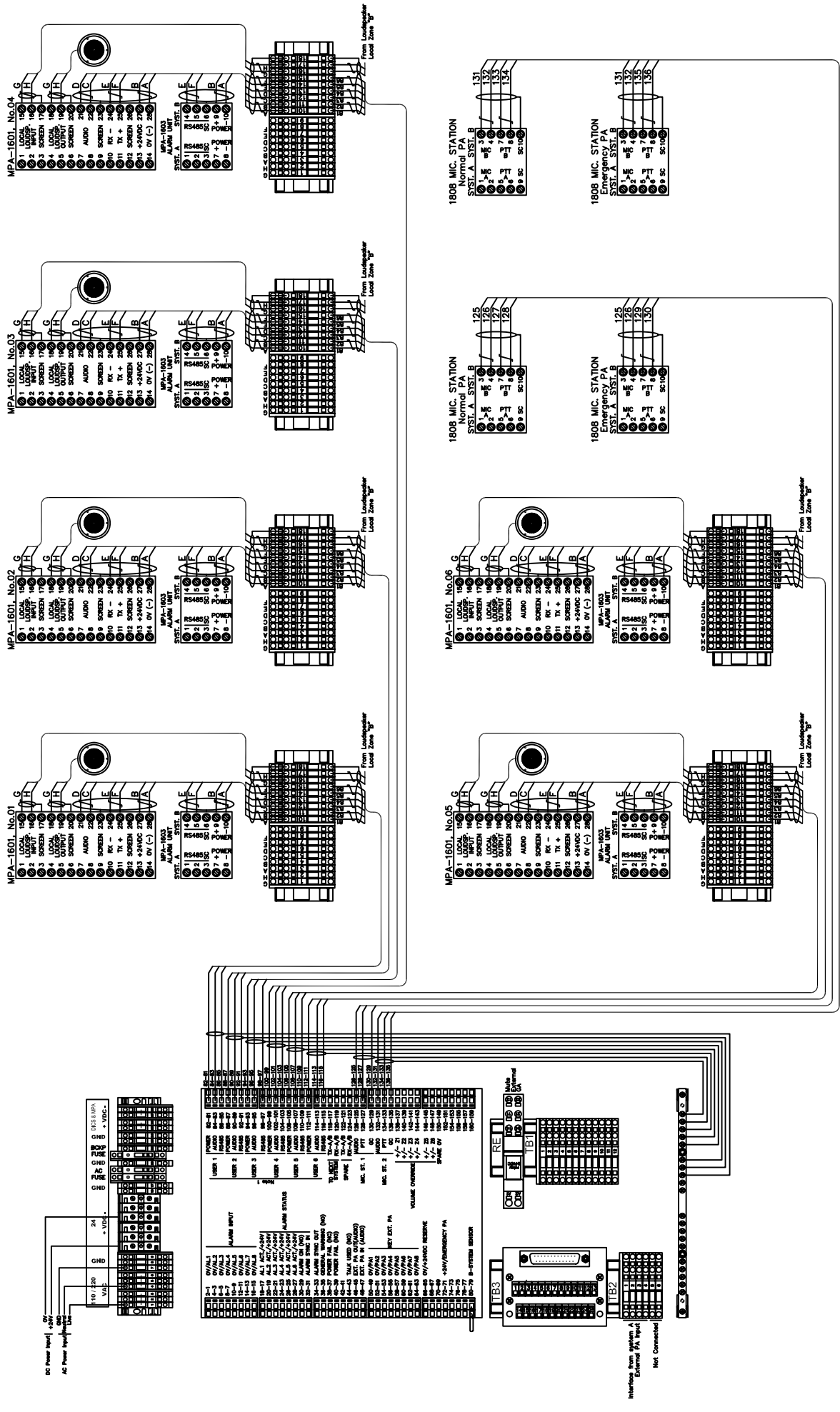

NOTE 1:
Each USER Interface can support up to 4 Control Units, 1601/1604 and alarm panels 1603.
Using more than One 1601/1604 will require modification to the units in order to terminate
the RS485 Data communication interface correctly. This will be Project dependant

TB2 and TB3 are optional and/or project dependent

ZONE 1 - CREW ACCOMMODATION

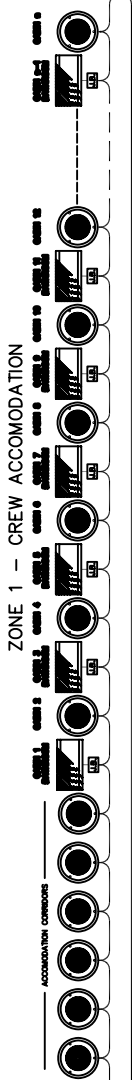

ZONE 2 - CREW AREAS

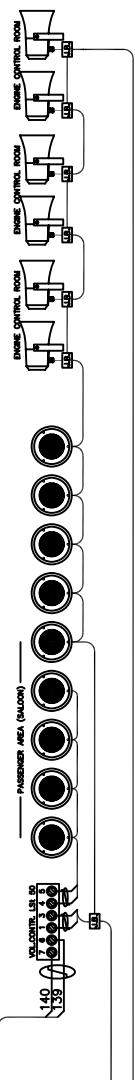

ZONE 3 - ENGINE AREAS

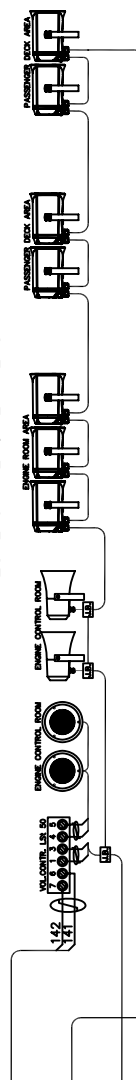

ZONE 4 - OUTDOOR AREAS

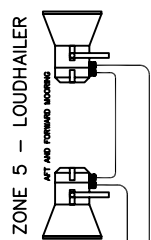
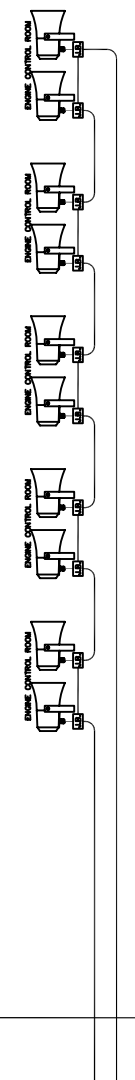

ZONE 6 - OTHER (OPTIONAL)

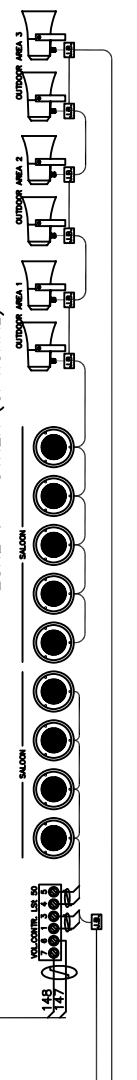

TERMINAL	DESCRIPTION	TERMINAL	DESCRIPTION
1-1	0V/WALL	101	REAR
1-2	0V/WALL	102	REAR
1-3	0V/WALL	103	REAR
1-4	0V/WALL	104	REAR
1-5	0V/WALL	105	REAR
1-6	0V/WALL	106	REAR
1-7	0V/WALL	107	REAR
1-8	0V/WALL	108	REAR
1-9	0V/WALL	109	REAR
1-10	0V/WALL	110	REAR
1-11	0V/WALL	111	REAR
1-12	0V/WALL	112	REAR
1-13	0V/WALL	113	REAR
1-14	0V/WALL	114	REAR
1-15	0V/WALL	115	REAR
1-16	0V/WALL	116	REAR
1-17	AL1 AL1 (A/9M)	117	REAR
1-18	AL1 AL1 (A/9M)	118	REAR
1-19	AL1 AL1 (A/9M)	119	REAR
1-20	AL1 AL1 (A/9M)	120	REAR
1-21	AL1 AL1 (A/9M)	121	REAR
1-22	AL1 AL1 (A/9M)	122	REAR
1-23	AL1 AL1 (A/9M)	123	REAR
1-24	AL1 AL1 (A/9M)	124	REAR
1-25	AL1 AL1 (A/9M)	125	REAR
1-26	AL1 AL1 (A/9M)	126	REAR
1-27	AL1 AL1 (A/9M)	127	REAR
1-28	AL1 AL1 (A/9M)	128	REAR
1-29	AL1 AL1 (A/9M)	129	REAR
1-30	AL1 AL1 (A/9M)	130	REAR
1-31	AL1 AL1 (A/9M)	131	REAR
1-32	AL1 AL1 (A/9M)	132	REAR
1-33	AL1 AL1 (A/9M)	133	REAR
1-34	AL1 AL1 (A/9M)	134	REAR
1-35	AL1 AL1 (A/9M)	135	REAR
1-36	AL1 AL1 (A/9M)	136	REAR
1-37	AL1 AL1 (A/9M)	137	REAR
1-38	AL1 AL1 (A/9M)	138	REAR
1-39	AL1 AL1 (A/9M)	139	REAR
1-40	AL1 AL1 (A/9M)	140	REAR
1-41	AL1 AL1 (A/9M)	141	REAR
1-42	AL1 AL1 (A/9M)	142	REAR
1-43	AL1 AL1 (A/9M)	143	REAR
1-44	AL1 AL1 (A/9M)	144	REAR
1-45	AL1 AL1 (A/9M)	145	REAR
1-46	AL1 AL1 (A/9M)	146	REAR
1-47	AL1 AL1 (A/9M)	147	REAR
1-48	AL1 AL1 (A/9M)	148	REAR
1-49	AL1 AL1 (A/9M)	149	REAR
1-50	AL1 AL1 (A/9M)	150	REAR
1-51	AL1 AL1 (A/9M)	151	REAR
1-52	AL1 AL1 (A/9M)	152	REAR
1-53	AL1 AL1 (A/9M)	153	REAR
1-54	AL1 AL1 (A/9M)	154	REAR
1-55	AL1 AL1 (A/9M)	155	REAR
1-56	AL1 AL1 (A/9M)	156	REAR
1-57	AL1 AL1 (A/9M)	157	REAR
1-58	AL1 AL1 (A/9M)	158	REAR
1-59	AL1 AL1 (A/9M)	159	REAR
1-60	AL1 AL1 (A/9M)	160	REAR
1-61	AL1 AL1 (A/9M)	161	REAR
1-62	AL1 AL1 (A/9M)	162	REAR
1-63	AL1 AL1 (A/9M)	163	REAR
1-64	AL1 AL1 (A/9M)	164	REAR
1-65	AL1 AL1 (A/9M)	165	REAR
1-66	AL1 AL1 (A/9M)	166	REAR
1-67	AL1 AL1 (A/9M)	167	REAR
1-68	AL1 AL1 (A/9M)	168	REAR
1-69	AL1 AL1 (A/9M)	169	REAR
1-70	AL1 AL1 (A/9M)	170	REAR
1-71	AL1 AL1 (A/9M)	171	REAR
1-72	AL1 AL1 (A/9M)	172	REAR
1-73	AL1 AL1 (A/9M)	173	REAR
1-74	AL1 AL1 (A/9M)	174	REAR
1-75	AL1 AL1 (A/9M)	175	REAR
1-76	AL1 AL1 (A/9M)	176	REAR
1-77	AL1 AL1 (A/9M)	177	REAR
1-78	AL1 AL1 (A/9M)	178	REAR
1-79	AL1 AL1 (A/9M)	179	REAR
1-80	AL1 AL1 (A/9M)	180	REAR
1-81	AL1 AL1 (A/9M)	181	REAR
1-82	AL1 AL1 (A/9M)	182	REAR
1-83	AL1 AL1 (A/9M)	183	REAR
1-84	AL1 AL1 (A/9M)	184	REAR
1-85	AL1 AL1 (A/9M)	185	REAR
1-86	AL1 AL1 (A/9M)	186	REAR
1-87	AL1 AL1 (A/9M)	187	REAR
1-88	AL1 AL1 (A/9M)	188	REAR
1-89	AL1 AL1 (A/9M)	189	REAR
1-90	AL1 AL1 (A/9M)	190	REAR
1-91	AL1 AL1 (A/9M)	191	REAR
1-92	AL1 AL1 (A/9M)	192	REAR
1-93	AL1 AL1 (A/9M)	193	REAR
1-94	AL1 AL1 (A/9M)	194	REAR
1-95	AL1 AL1 (A/9M)	195	REAR
1-96	AL1 AL1 (A/9M)	196	REAR
1-97	AL1 AL1 (A/9M)	197	REAR
1-98	AL1 AL1 (A/9M)	198	REAR
1-99	AL1 AL1 (A/9M)	199	REAR
1-100	AL1 AL1 (A/9M)	200	REAR

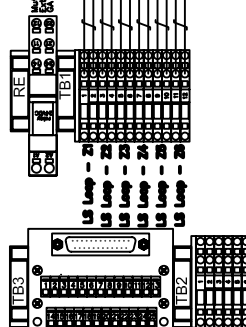

Interface to system 8
External PA Input
Telephone line input

TB2 and TB3 are optional and/or project dependent

ZONE 1 - CREW ACCOMMODATION

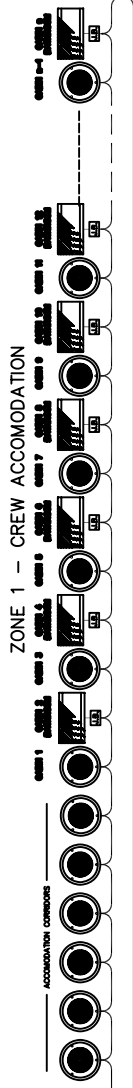

ZONE 2 - CREW AREAS



ZONE 3 - ENGINE AREAS

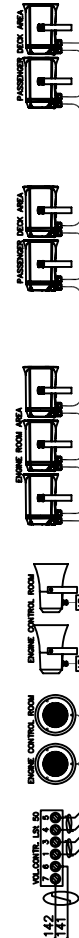

ZONE 4 - OUTDOOR AREAS



ZONE 5 - LOUDHAILER



ZONE 6 - OTHER (OPTIONAL)

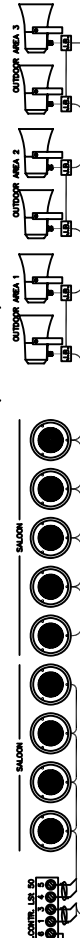

USER	DESCRIPTION	NO.	DESCRIPTION	NO.
POWER	50-51	ALARM INPUT	100-101	REAR
ALARM INPUT	100-102	ALARM STATUS	100-103	REAR
ALARM STATUS	100-104	ALARM STATUS	100-105	REAR
ALARM STATUS	100-106	ALARM STATUS	100-107	REAR
ALARM STATUS	100-108	ALARM STATUS	100-109	REAR
ALARM STATUS	100-110	ALARM STATUS	100-111	REAR
ALARM STATUS	100-112	ALARM STATUS	100-113	REAR
ALARM STATUS	100-114	ALARM STATUS	100-115	REAR
ALARM STATUS	100-116	ALARM STATUS	100-117	REAR
ALARM STATUS	100-118	ALARM STATUS	100-119	REAR
ALARM STATUS	100-120	ALARM STATUS	100-121	REAR
ALARM STATUS	100-122	ALARM STATUS	100-123	REAR
ALARM STATUS	100-124	ALARM STATUS	100-125	REAR
ALARM STATUS	100-126	ALARM STATUS	100-127	REAR
ALARM STATUS	100-128	ALARM STATUS	100-129	REAR
ALARM STATUS	100-130	ALARM STATUS	100-131	REAR
ALARM STATUS	100-132	ALARM STATUS	100-133	REAR
ALARM STATUS	100-134	ALARM STATUS	100-135	REAR
ALARM STATUS	100-136	ALARM STATUS	100-137	REAR
ALARM STATUS	100-138	ALARM STATUS	100-139	REAR
ALARM STATUS	100-140	ALARM STATUS	100-141	REAR
ALARM STATUS	100-142	ALARM STATUS	100-143	REAR
ALARM STATUS	100-144	ALARM STATUS	100-145	REAR
ALARM STATUS	100-146	ALARM STATUS	100-147	REAR
ALARM STATUS	100-148	ALARM STATUS	100-149	REAR
ALARM STATUS	100-150	ALARM STATUS	100-151	REAR
ALARM STATUS	100-152	ALARM STATUS	100-153	REAR
ALARM STATUS	100-154	ALARM STATUS	100-155	REAR
ALARM STATUS	100-156	ALARM STATUS	100-157	REAR
ALARM STATUS	100-158	ALARM STATUS	100-159	REAR
ALARM STATUS	100-160	ALARM STATUS	100-161	REAR
ALARM STATUS	100-162	ALARM STATUS	100-163	REAR
ALARM STATUS	100-164	ALARM STATUS	100-165	REAR
ALARM STATUS	100-166	ALARM STATUS	100-167	REAR
ALARM STATUS	100-168	ALARM STATUS	100-169	REAR
ALARM STATUS	100-170	ALARM STATUS	100-171	REAR
ALARM STATUS	100-172	ALARM STATUS	100-173	REAR
ALARM STATUS	100-174	ALARM STATUS	100-175	REAR
ALARM STATUS	100-176	ALARM STATUS	100-177	REAR
ALARM STATUS	100-178	ALARM STATUS	100-179	REAR
ALARM STATUS	100-180	ALARM STATUS	100-181	REAR
ALARM STATUS	100-182	ALARM STATUS	100-183	REAR
ALARM STATUS	100-184	ALARM STATUS	100-185	REAR
ALARM STATUS	100-186	ALARM STATUS	100-187	REAR
ALARM STATUS	100-188	ALARM STATUS	100-189	REAR
ALARM STATUS	100-190	ALARM STATUS	100-191	REAR
ALARM STATUS	100-192	ALARM STATUS	100-193	REAR
ALARM STATUS	100-194	ALARM STATUS	100-195	REAR
ALARM STATUS	100-196	ALARM STATUS	100-197	REAR
ALARM STATUS	100-198	ALARM STATUS	100-199	REAR
ALARM STATUS	100-200	ALARM STATUS	100-201	REAR

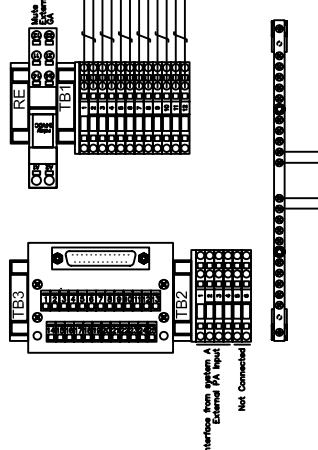

TB2 and TB3 are optional and/or project dependent

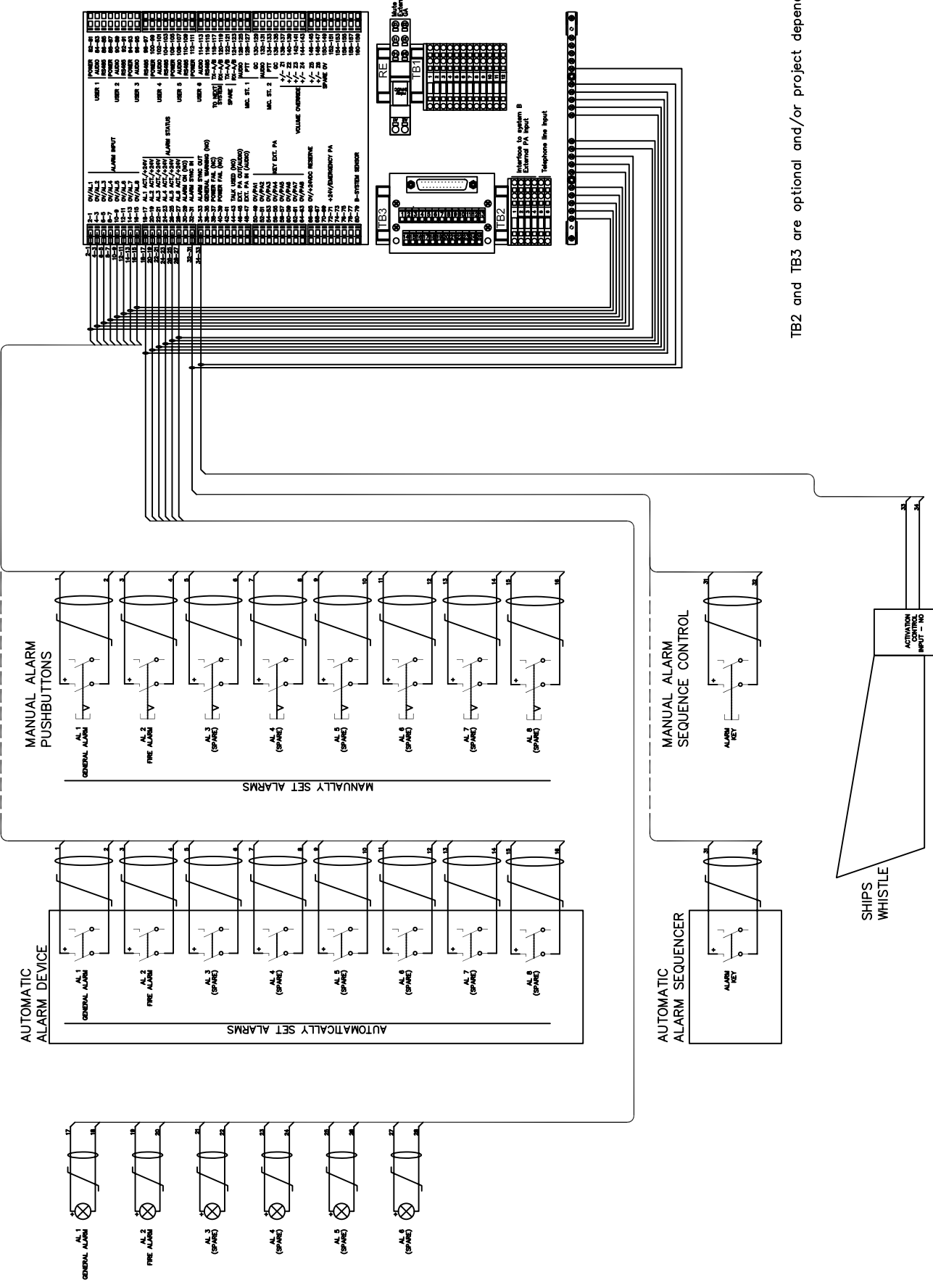

USER 1	USER 2	USER 3	USER 4	USER 5	USER 6	USER 7	USER 8	USER 9	USER 10	USER 11	USER 12	USER 13	USER 14	USER 15	USER 16	USER 17	USER 18	USER 19	USER 20	USER 21	USER 22	USER 23	USER 24	USER 25	USER 26	USER 27	USER 28	USER 29	USER 30	USER 31	USER 32	USER 33	USER 34	USER 35	USER 36	USER 37	USER 38	USER 39	USER 40	USER 41	USER 42	USER 43	USER 44	USER 45	USER 46	USER 47	USER 48	USER 49	USER 50
AL1	AL2	AL3	AL4	AL5	AL6	AL7	AL8	AL9	AL10	AL11	AL12	AL13	AL14	AL15	AL16	AL17	AL18	AL19	AL20	AL21	AL22	AL23	AL24	AL25	AL26	AL27	AL28	AL29	AL30	AL31	AL32	AL33	AL34	AL35	AL36	AL37	AL38	AL39	AL40	AL41	AL42	AL43	AL44	AL45	AL46	AL47	AL48	AL49	AL50

TB2 and TB3 are optional and/or project dependent

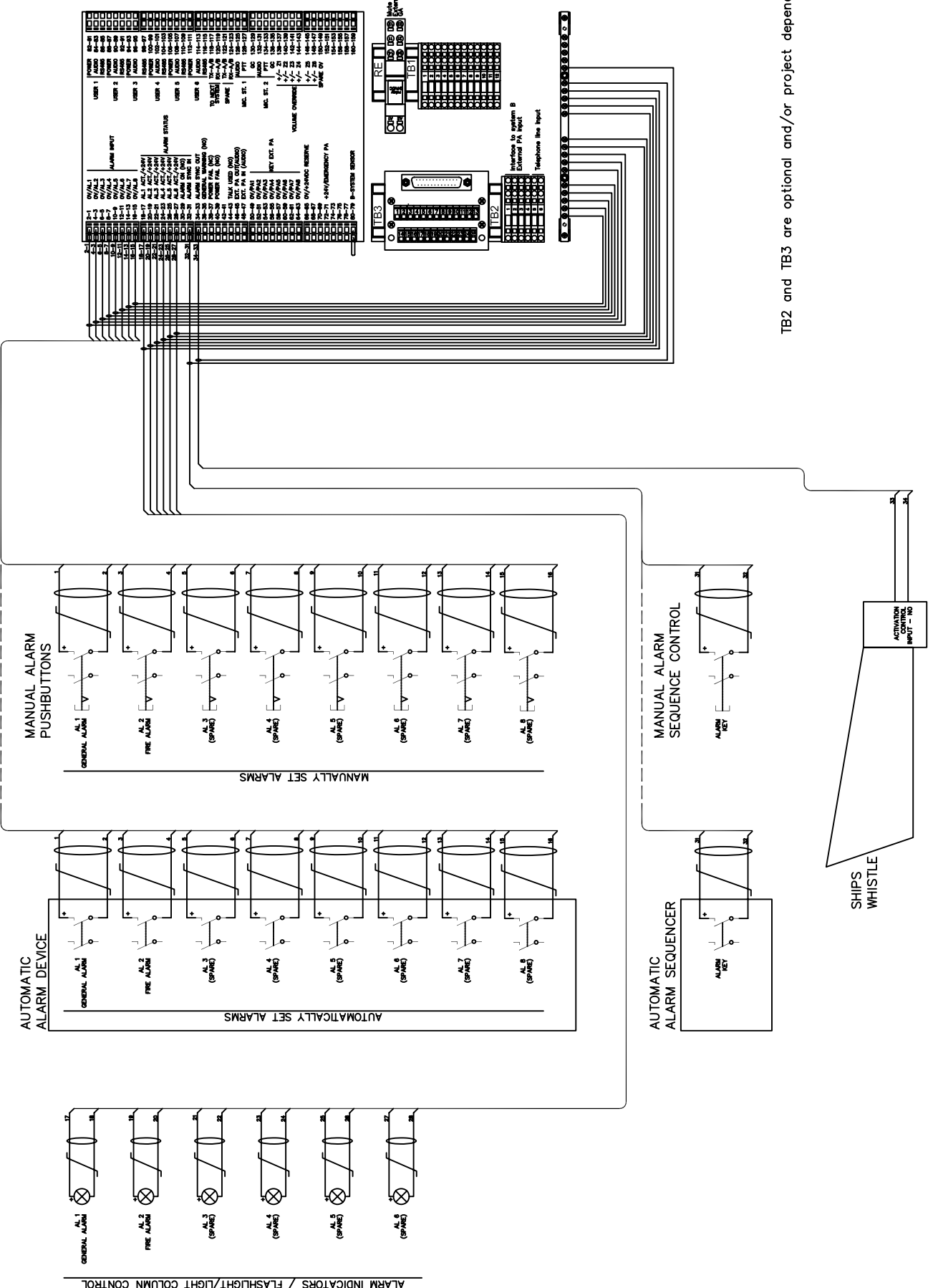

TB2 and TB3 are optional and/or project dependent

A B C D E F 1 2 3 4 5 6 7 8

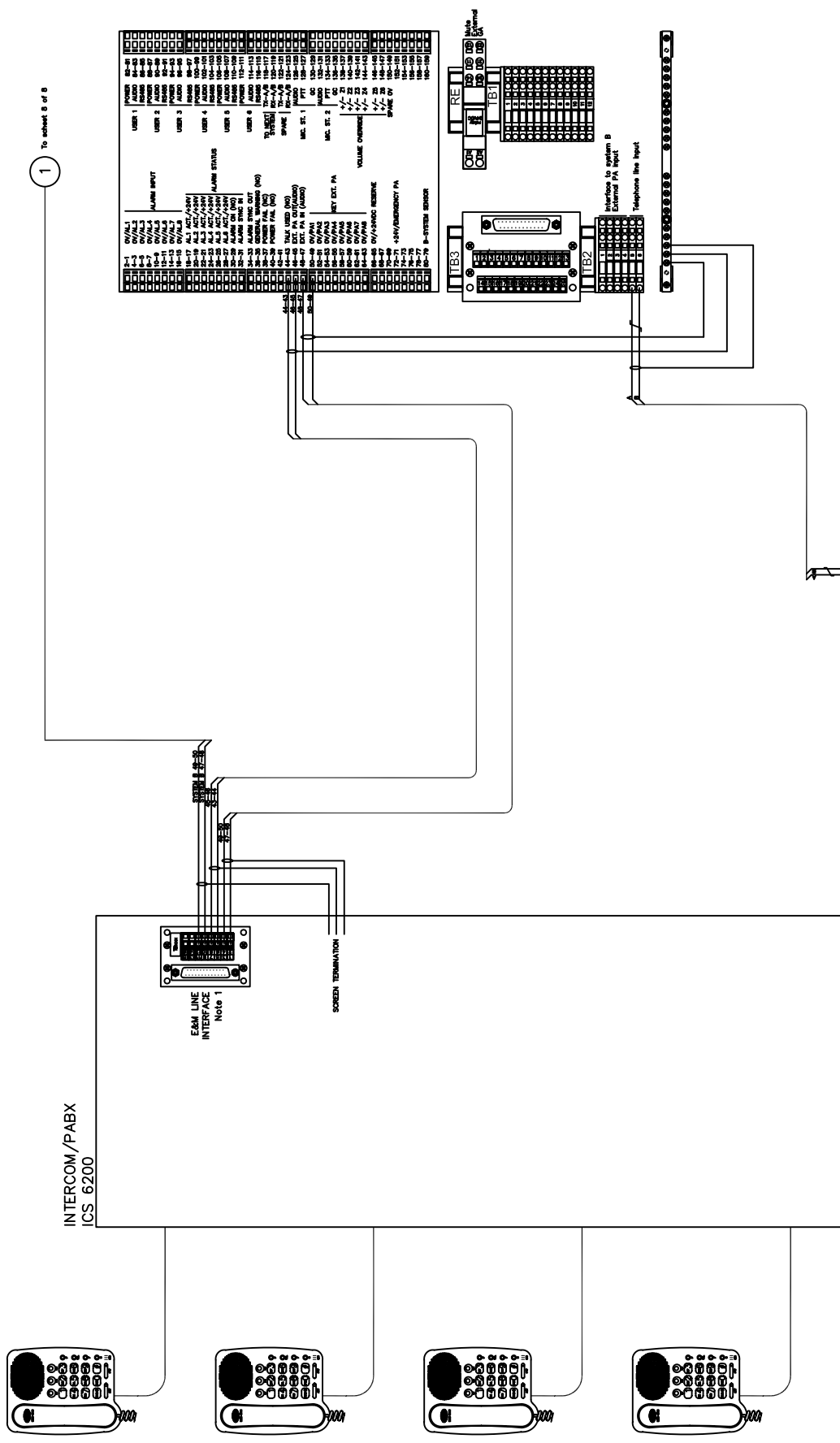

1 To sheet 8 of 8

TB2 and TB3 are optional and/or project dependent

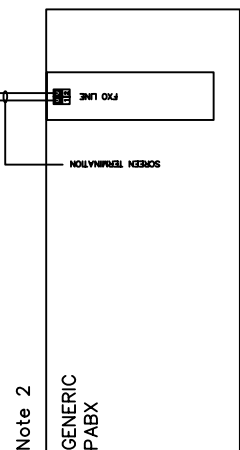

NOTE 1:
The interface and functionality of connection between the ICS 6200 and the MPA 1600 is subject to custom configuration of both the ICS 6200 and the MPA 1600 regarding both hardware and software.

NOTE 2:
Using both the ICS 6200 and a generic PABX at the same time is not normally recommended and will require some special considerations.

A B C D E F 1 2 3 4 5 6 7 8

System "A"

System "B"

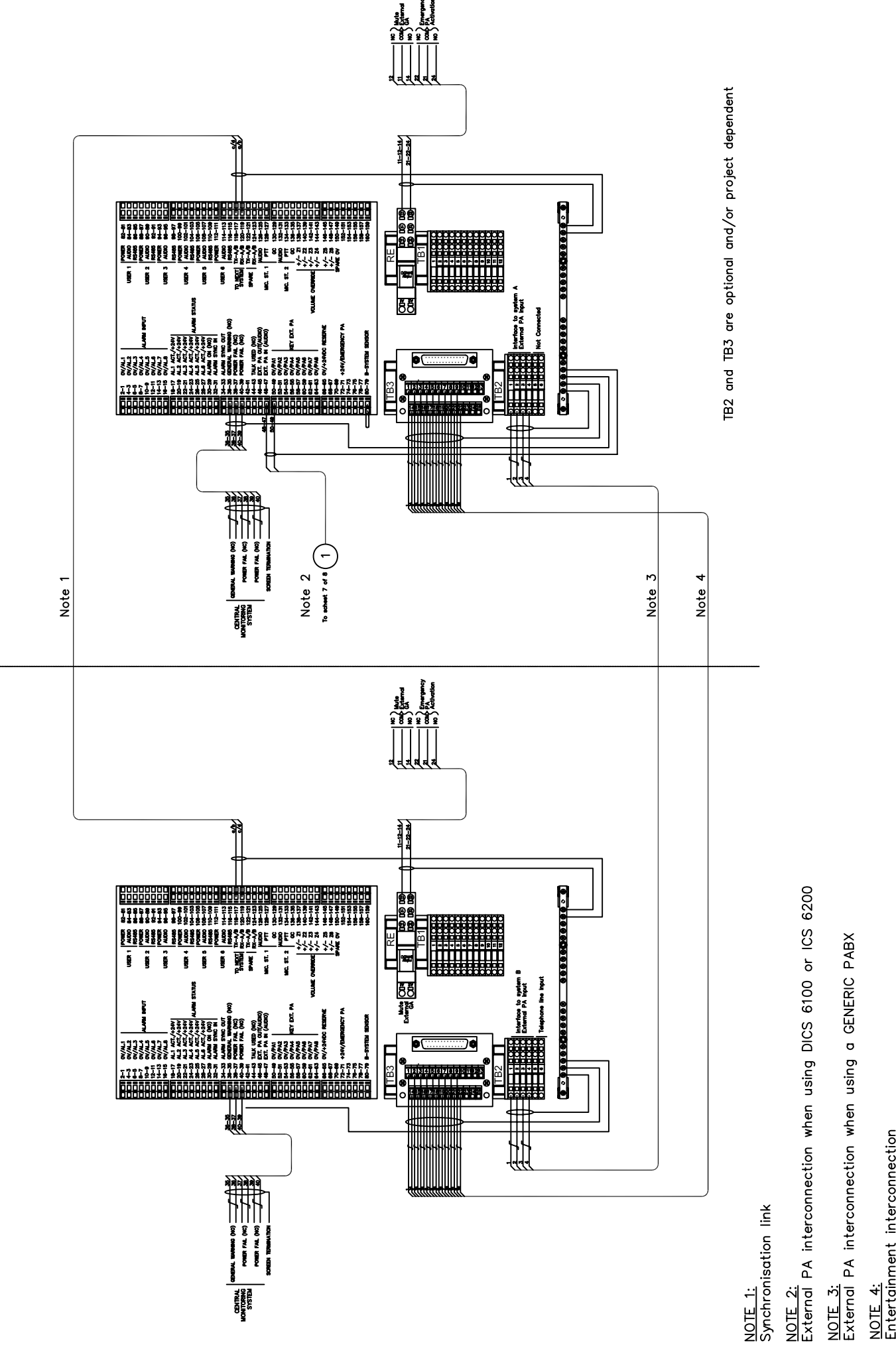

Note 1

Note 2
To sheet 7 of 8

Note 3

Note 4

TB2 and TB3 are optional and/or project dependent

- NOTE 1:
Synchronisation link
- NOTE 2:
External PA interconnection when using DICS 6100 or ICS 6200
- NOTE 3:
External PA interconnection when using a GENERIC PABX
- NOTE 4:
Entertainment interconnection

LIST OF CONTENT		Page
1	SCOPE	2
2	TERMINOLOGY	2
	2.1 Abbreviations	2
3	REFERENCE DOCUMENTS	2
4	INTRODUCTION	3
5	BRIEF SYSTEM DESCRIPTION	3
	5.1 General	3
	5.2 Central equipment	3
	5.3 Access & Control panels	3
6	TEST PLAN.....	4
	6.1 Test philosophy	4
	6.2 Scope of test	4
7	SPECIFIC TEST PROCEDURE	4
	7.1 General checks.....	4
	7.2 Workmanship	5
8	FUNCTIONAL TESTING OF UNITS	5
	8.1 MPA 1600 Operation unit	5
	8.2 MPA 1601 Access units	5
	8.2.1 Normal PAGING.....	5
	8.2.2 EMergency PAGING	5
	8.2.3 Indicators	5
	8.2.4 Priority by normal paging "PA"	6
	8.2.5 External Control outputs	7
	8.3 Zones	7
	8.4 MPA 1603 Alarm Panel	7
	8.4.1 Alarm setting	7
	8.4.2 External Control outputs	8
	8.5 Paging during alarm (General Alarm)	8
	8.6 Failure / warning outputs.....	8
	8.7 Redundancy test.....	8
	8.8 Sound Pressure Level	8

9	TEST INSTRUMENTS	10
10	PARTICIPANTS	10
11	PUNCH LIST.....	11

1 SCOPE

This document is valid as commissioning procedure for the General Alarm / Public Address System MPA 1600.

2 TERMINOLOGY

2.1 Abbreviations

AGC	Automatic Gain Control
EM-PA	Emergency Paging
FAT	Factory Acceptance Test
GA	General Alarm
I.S.	Intrinsically safe
LED	Light emitting diode
NO	Normally Open
OK	Accepted
PA	Public Address / Paging
PABX	Telephone central
PA & GA	Public address and General
PTT	Alarm Push to talk
S/N	Signal/Noise ratio
SPL	Sound Pressure Level
THD	Total Harmonic Distortion
UHF	Ultra high frequency

3 REFERENCE DOCUMENTS

Doc. No.:	Name / Description	Type:
NS-EN ISO 9001:2000	QA MANAGEMENT SYSTEM CERTIFICATE	Certificate
DNV reports: 2007-3218 2007-3256	MPA 1600 – IEC 60945 CERTIFICATE	Certificate
03118-000-DE	MPA 1600 SYSTEM	Description
03118-000-IS	-- “ --	Installation Procedure
03118-000-OP	-- “ --	Operation Procedure
03118-100-BD	MPA 1600 SYSTEM. Type approval Requirements	Block Diagram

Doc.No.: 03118-100-CO

03118-025-EC	-- “ --	External Connection
03118-100-CO	-- “ --	Commissioning Procedure
03118-001-ML	MPA 1600 OPERATION UNIT	Mechanical Layout
03118-040-ML	MPA 1601, CONTROL UNIT, Ver. 05827	Mechanical Layout
03118-038-ML	MPA 1604, CONTROL UNIT, Ver. 05827	Mechanical Layout
03118-041-ML	MPA 1603, ALARM PANEL, Ver. 05827	Mechanical Layout
03118-101-ML	MPA 1600 SYSTEM, 15U WALL CABINET	Mechanical Layout
03118-102-ML	MPA 1600 SYSTEM, 42U EQUIPMENT RACK	Mechanical Layout
PA 6312/24/36	INTER-M POWER AMPLIFIER, 240/360W	Technical Specifications
PA 6312/24/36	INTER-M POWER AMPLIFIER, 240W	Operation Manual
03101-004-ML	AMPLIFIER 400W / 48V, 1670	Mechanical Layout
1670	AMPLIFIER 400W / 48V, 1670	Data Sheet

4 INTRODUCTION

The purpose of this document is to specify all testing/measurement to be carried out during the commissioning. Test results and identified problems will be recorded as a “Commissioning report.”

The purpose of the commissioning is to verify that the equipment fulfils all functional requirements as set forth in the specification provided by the client. Further, the test objective is to verify that cables, terminals and mechanical workmanship of the delivered equipment complies with project standard and overall industry standards for such equipment.

5 BRIEF SYSTEM DESCRIPTION**5.1 General**

The Public Address & Alarm system is designed, produced and delivered by Zenitel. The delivery comprises centralised equipment mounted in racks, as well as equipment for installation throughout the vessel / platform.

There are two main purposes for the PA system, one is to broadcast general announcements throughout the platform and the other is to distribute alarm tones and guide platform personnel during possible emergency situations.

5.2 Central equipment

The PA & GA system is a duplicated system each containing two equally equipped central wall cabinets / racks (customer dependant). Each containing the MPA 1600 Operation Unit, the required amount of PA6312, PA6324, PA6336 and/or 1670 power amplifiers and distribution and termination modules.

Outputs to field equipment are divided into separate A and B cable routing.

5.3 Access & Control panels

At least two Control Units, type MPA 1601, and two Alarm Panels, type MPA 1603 are required, but up to 6 of each type can be supplied. The Control Unit MPA 1604 can be used in positions not requiring access to the Emergency PA operation.

6 TEST PLAN

6.1 Test philosophy

An internal Pre-FAT testing of the Public Address System will be conducted at Zenitel's premises prior to the FAT. The Pre FAT test results will be available during FAT.

The client will thus have the option to select only a number of Access units and Amplifiers for verification, as testing of all interfaces is very time consuming.

All check/tests recorded shall end up in a status Pass or Fail. Any deviations or discrepancies shall be recorded in the FAT Report - Punch List.

6.2 Scope of test

The testing will demonstrate that the equipment has been built and configured to meet the functional requirements of the Specification, and in accordance with the provided documentation.

The tests will also show that the basic performance requirements (e.g. Signal Levels and functions) are met.

7 SPECIFIC TEST PROCEDURE

7.1 General checks

The Equipment check will be performed with reference to the Equipment List, and furthermore to be verified against "Mechanical layout (ML)" drawing.

Tag / Id. No.:	Test:	Result: Pass/Fail
	PA Control & amplifier cabinet / rack A	
	PA Control & amplifier cabinet / rack B	
	MPA 1601 - Navigation Bridge (User 1)	
	MPA 1603 - Navigation Bridge (User 1)	
	MPA 1601 - Alternative Position (User 2)	
	MPA 1603 - Alternative Position (User 2)	
	(Loudspeaker network is a separate issue)	

7.2 Workmanship

- a) Check terminal marking and compliance with drawings
- b) Check paint work and compliance with arrangement drawings
- c) Check cable termination for good workmanship

8 FUNCTIONAL TESTING OF UNITS

8.1 MPA 1600 Operation unit

PWR-LED: Green light indicates that power is present in the system.

PA-LED: Green light indicates that there is a PA-message in the system. Otherwise the led is dark.

AL-LED: Green light indicates that there is an Alarm in the system. Otherwise the led is dark.

ZONE-LED's: Green light in a LED indicates that there is activity in the defined zone.

USER-LED's: Green light in a LED indicates the active user in a system. A red light indicates an error in the corresponding user-panel.

RESET-switch: Pushing this switch will reset the MPA-system. The switch is protected from unintentional use, so a pencil-tip or similar must be used to activate it.

8.2 MPA 1601 Access units

8.2.1 Normal PAging

Paging may be performed in any combination of the six zones.

Zones are selected by the MPA 1601 zone-keys, and activated by the PA-key. These zones are not reset automatically after the message.

Default zone selection for the PA function is "All ex Cabins (Zone 1)"

The PA-key must be continuously pressed during messages. Pass/Fail

Check that each message is preceded by a chime attention signal (Ding-dong) Pass/Fail

8.2.2 EMergency PAging

Emergency paging is activated by keeping the EM-PA-key pressed down continuously for more than a second.

The EM-PA-key will automatically select all zones. Pass/Fail

Check that each message is preceded by a chime attention signal (Dooiing) Pass/Fail

8.2.3 Indicators

System status for A and B system is indicated on the user panel.

A green led indicates a healthy system.

A red led means there is a system failure Pass/Fail

Backlight and LED's are dimmed synchronously.

The intensity is adjusted in five steps, from low to high, by pushing the MPA 1601 DIM-key.

The DIM key will also dim the MPA 1603 alarm panel connected to the same user interface. Pass/Fail

Green LED's indicate selected, but idle zones.
Active zones that are selected will turn orange.
At the current active user-panel, the active zones are indicated by a green led. For all other users active zones are indicated by a red led. Pass/Fail

8.2.4 Priority by normal paging "PA"

The MPA system is a single access system. Meaning that only one operator can use the system at any time. The priority is programmable by software. If operator I has higher priority than operator II, then operator I can override operator II. However, the operator II can override I with the use of Emergency PA (EM-PA) key.

Priority is shown in the list below.
A "ding-dong" tone is generated for all new PA-messages.
The tone is also generated in override situations.

Priority levels:

- | | |
|---|------------|
| 1. MPA 1601 Navigation Bridge – Emergency PA | (User 1) |
| 2. MPA 1601 Alternative Position – Emergency PA | (User 2) |
| 3. Others – Emergency PA | (User 3-6) |
| 4. MPA 1601 Navigation Bridge – (normal) PA | (User 1) |
| 5. MPA 1601 Alternative Position –(normal) PA | (User 2) |
| 6. Others – (normal) PA | (User 3-6) |

Check by activating the EM-PA/PA-button that the priority of access between the users are according to the above table for any sequence and combination of users.
Users with the same priority level will operate as "first come, first serve." Pass/Fail

For the current active user-panel, the EM-PA/PA led is green.
For users with equal or lower priority than the current user, the led is red. And for users with higher priority the led is dark. Pass/Fail

When a user is paging (PA) in an override situation with differences between active and passive zones, then all zones will be active. Pass/Fail

If a user is shut down by an override situation the EM-PA/PA led will change from green to red on this user panel. Pass/Fail

8.2.5 External Control outputs

During paging (EM-PA/PA) some external outputs are activated.

- | | |
|-------------------------------|-----------|
| 1. Entertainment mute PA / GA | Pass/Fail |
| 2. Volume override | Pass/Fail |

Only during EM-PA:

- | | |
|-------------------------------------|-----------|
| 3. Mute of External GA during EM-PA | Pass/Fail |
|-------------------------------------|-----------|

8.3 Zones

Definitions of the different zones are site dependant, the list shown below is only an example (according to the external connection diagram 03118-100-BD / 03118-025-EC)

- Zone 1: Crew Accommodation
- Zone 2: Crew Areas
- Zone 3: Engine Areas
- Zone 4: Outdoor Areas
- Zone 5: Loudhailer
- Zone 6: Other

8.4 MPA 1603 Alarm Panel

8.4.1 Alarm setting

The MPA 1600 can handle 4 different alarm types. The General Alarm is mandatory, the others are optional and thus of lower priority and significance.

The alarms can be activated from the MPA 1603 alarm panel. All alarms will temporarily override any PA activity from any users. Users can regain access by reactivating EM-PA/PA.

Alarm priority:

1. General alarm (All zones)
2. Alarm 2 (configurable / optional)
3. Alarm 3 (configurable / optional)
4. Alarm 4 (configurable / optional)

Check that pressing the “Alarm 1” General Alarm key on the MPA 1603 alarm panel will cause a “Muster alarm” alarm tone in all areas regardless of any zone previous selection.

"All" zones are selected automatically.

Pass/Fail

8.4.2 External Control outputs

During General Alarm (EM-PA/PA) some external outputs are activated.

- | | |
|---------------------------------|-----------|
| 1. Entertainment mute PA / GA | Pass/Fail |
| 2. Volume override | Pass/Fail |
| 3. GA warning (flashing) lights | Pass/Fail |

The GA Alarm tone consist of 7 short, 1 long tone bursts. One output is provided for tone synchronisation and will be turned off (NO) and on (closing) along with the signal tone:

- | | |
|--|-----------|
| 4. GA interface to ships whistle / siren | Pass/Fail |
|--|-----------|

8.5 Paging during alarm (General Alarm)

Activating "PA" during alarm will automatically select the "EM-PA" functionality.

The alarm tone will be muted during this override.

Check this function. Pass/Fail

8.6 Failure / warning outputs

There are two dry closing contacts voltage for indication of failure and warning conditions:

- | | |
|--|-----------|
| 1. Power failure | |
| ➤ Primary and Secondary mains power supply missing | |
| ➤ Backup power missing | |
| | Pass/Fail |

- | | |
|------------------------------------|-----------|
| 2. General warning | |
| ➤ No communication with user panel | |
| | Pass/Fail |

8.7 Redundancy test

Remove power from "A" system. Ensure all alarms and paging operates satisfactorily on the "B" system. Restore power on "A" system.

Pass/Fail

Remove power from "B" system. Ensure all alarms and paging operates satisfactorily on the "A" system. Restore power on "B" system.

Pass/Fail

8.8 Sound Pressure Level

The major requirement of a GA / PA system is sufficient coverage and sound pressure level (SPL) for alarms and PA messages to be heard throughout the installation. The requirement is a minimum of 75dBA and at least 10dBA above the ambient noise level. The requirement is 80dBA and at least 10dBA above the ambient noise level in interior and exterior spaces.

9 TEST INSTRUMENTS

Required Test instruments:

Type	Manufacturer	Cal. date	Cal. due	Serial no

10 PARTICIPANTS

Date: _____

Company	Name	Sign.

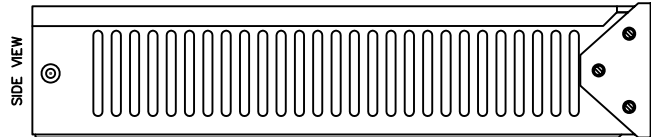
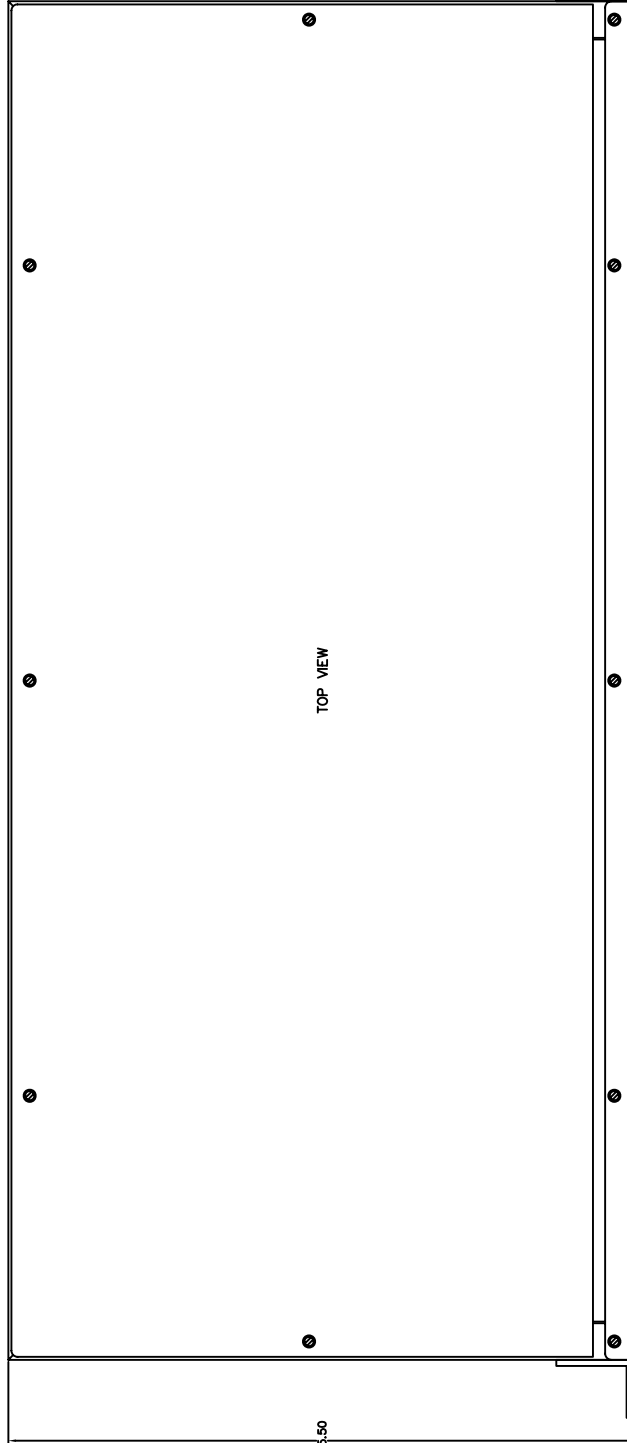
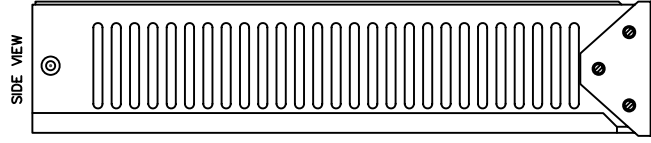
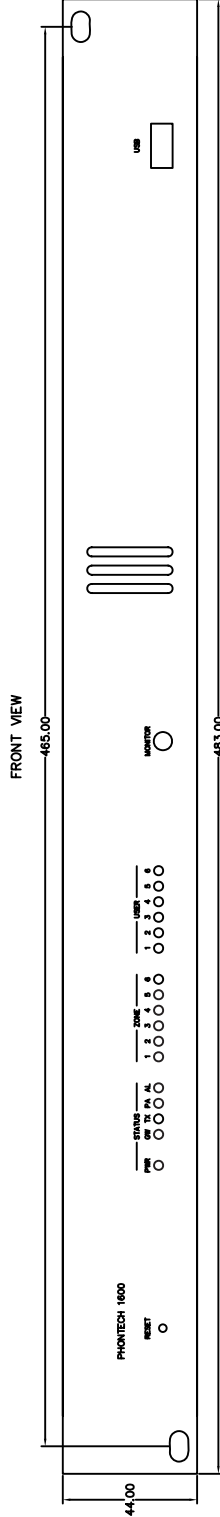
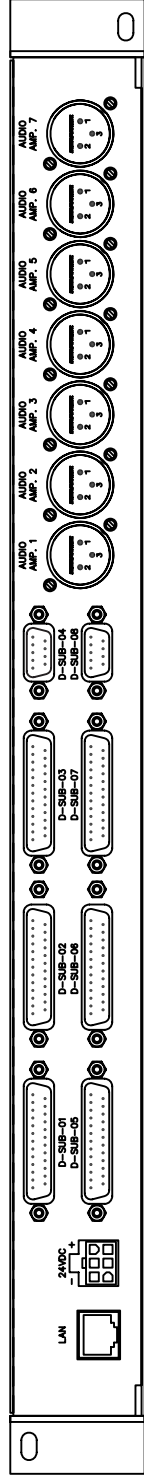

EQUIPMENT DATA:

MANUFACTURER	: PHONTECH AS.	FIXING DETAILS	: 4pcs. M5 BOLT.
MODEL / TYPE	: PHONTECH AS.	CABLE ENTRY	: REAR.
RACK / BOX TYPE	: 19" 1HE.	GLAND TYPE	: NA.
MATERIAL	: ALUZINK.	PROTECTION IP	: IP-20.
COLOUR	: RAL 9005/NATUR.	POWER SUPPLY	: 24VDC.
WEIGHT	: 3.00KG.	POWER CONSUMP.	: 350mA, MAX 5 Amp.
MOUNTING	: TO RACK/CONSOLE.	HEAT DISSIPATION	: 8 Watt.

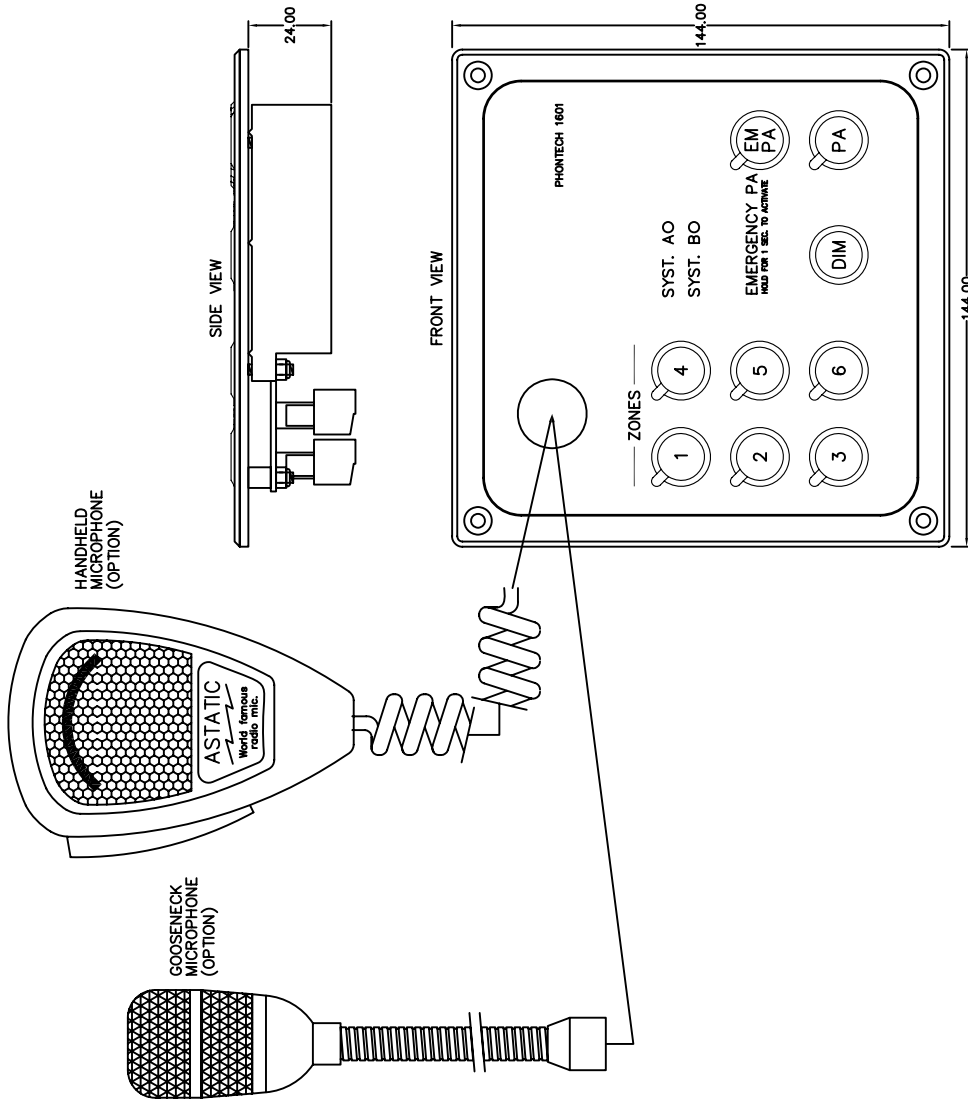

CUT-OUT AND MOUNTING DIMENSIONS.
REAR VIEW OF UNIT

EQUIPMENT DATA.

MANUFACTURER	: PHONTECH AS.	FIXING DETAILS	: 4pcs. M4 BOLTS.
MODEL/TYPE	: CONTROL UNIT.	ACCESS	: REAR.
RACK/BOX SUPPL.	: PHONTECH AS.	CABLE ENTRY	: REAR.
RACK/BOX TYPE	: 19" RACK MOUNT	PROTECTION	: IP-44
MATERIAL	: ALUMINIUM/STEEL	PROTECTION IP	: FROM CENTRAL.
COLOUR	: RAL 9005/NA TUR.	POWER SUPPLY	: FROM CENTRAL.
WEIGHT	: 0.80kg.	POWER CONSUMP.	: NA.
COLOUR	: NA.	HEAT DISSIPATION	: NA.
WEIGHT OG UNIT	: TO CONSOLE.		
MOUNTING	: TO CONSOLE.		

4

3

2

4

3

2

1

TERMINAL BLOCK DESCRIPTION:

SYSTEM A, P1

SYSTEM B, P2

1	LOCAL LS IN	15
2		16
3	SCREEN	17
4	LOCAL LS OUT	18
5	(MUTED)	19
6	SCREEN	20
7	AUDIO	21
8		22
9	SCREEN	23
10	RX	24
11	TX	25
12	SCREEN	26
13	+24VDC	27
14	0V (-)	28

MUTE RELAY FOR CONNECTION
OF LOCAL LOUDSPEAKER
(100 V LINE)

CONNECTION TO MPA
CENTRAL EQPT. / CABINET
TERMINAL BOARD
03118-011
SEE DOCUMENT 03118-000-EC

P3

1	MICROPHONE
2	
3	SCREEN
4	
5	PTT

MPA 1601 Ver. 05827, REAR VIEW

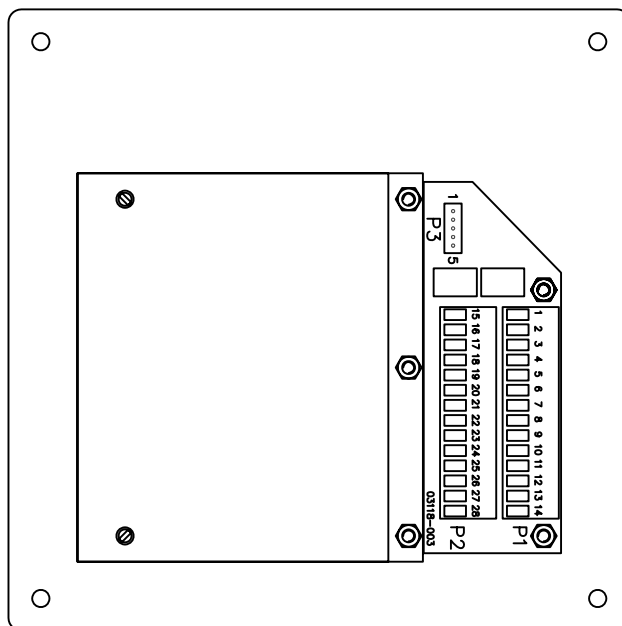

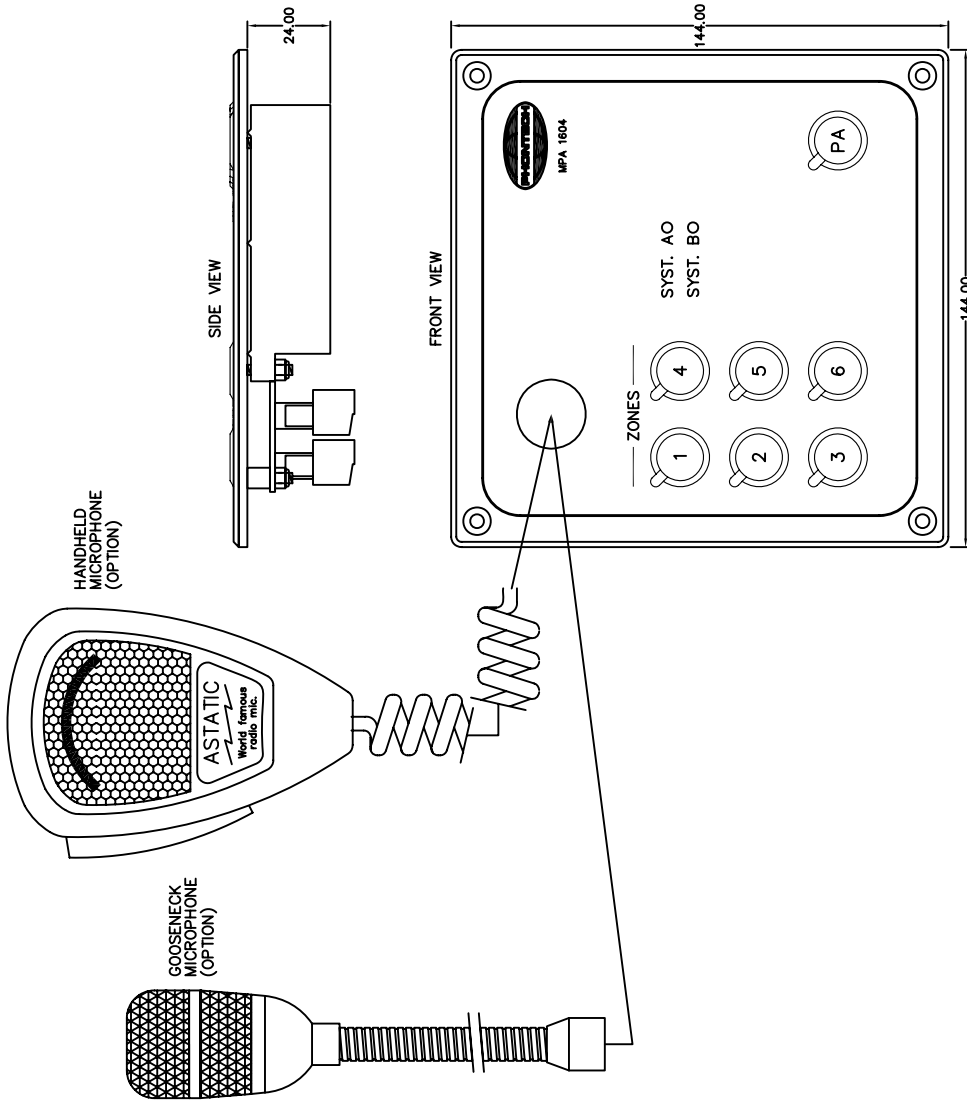

EQUIPMENT DATA:

MANUFACTURER	: PHONTECH AS.	FIXING DETAILS	: 4pcs. M4 BOLTS.
MODEL / TYPE	: CONTROL UNIT.	ACCESS	: REAR.
RACK / BOX SUPPL.	: PHONTECH AS.	CABLE ENTRY	: REAR.
FINISH	: ALUMINUM	PROTECTION	: IP-44
MATERIAL	: ALUMINIUM/STEEL	PROTECTION IP	: IP-44
COLOR	: RAL 9005/NATUR.	POWER SUPPLY	: FROM CENTRAL.
WEIGHT OG UNIT	: 0.60KG.	POWER CONSUMP.	: NA.
MOUNTING	: TO CONSOLE.	HEAT DISSIPATION	: NA.

1

2

3

4

A

TERMINAL BLOCK DESCRIPTION:

A

SYSTEM A, P1

SYSTEM B, P2

1	LOCAL LS IN	15
2		16
3	SCREEN	17
4	LOCAL LS OUT	18
5	(MUTED)	19
6	SCREEN	20
7	AUDIO	21
8		22
9	SCREEN	23
10	RX	24
11	TX	25
12	SCREEN	26
13	+24VDC	27
14	0V (-)	28

MUTE RELAY FOR CONNECTION
OF LOCAL LOUDSPEAKER
(100 V LINE)

CONNECTION TO MPA
CENTRAL EQPT. / CABINET
TERMINAL BOARD
03118-011
SEE DOCUMENT 03118-000-EC

B

B

C

C

MPA 1604, REAR VIEW

P3

1	MICROPHONE
2	
3	SCREEN
4	
5	PTT

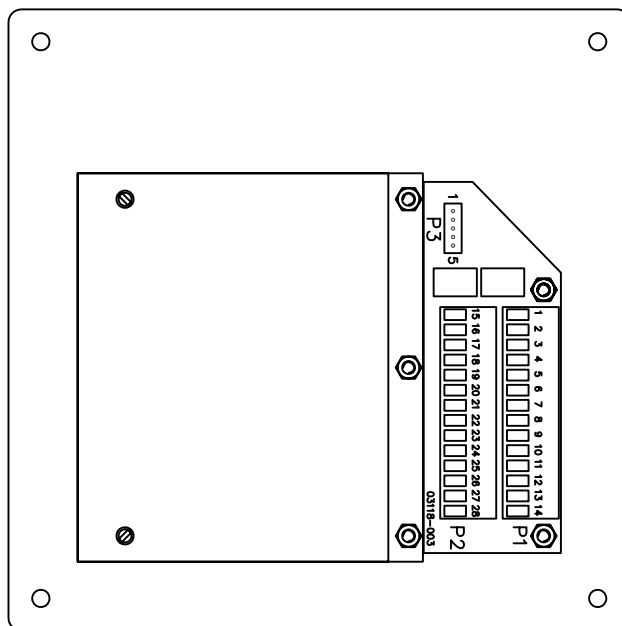

D

D

E

E

F

F

1

2

3

4

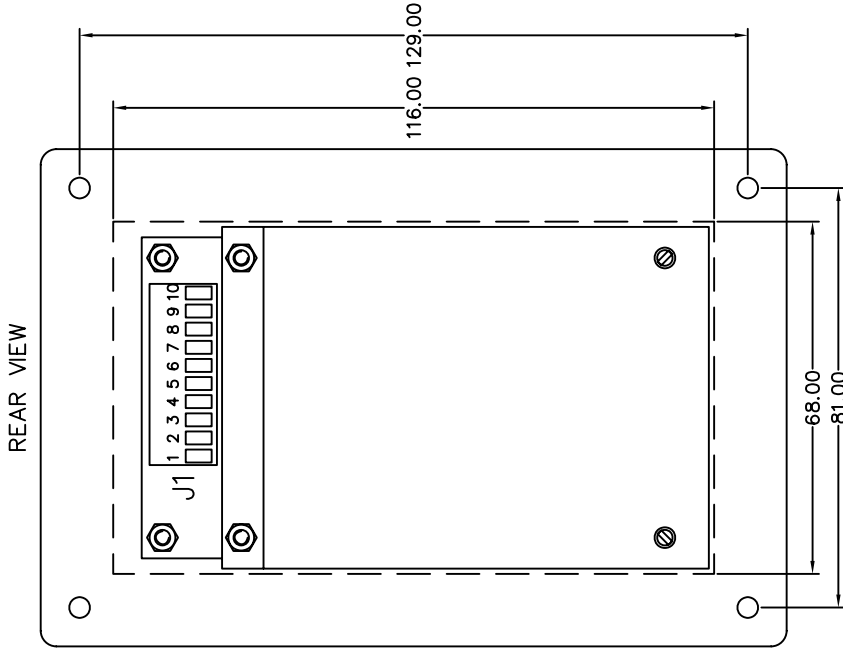
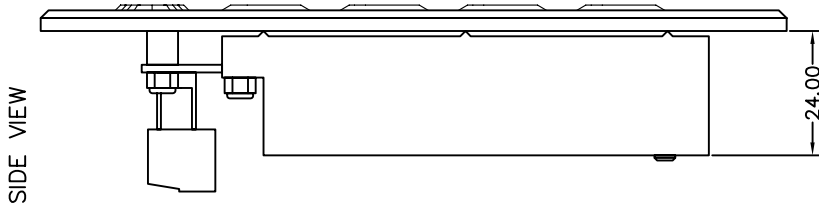
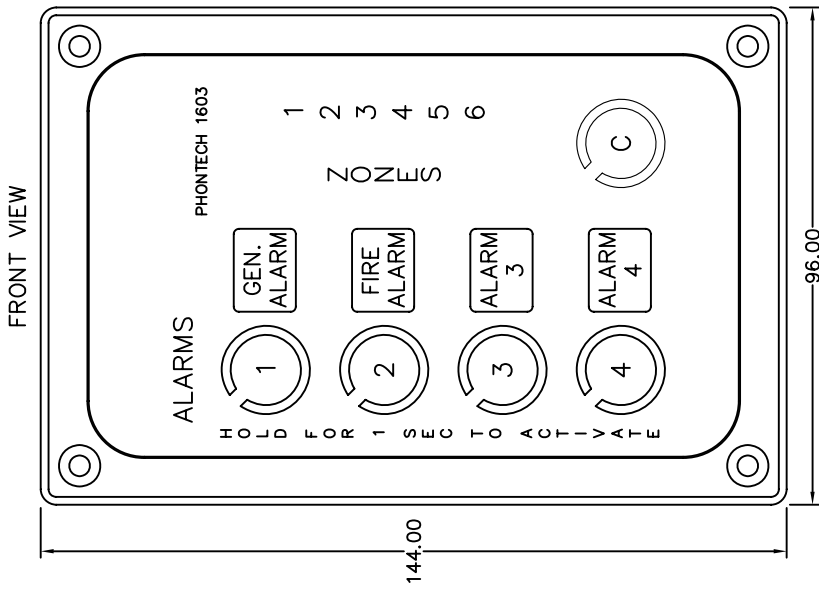

CUT-OUT AND MOUNTING DIMENSIONS.

EQUIPMENT DATA:

MANUFACTURER	: PHONTECH AS.	FIXING DETAILS	: 4pcs. M4 BOLTS.
MODEL/TYPE	: ALARM UNIT.	ACCESS	: REAR.
RACK/BOX SUPPL.	: PHONTECH AS.	CABLE ENTRY	: REAR.
RACK/BOX TYPE	: FOR CONSOLE.	GLAND TYPE	: NA.
MATERIAL	: ALUMINIUM/STEEL.	PROTECTION IP	: IP-44.
COLOUR	: RAL 9005/NATUR.	POWER SUPPLY	: FROM CENTRAL.
WEIGHT OG UNIT	: 0.50KG.	POWER CONSUMP.	: NA.
MOUNTING	: TO CONSOLE.	HEAT DISSIPATION	: NA.

1

2

3

4

A

A

TERMINAL BLOCK
DESCRIPTION:

A-SYSTEM

RX
TX
SCREEN

J1

1
2
3
4
5
6
7
8
9
10

RX
TX
SCREEN

B-SYSTEM

A-SYSTEM

+24VDC
0V (-)

+24VDC
0V (-)

B-SYSTEM

B

B

CONNECTION TO MPA
CENTRAL EQPT. / CABINET
TERMINAL BOARD
03118-011
SEE DOCUMENT 03118-000-EC

C

C

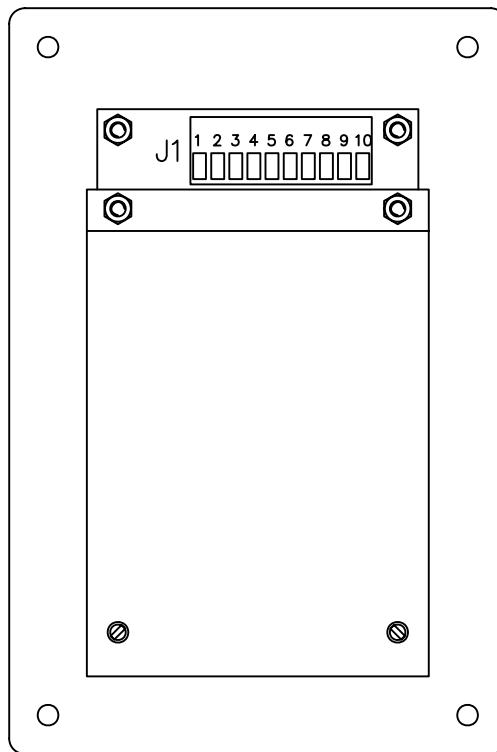

D

D

E

E

MPA 1603 Ver 05827, REAR VIEW

F

F

1

2

3

4

1

2

3

4

A

A

B

B

C

C

D

D

E

E

F

F

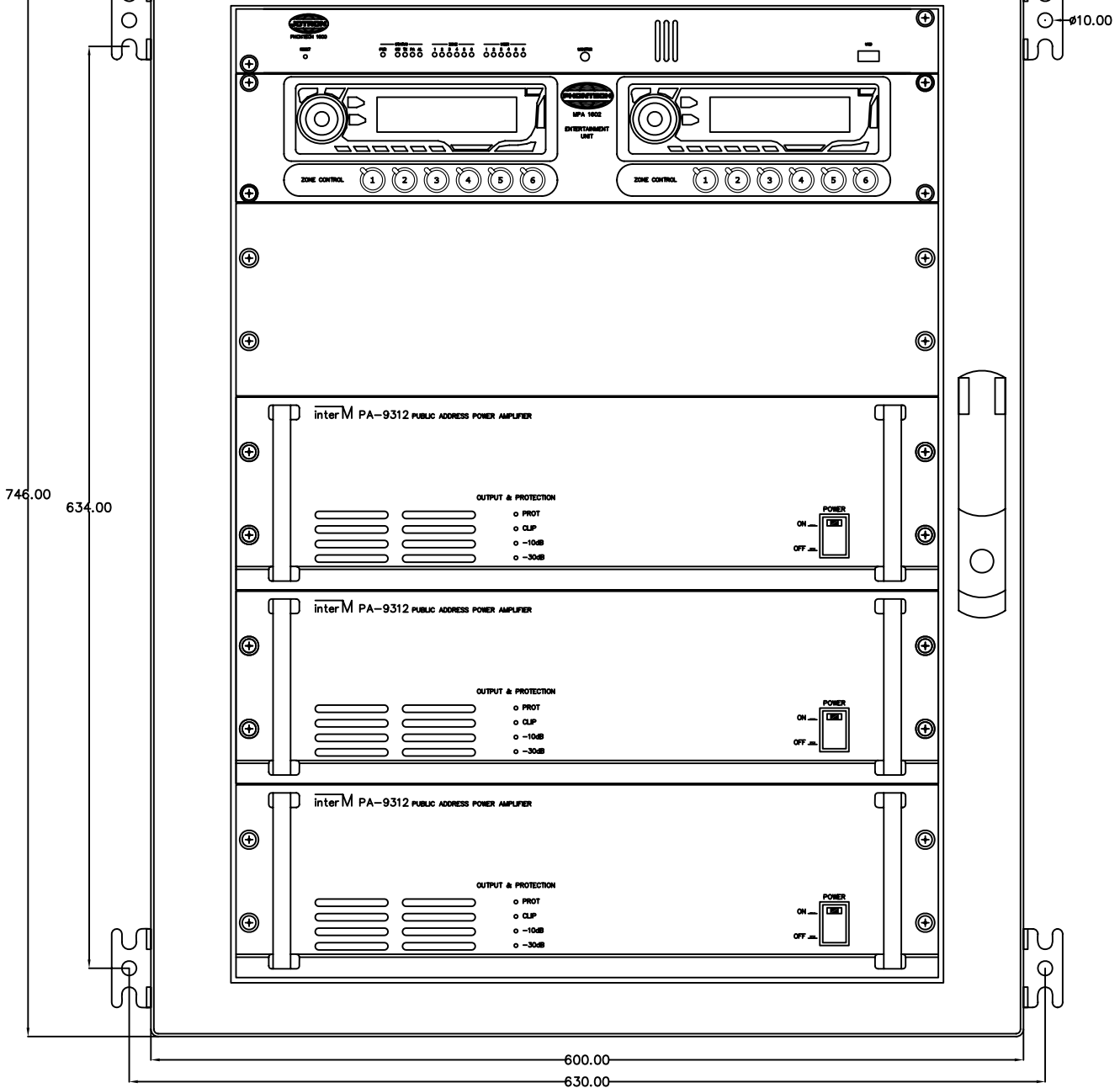

Note:
-Depth off cabinet: 573,00mm.

EQUIPMENT DATA:

MANUFACTURER	: Zenitel AS	FIXING DETAILS	: 4pcs. M8 Bolt.
MODEL/TYPE	: Public Address System.	ACCESS	: Wall Unit.
RACK/BOX SUPPL.	: Rittal.	CABLE ENTRY	: Bottom of Wall Unit.
RACK/BOX TYPE	: DK-7715.135.	GLAND TYPE	: NA.
MATERIAL	: Steel.	PROTECTION IP	: IP-22.
COLOUR	: RAL 7035/7015.	POWER SUPPLY	: 220VAC/24VDC.
WEIGHT OF UNIT	: Basic: 40Kg./Max: 70Kg.	POW. CONS. Idle	: System Dependency.
MOUNTING	: To Wall.	POW. CONS. Max	: System Dependency.
		HEAT DISSIPATION	: System Dependency.

MODEL NO: PA-6312/6324/6336/6348

TITLE: 120, 240, 360 and 480 watts Commercial PA amplifiers

OVERVIEW

PA-6312/6324/6336/6348 are Inter-M's best-selling commercial PA amplifiers. They are recognized for their ruggedness, reliability and performance. They are the installer's choice for sound reinforcement, background music, paging, and public address systems. Featuring low-distortion, low-noise amplifier electronics circuits which provides a high-output and a high S / N ratio. PA 6300 series amps provide a wide dynamic range with excellent headroom. An onboard High Pass Filter protects both amplifier and speakers from damaging transients. A comprehensive thermal/electrical protection circuit ensures long-haul dependability. Thermister protected output helps ensure overall stability and provides input overload protection. Internal airflow and exceptionally quiet multi-stage fans ensures amplifier cooling. Phoenix-style terminals provides for quick, easy hookup. Models are available in a variety of output power, 120, 240, 360 and 480 watts power output in 8/4 ohm low impedance and in 70/100V high impedances output using low-distortion transformers. The PA 6300 series offers outstanding versatility, long term reliability, and a remarkable value for any installation application.

FEATURE

High power - low noise circuit

Low-noise, high-output circuit offers better than 95dB signal-to-noise ratio.
120W RMS (PA-6312), 240W RMS (PA-6324), 360W RMS (PA-6336), 480W RMS (PA-6348) output power
THD (Total Harmonic Distortion) is less than 1%

400Hz HPF (High Pass Filter)

400Hz, High Pass Filter removes low frequency noise, improves speech intelligibility and protects both amplifier and speakers from damaging transients.

-12dB gain adjustment

Rear mounted trim pot offers -12dB volume adjustment the nominal output.
(Variable output voltage of up to 75%)

Output level indicators

Front panel LED indicates visual changes in output level.

Rack Mountable

Can be rack mounted utilizes 3U of rack mount space or used in a Table Top configuration.

High reliability

Build from high-reliability components ensures ruggedness and long term failure free use.

Thermal Protection

Thermal and overload protection including controlled airflow and variable speed cooling ensures long-haul dependability

APPLICATION

The PA-63000 Series amplifiers are high power output high quality rugged and reliable amplifiers to design to be used with the 6000 series mass communication system. Because of their outstanding versatility they have been the installer's choice for sound reinforcement, background music, paging, and public address systems.

FRONT PANEL

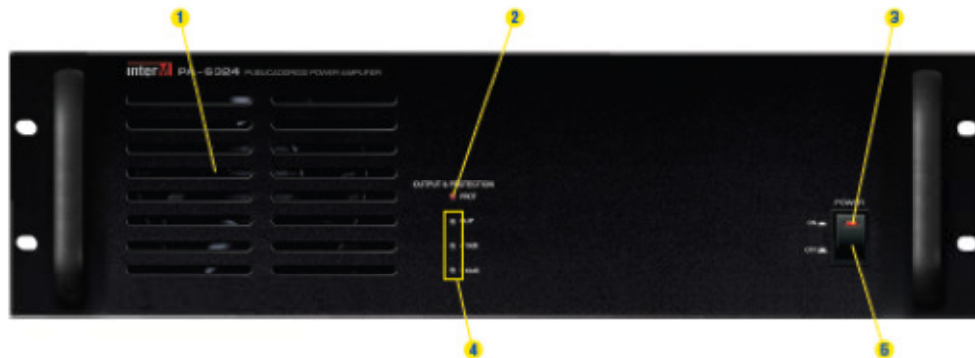

(1) FAN

Airflow intake multi-stage quiet fans ensures amplifier cooling.

(2) PROT (protection circuit indicators)

LED indicator displays if the amplifier protection mode.

(3) POWER LED

LED indicates power ON / OFF status five times as this unit is lit if the power switch ON and work instructions.

(4) OUTPUT LEVEL INDICATOR

LED indicates output power level.

(5) POWER SWITCH

An LED indicator confirms power on status of the amplifier.

REAR PANEL

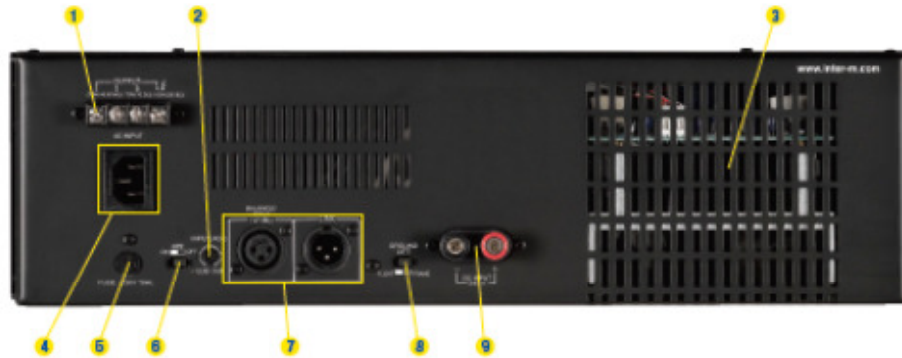

(1) OUTPUT TERMINAL

Allows selection of low impedance, 70.7 or 100 volt high impedance output.

(2) LEVEL ADJUST VOLUME

Rear mounted trim pot offers -12dB volume adjustment the nominal output. (Variable output voltage of up to 75%)

(3) VENTELATION

Ventilation out-take

(4) AC POWER INPUT

117VAC/60HZ 220 VAC50HZ

(5) FUSE

(6) LPF Switch

400Hz, High Pass Filter On/off switch

(7) Signal input terminal

Phoenix-style terminals

(8) Ground Lift Switch

(9) 24V DC back up power

Related Products

- ECS-6216P
- ECS-6216S
- PX-6216
- ECS-6216MS
- RME-6108
- DIB-6000

Operation Manual

Public Address Power Amplifier
PA-6312/6324/6336/6348



* Rack mount products in the Western Hemisphere(North America, South America, and the Caribbean) do not have handles installed due to customer preference.

interM

Welcome

A personal welcome to you from the management and employees of Inter-M

All of the co-workers here at Inter-M are dedicated to providing excellent products with inherently good value, and we are delighted you have purchased one of our products.

We sincerely trust this product will provide years of satisfactory service, but if anything is not to your complete satisfaction, we will endeavor to make things right.

Welcome to Inter-M, and thank you for becoming part of our worldwide extended family!



This symbol is intended to alert the user to the presence of uninsulated "dangerous voltage" within the product's enclosure that may be of sufficient magnitude to constitute a risk of electric shock to persons.



This symbol is intended to alert the user to the presence of important operation and maintenance (servicing) instructions in the literature accompanying the appliance.

Caution: To prevent electric shock do not use this (polarized) plug with an extension cord, receptacle or other outlet unless the blades can be fully inserted to prevent blade exposure.

Attentions: Pour prévenir les chocs électriques ne pas utiliser cette fiche polarisée avec un prolongateur, une prise de courant ou une autre sortie de courant, sauf si les lames peuvent être insérées à fond sans en laisser aucune partie à découvert.

WARNING

To prevent fire or shock hazard, do not expose the unit to rain or moisture.

*WARNING FOR YOUR PROTECTION PLEASE READ THE FOLLOWING-WATER AND MOISTURE: Unit should not be used near water(e.g. near a bathtub, washbowl, kitchen sink, laundry tub, in a wet basement, or near a swimming pool, etc). Care should be taken so than objects do not fall and liquids are not spilled into the enclosure through openings.

*CLASS 2 WIRING (Adjacent to speaker terminal): The speaker output of this apparatus can exceed 10 Watts and could be a shock injury. Connection to speakers should be performed by a skilled person.

*Do not install this equipment in a confined space such as a book case or similar unit.

*This apparatus shall not be exposed to dripping or splashing and no objects filled with liquids, such vases, shall be placed on the apparatus.

*This apparatus shall be connected to a mains socket outlet with a protective earthing connection.

*It has heed to be easy to disconnect the device. To disconnect the device from power, separate AC input cable from inlet or unplug the AC Cord.

*The socket-outlet shall be installed near the equipment and shall be easily accessible.

CAUTION

*These servicing instructions are for use by qualified service personnel only. To reduce the risk of electric shock, do not perform any servicing other than that contained in the operating instructions unless you are qualified to do so.

NOTE

*This equipment has been tested and found to comply with the limits for a Class A digital device, pursuant to Part 15 of the FCC Rules. These limits are designed to provide reasonable protection against harmful interference when the equipment is operated in a commercial environment. This equipment generates, uses, and can radiate radio frequency energy and, if not installed and used in accordance with the instruction manual, may cause harmful interference to radio communications. Operation of this equipment in a residential area is likely to cause harmful interference in which case the user will be required to correct the interference at his own expense.

Contents

- Unpacking** 2
- Installation**
 - Environment..... 2
 - Important Safety Instructions..... 2
- Features**..... 3
 - Accessories..... 3
- Operation** 3
- Front Panel** 4
- Rear Panel** 6
- Connecting Speakers** 7
- Applications** 8
- Block Diagram** 9
- Specifications** 10
- Service**
 - Procedures..... 12
 - Schematic..... 12
 - Parts List 12
- Variations and Options** 12
- Warranty** 12

Unpacking

Although your PA-6312/6324/6336/6348 is neither complicated nor difficult to operate, we recommend you take a few minutes to read this brief manual and familiarize yourself with the important information regarding product features, setup and operation.

As with most electronic devices, we strongly recommend you to retain the original packaging. In the unlikely event the product must be returned for servicing, the original packaging (or reasonable equivalent) is required.

Installation

Environment

Never place this product in an environment which could alter its performance or reduce its service life. Such environments usually include high levels of heat, dust, moisture, and vibration.

IMPORTANT SAFETY INSTRUCTIONS

1. Read these instructions.
2. Keep these instructions.
3. Heed all warnings.
4. Follow all instructions.
5. Do not use this apparatus near water.
6. Clean only with dry cloth.
7. Do not block any ventilation openings. Install in accordance with the manufacturer's instructions.
8. Do not install near any heat sources such as radiators, heat registers, stoves, or other apparatus (including amplifiers) that produce heat.
9. Do not defeat the safety purpose of the polarized or grounding-type plug. A polarized plug has two blades with one wider than the other. A grounding type plug has two blades and a third grounding prong. The wide blade or the third prong are provided for your safety. If the provided plug does not fit into your outlet, consult an electrician for replacement of the obsolete outlet.
10. Protect the power cord from being walked on or pinched particularly at plugs, convenience receptacles, and the point where they exit from the apparatus.
11. Only use attachments/accessories specified by the manufacturer.
12. Use only with the cart, stand, tripod, bracket, or table specified by the manufacturer, or sold with the apparatus. When a cart is used, use caution when moving the cart/apparatus combination to avoid injury from tip-over.
13. Unplug this apparatus during lightning storms or when unused for long periods of time.
14. Refer all servicing to qualified service personnel. Servicing is required when the apparatus has been damaged in any way, such as power-supply cord or plug is damaged, liquid has been spilled or objects have fallen into the apparatus, the apparatus has been exposed to rain or moisture, does not operate normally, or has been dropped.



Features

- VARIETY OF POWER

- 120W (PA-6312), 240W (PA-6324) or 360W (PA-6336) of RMS power, with less than 1% THD.
- 480W(PA-6348) of RMS power, with less than 5% THD.

- BALANCED INPUT

Balanced XLR inputs to reduce ground hum and increase efficiency.

- GAIN ADJUSTMENT

Input gain is adjustable from -12dB to 0dB (1V) via rear panel control.

- EMERGENCY BATTERY BACKUP

Emergency battery backup for unexpected AC power failure.

- SLIM DESIGN, COMPACT SIZE

Streamlined design fits in a compact 3RU space.

Accessories

One detachable AC power cord and XLR cord are provided for use with this product.

Operation

Make certain that speakers and input sources are properly connected before switching on.
Keep volume levels turned down before switching on.

NOTE: The system's operation is delayed by approximately three seconds after pressing the power switch. This is due to the built-in protection circuitry, designed to protect speakers and other system components.

Front Panel

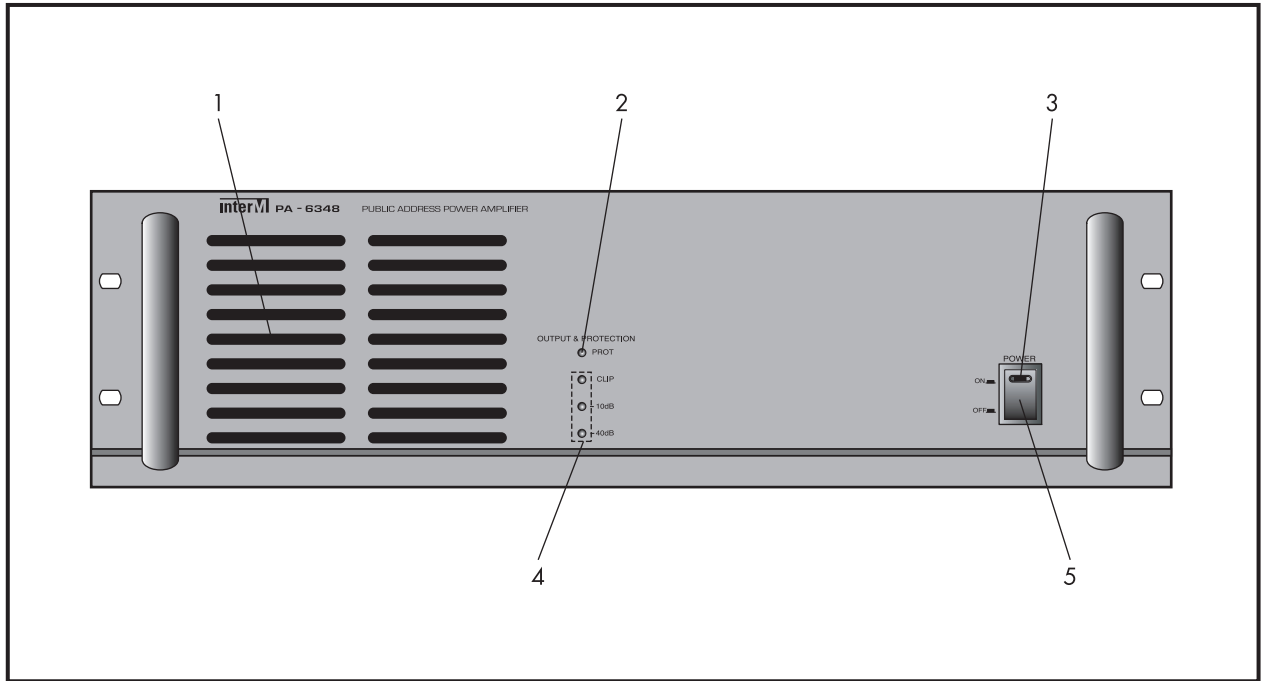

1. FAN VENTS

These vents provide cool air flow into the unit. It is important to keep them free of obstructions, to prevent the unit from overheating. It is also important to operate the unit in a dust-free environment.

2. PROTECTION INDICATOR

This LED indicates the state of the amplifier's protection circuitry. When the Protection LED is on (illuminated), the protection circuitry is active, indicating that the unit is not operating normally. This is typically due to overheating or power limiting. Please check the Input and Output condition of the amplifier.

3. POWER LED

When the unit is powered on, the Power LED will glow steadily.

4. OUTPUT LEVEL INDICATOR

These three LEDs indicate the amplifier's output status. The -40dB LED indicates the presence of audio signal at the amplifier's output. The -10dB LED indicates output at nominal operating range. The red CLIP LED indicates an excessive output level. Do not operate the unit with the CLIP LED continuously on (illuminated).

5. POWER SWITCH

Pressing this switch turns the unit on, as indicated by the Power LED. Pressing it again turns the unit off.

Rear Panel

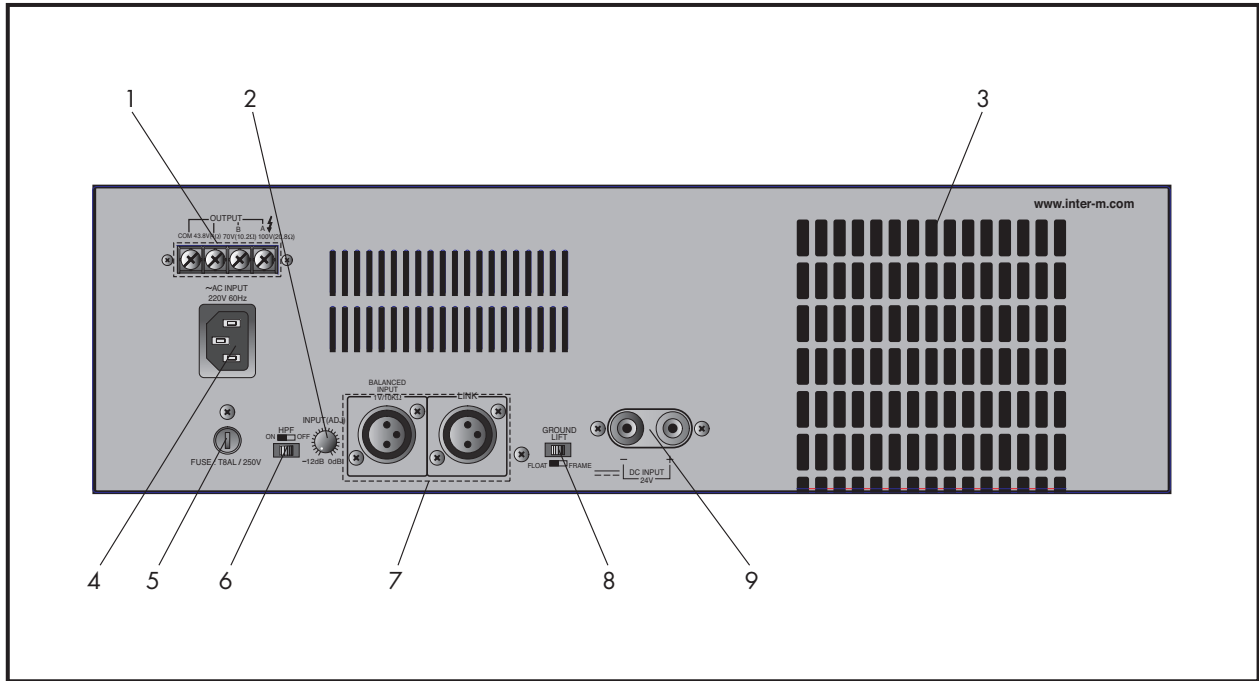

1. SPEAKER OUTPUT TERMINALS

These terminals are used to connect speakers to the unit. You may select either 4Ω or 8Ω conventional operation, or High Impedance operation at either 70V or 100V. Make certain the combined impedance of the speakers is equal to or higher than the rated load impedance of the amplifier. Refer to page 7 for minimum load impedance and output voltage.

2. LEVEL CONTROL

This knob provides continuous control of the amplifier's output level, from -12dB to 0dB (reference input of 0dB at 1V). Turning the knob clockwise increases the level, and turning it counter-clockwise decreases the level.

3. FAN VENTS

These vents provide hot air flow out of the unit. It is important to keep them free of obstructions, to prevent the unit from overheating. It is also important to operate the unit in a dust-free environment.

4. AC POWER INPUT

Connect the supplied standard AC input cable here.

5. FUSE HOLDER

This holder contains the AC overload protection fuse. If the fuse has blown out, replace it with a fuse of the same type and rating.

If the fuse continues to blow, refer servicing to a qualified service technician.

6. HIGH-PASS FILTER SWITCH

This switch activates the high-pass filter circuitry, which decreases frequencies lower than 400Hz by -3dB. The high-pass filter is designed to protect speakers from damage caused by excessive low frequency transients.

7. AUDIO INPUTS

These balanced XLR jacks are for the input of audio signal.

8. GROUND LIFT SWITCH

This switch provides for connection or disconnection of the amplifier's ground to AC "earth" ground, to prevent noise from ground loops. Under most circumstances, this switch should be set to FRAME position.

9. DC INPUT TERMINALS

These terminals are provided for the connection of backup battery. Connect a 24VDC(100A) battery source to these terminals. Make certain the red terminal is connected to the battery's positive (+) side, and the black terminal to the battery's negative (-) side.

Connecting Speakers

Before connecting speakers to your PA-6312/6324/6336/6348 unit, be sure to disconnect the AC power cable. Make certain that the total impedance is not less than the rated impedance indicated.

For 4Ω speakers, connect the positive (+) connector to the 4Ω terminal and the negative (-) connectors to the COM terminal.

For high-voltage distributed systems, connect with matching transformer to the COM and either B or A terminals. Be certain that the total impedance does not equal less than the rated impedance.

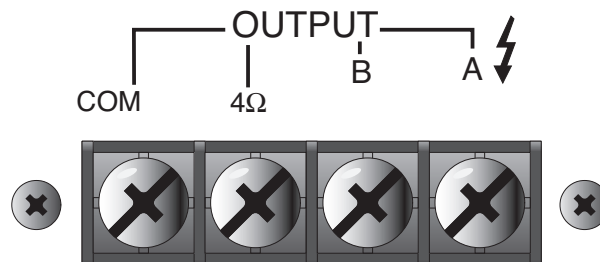

*The impedance and output voltage are as follows.

Countries	USA/CANADA & Associated Version			EC & Associated, JAPAN Version			
	Low	High (B)		High (A)	Low	High (B)	High (A)
Output Terminals	4Ω	8Ω	25V	70V	4Ω	70V	100V
PA-6312	22V	-	5.2Ω	41Ω	22V	41Ω	83Ω
PA-6324	31V	-	2.6Ω	21Ω	31V	21Ω	42Ω
PA-6336	38V	54V	-	13.6Ω	38V	13.6Ω	27.8Ω
PA-6348	43.8V	62V	-	10.2Ω	43.8V	10.2Ω	20.8Ω

Applications

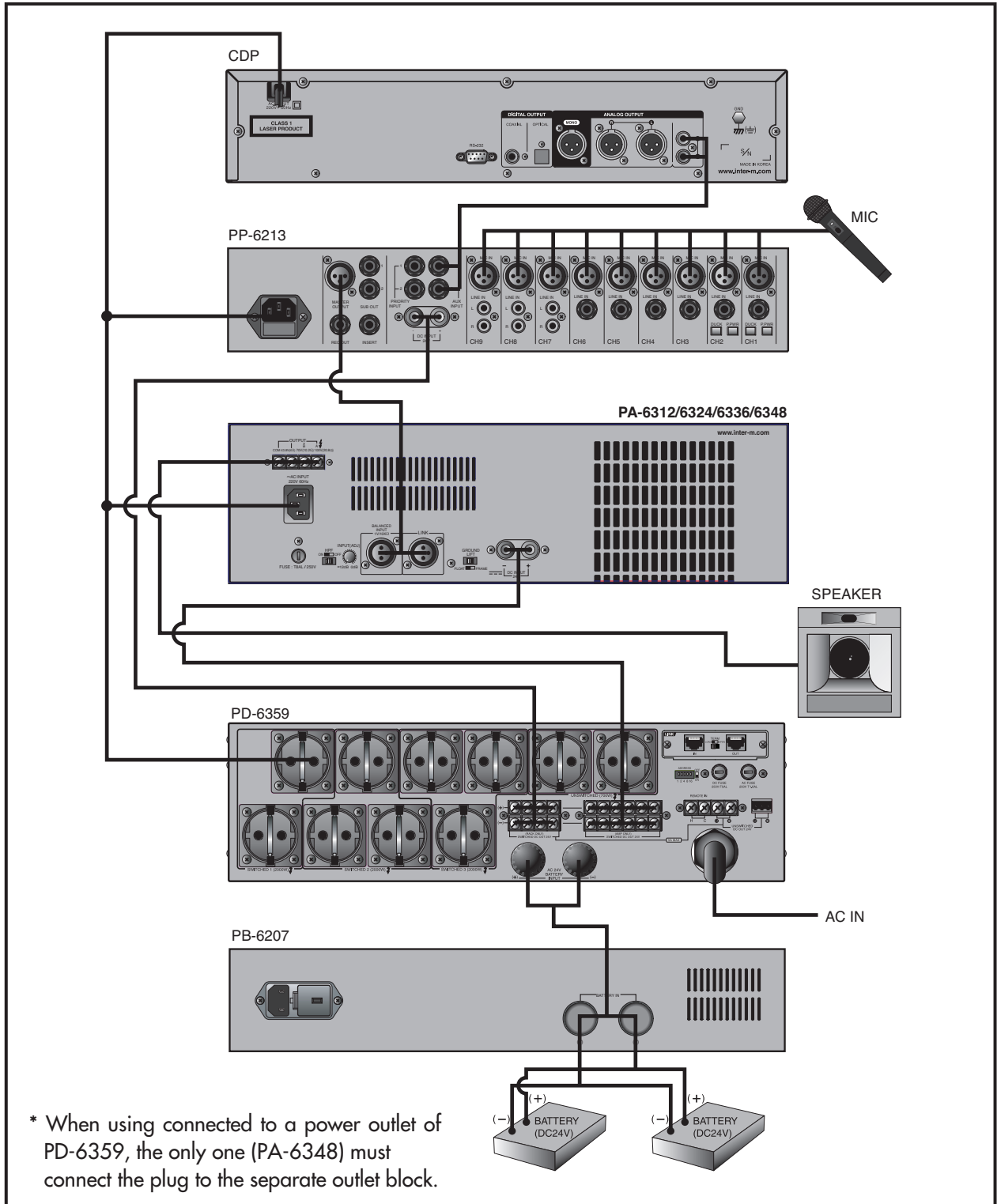

Block Diagram

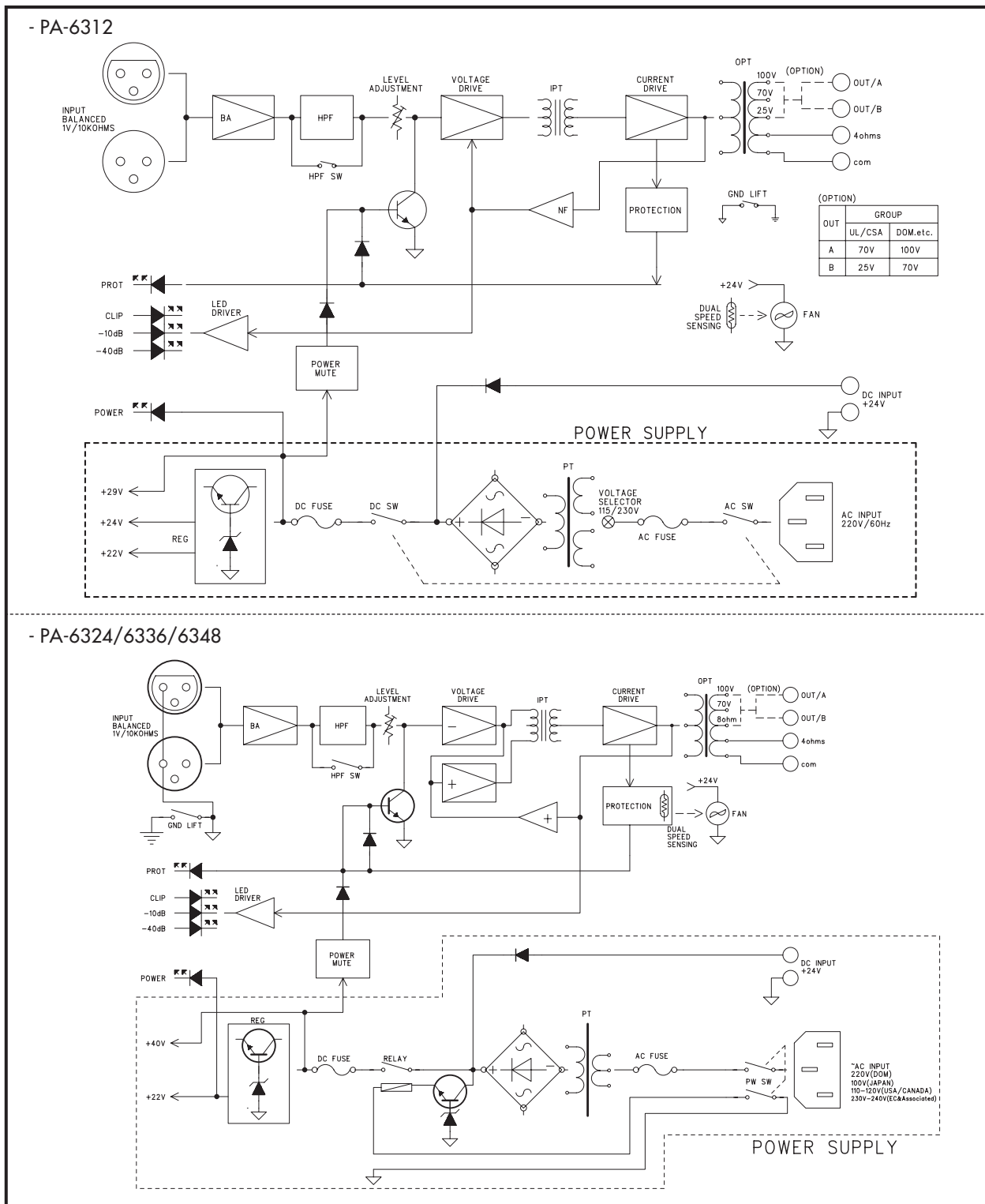

Specifications

	PA-6312	PA-6324	PA-6336	PA-6348
Rated Output Power (THD 5%, 1kHz)	120W	240W	360W	480W
Frequency Response (+1/-3dB)	70Hz-18kHz			
T.H.D	Less than 1%			Less than 5%
High Pass Filter	400Hz, -3dB			
Gain Control	0dB ~ -12dB			
S/N	Better than 95dB			Better than 90dB
Input Sensitivity/Impedance	1V/10k Ω Balanced			
Output Voltage/Impedance	4 Ω /22V	4 Ω /31V	4 Ω /38V	4 Ω /43.8V
	41 Ω /70V	21 Ω /70V	13.6 Ω /70V	10.2 Ω /70V
	83 Ω /100V	42 Ω /100V	27.8 Ω /100V	20.8 Ω /100V
Operating Temperature	-10° C ~ +40° C/14°F~104°F			
Power Source	100-120VAC or 220-240VAC; 50/60Hz, 24VDC (Supplied AC mains transformer depends on country requirements)			
Power Consumption (1/8 power)	130W	450W	450W	600W
Weight (SET)	14kg/30.8lb	19kg/41.9lb	19kg/41.9lb	22kg/48lb
Dimensions (SET)	482(W) × 132(H) × 280(D)mm/19(W) × 5.2(H) × 11(D)in			

* Specifications and design are subject to change without notice.

※ DIMENSIONS

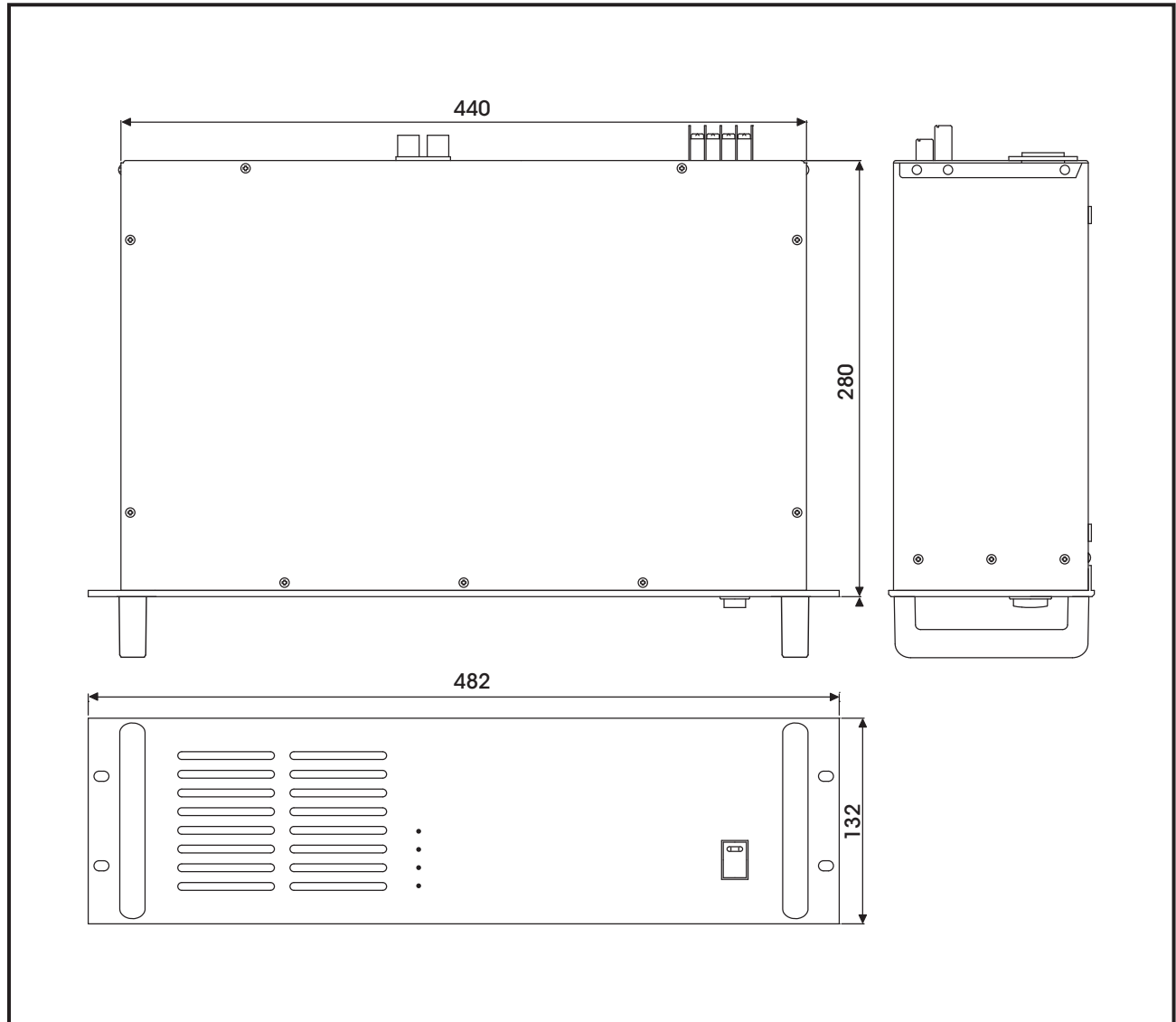

Service

Procedures

Take steps to insure the problem is not related to operator error or other products within the system. Information provided in the troubleshooting portion of this manual may help with this process. Once it is certain that the problem is related to the product contact your warranty provider as described in the warranty section of this manual.

Schematic

A Schematic is available by contacting your warranty provider.

Parts List

A Parts List is available by contacting your warranty provider.

Variations and Options

Variations

Products supplied through legitimate sources are compatible with local AC power requirements.

Options

No optional items are available for this product.

Warranty

Warranty terms and conditions vary by country and may not be the same for all products. Terms and conditions of warranty for a given product may be determined first by locating the appropriate country which the product was purchased in, then by locating the product type.

To obtain specific warranty information and available service locations contact Inter-M directly or the authorized Inter-M Distributor for your specific country or region.

PHONTECH

by ZENITEL GROUP

PHONTECH Communication Systems Power Amplifier 1670



► Power Amplifier 1670

PUBLIC ADDRESS & ALARM SYSTEM

The AMP 1670 is a high performance, high efficiency 400 watt power amplifier designed to meet the needs of the most demanding PA/GA applications. The amplifier is designed to operate from a 48VDC power supply. It is only 1U high, weighs only 6.5kg and power consumption is only 480W at rated power output. Quiescent power consumption is also very low, at less than 5W.

Inputs and Outputs

The AMP 1670 features two balanced line level inputs, normal and priority. The AMP 1670 provides one 100 volt line output.

Controls and Metering

The front panel consists of a recessed power switch and recessed screwdriver adjustable controls for adjustment of the optional line surveillance board. The front panel of the AMP 1670 includes a LED dB meter, Power status led, amplifier protection and line surveillance status leds.

Protection

The AMP 1670 features a slow start function as well as overload and overdrive protection. Should the amplifier be overdriven, a current limiter will protect the unit, and in a worst case scenario the amplifier will shut down until the problem is resolved. Once the problem is fixed (shorted speaker line, or overdriven input), the amplifier will automatically reset and continue operation. The AMP 1670 features internal heatzink with fan cooling. The fan will start to turn if the operating temperature exceeds 40°C, and turn at full speed at 50°C. The amplifier will protect itself at 90°C and resume operation when the temperature has dropped to 70°C. The fan exhaust is in the rear of the amplifier, and the air inlet is in the front.

SPECIFICATION

Power Output:	400 Watts RMS into 100 Volt line
Maximum Load:	25 Ohms @ 100V
Frequency Resp.:	200Hz - 15kHz (ffl 3dB) into 100V
THD:	Less than 0.5% @ 1kHz
Distortion at Max Power:	Less than 1%
Signal To Noise Ratio:	-90dB
Input Sensitivity:	0.775Vrms (0dBu)
Input Impedance:	22K Ohms
Output:	100 Volts line
Metering/Indicators Amp Status:	LED output meter Power supply LED Protection LED
Power Source:	48VDC nominal (40-64V)
Power Consumption:	480 Watts (max)
Power Consumption quiescent:	5W
Dimensions:	44mm H x 483mm W x 320mm D
Weight:	6,5 kg



Other Features:

- Zone selection: It is possible to disconnect the load and mute the amplifier to provide zone selection.
- It is possible to install the optional PHONTECH Line Surveillance board to monitor both amplifier operation and line condition.
- The amplifier can be muted via a mute input.
- It is possible to choose which line input is to operational.
- Hot pluggable for fast and easy field replacement.
- Protection Internal Cooling Fan with temperature sensor
- Current Limiter with auto protect and auto reset
Controls: Front Panel Power Switch, Recessed front panel

Agent/Distributor:

zenitel

Zenitel AS reserves the right to change the design and/or specifications at any time without prior notice. Reservations are also taken towards any general errors that may occur.

v.A

www.phontech.net

Zenitel Norway AS
Bromsveien 17
3183 Horten
P.O. Box 1068 Bekkajordet
3194 Horten
Norway

Tel. +47 40 00 27 00
Fax. +47 33 03 16 61
phontech@zenitel.com